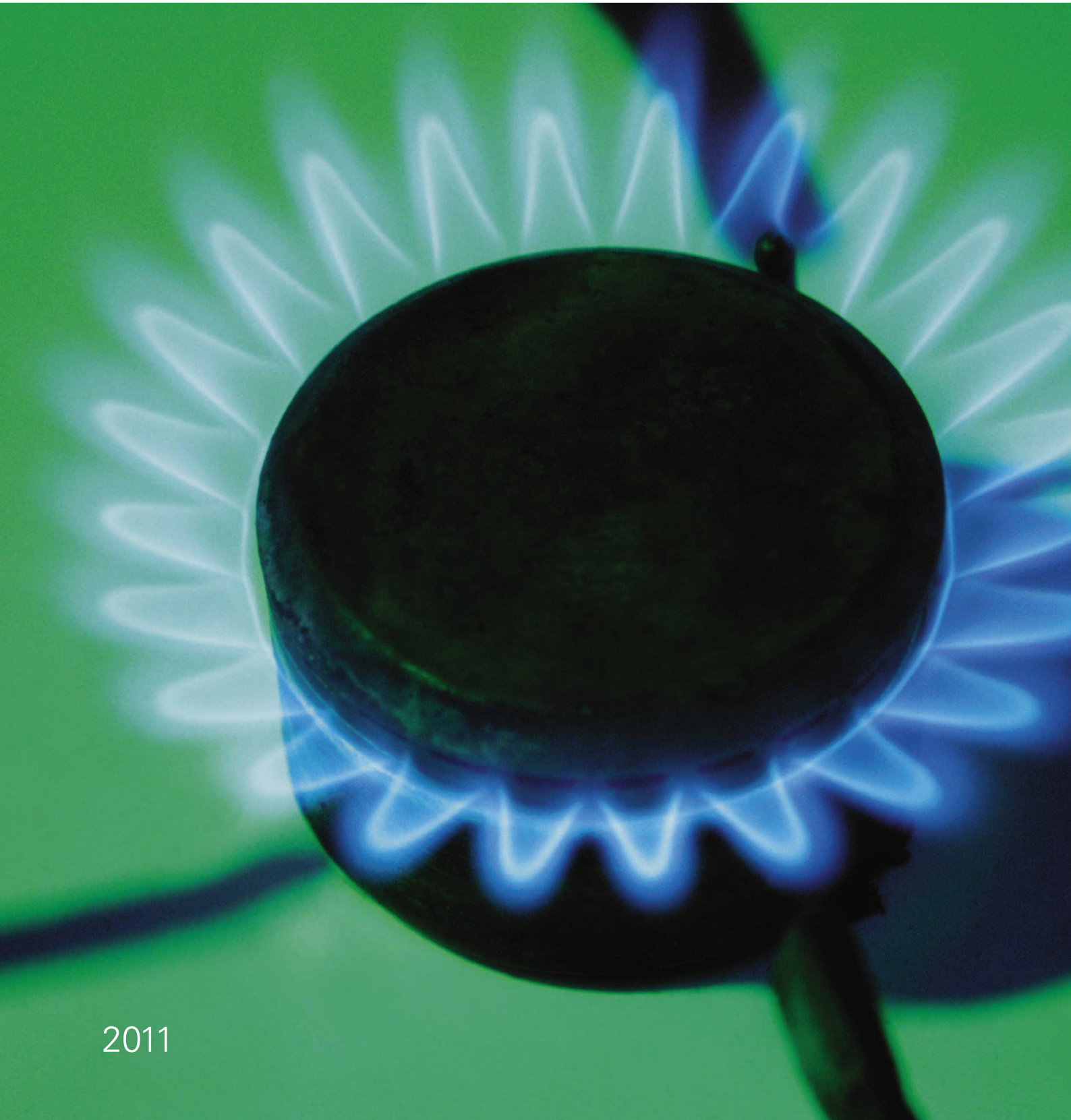




## Guidebook to Gas Interchangeability and Gas Quality



2011





# Guidebook to Gas Interchangeability and Gas Quality

2011

## **Disclaimer:**

The information contained in this document does not necessarily reflect the opinion or the position of BP or the IGU. BP or the IGU do not guarantee the accuracy of the data included in this document, nor do they accept responsibility for any use made thereof.

## **Acknowledgement:**

This Guidebook is published by BP in association with the IGU. BP wishes to acknowledge the contribution of GL Industrial Services in the preparation of this Guidebook. In addition, a number of people within BP have assisted with the preparation of this Guidebook including Stephen Hull, Karen Wood, Ieda Gomes, Ben Ho, Steve Kerr, Jonathan Kershaw, Salli Cavanagh and Doug Wood.



## BP foreword

LNG has been steadily increasing its share of the global gas trade. There are now LNG producers and importers across the globe as LNG has become synonymous with energy diversity and security of supply. However, in order for LNG to be a truly globally traded commodity, quality and interchangeability matters need to become fully understood and resolved. Furthermore, buyers, sellers, and regulators need to take into account health and safety, and economic imperatives.

At BP we have developed several in-house models to predict and resolve quality and interchangeability issues, and more recently we commissioned a comprehensive "Guidebook to Gas Interchangeability and Gas Quality".

It is with great pleasure that we now launch the external version of the Guidebook in association with the International Gas Union (IGU). BP is an active member of the IGU and during the 2006 - 2009 Triennium BP's experts led a sub-group on LNG quality, working with worldwide industry specialists. For BP, partnership is an essential part of our business and partnering with the IGU to launch the Guidebook is a natural and welcome extension of this important work.

With the launch of the Guidebook we hope to enhance the understanding of critical quality and interchangeability issues, and foster increased activity across the global gas industry.

**Alan Haywood**

President Downstream Gas, BP



## IGU foreword

We congratulate BP in coming out with the 2011 update of this fine publication, which is an excellent and unique contribution to the global gas fraternity.

The production of such a guidebook could not have been more timely considering that natural gas is fast becoming a global commodity resulting from increased cross-border interconnections and the globalisation of LNG trade coupled with increasing penetration of unconventional gas into the gas markets. Greater harmonisation of worldwide understanding of gas interchangeability and gas quality will not only help to promote greater use of natural gas but will enhance safety and reliability of gas infrastructure and assets throughout the gas value chain. This guidebook is a useful source of information on the subject and will act as an excellent reference guide for different stakeholders involved in the different parts of the natural gas supply chain.

**Datuk (Dr) Abdul Rahim Hashim**  
President, IGU

IGU is an international organisation with the objective to promote the technical and economic progress of the gas industry worldwide. As an associate member of IGU, BP has been actively involved in the IGU Executive Committee and various other initiatives aimed at addressing key issues and challenges facing the global gas industry. IGU is proud to work with BP and welcomes other members and industry players to similarly contribute towards such efforts, including undertaking joint publication with IGU of relevant topics that will contribute to the enhancement of knowledge for the benefit of the industry.

**Torstein Indrebø**  
Secretary General, IGU



## Preface

Rising worldwide demand and declining indigenous supply has resulted in a rapid increase in international trading of natural gas to ensure security of supply. This has brought focus on the specification of gas quality from different sources. Gas interchangeability is important to maintain the safety and reliability of pipeline networks and downstream equipment.

With the growth in natural gas trading via pipeline interconnectors and LNG shipping, there is a current willingness to harmonise worldwide understanding of gas interchangeability through common definitions, specifications and contract conditions.

# The Issue in Brief

## The three frequently asked questions

- What is interchangeability?

A common definition of interchangeability is:

*The ability to substitute one gaseous fuel for another in a combustion application without materially changing the operational performance of the application (its safety, efficiency or emissions).*

- Why is interchangeability important?

Although covered by a generic term, 'natural gas' varies in composition, and therefore quality, depending on its source worldwide. All gas-fired equipment is designed to operate within a particular range of gas specification. If gases outside this range are combusted, this can lead to a range of problems from poor quality combustion through to equipment damage and ultimately dangerous operation.

- What are the parameters governing gas interchangeability?

"Are gases with the same calorific/heating value all interchangeable?" The answer is: "not necessarily." Gas interchangeability relates to more than just a parameter for calorific/heating value. It is governed by gas quality, a function of gas composition. Other factors that affect the interchangeability of a gas include its specific gravity, combustion indices, etc. An in-depth description of how interchangeability and gas quality are related can be found in Chapter 2 of this guide.

## Interchangeability standards in the worldwide gas markets

- Gas specifications vary for different countries and are set to suit the local gas quality and equipment. Many international markets do not yet have clear or nationally set gas quality specifications (this issue is dealt with in-depth in Chapter 2 and Chapter 3).
- As markets for natural gas have opened up, there are lead regions which have developed, or are developing, gas network entry requirements to facilitate trading. These regions include Europe, North America and the Far East where LNG trade is increasing. For example, gas quality in the UK is governed by the Gas Safety (Management) Regulations 1996 or GS(M)R.
- The driving force for establishing rules of interchangeability focuses on safety and operability for domestic, commercial and industrial applications. Harmonisation of gas specifications enables end-users to be confident in purchasing equipment.
- Much of the LNG that is now being traded internationally has quality specifications which are outside the range allowed in established networks. This gives rise to a number of issues along the gas chain, which will be covered in greater depth in Chapter 1.

### Issues with off-specification natural gas

### Commercial/financial impacts

#### At the upstream production

Onshore facilities could be needed to treat or condition the gas for network entry.

Could mitigate against trading certain gas into particular markets. Additional CAPEX for gas quality adjustment.

#### Within the transmission network

Blending of off-specification gases at entry may be possible, with

- availability of blending gas
- understanding of network operation and regulations.

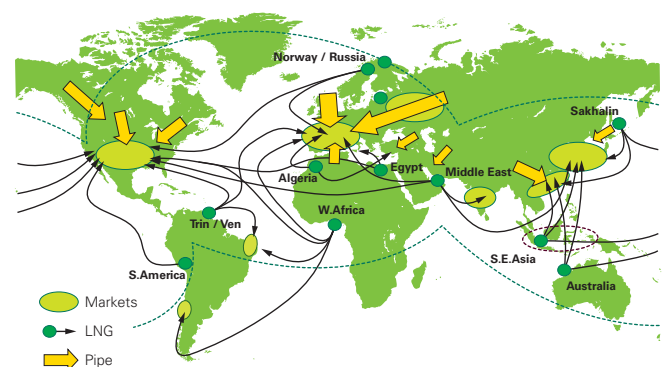
Different levels of higher hydrocarbons and moisture in the network may lead to problems with network operations. Unexpected maintenance costs.

#### Downstream /utilisation

Possible problems with domestic and industrial combustion equipment

- inefficient/unstable combustion
- incomplete combustion: Fatalities by production of toxic emissions
- irreparable damage to gas turbine system.

Direct losses in life, efficiency and production costs.



### How will this guidebook help a company?

A company may be a producer, marketer and trader of LNG worldwide. The background, experience and knowledge of users/ readers of the Guidebook will therefore differ widely in terms of understanding operational process, downstream combustion equipment and commercial issues.

The Guidebook is seen as providing educational benefits to the different users to support the adoption of a consistent strategy and customer approach.

- **To upstream process engineers** – Reasons why gas quality limits are adopted and the impact of gas quality variations on emissions and performance of gas-fired downstream equipment.
- **To marketers and traders** – The ability to review the reasons and options for modifying gas quality at network entry points to meet regulations and customer demands.
- **To all users, including those in Regulatory Affairs** – Appreciate the different gas specifications and legislation currently in force across the world and be able to compare the parameters and limits being set for gas interchangeability.

The result of this increased knowledge should improve communications regarding gas quality specifications between the company and its customers. These customers, across the gas value chain, may include:

- **Gas traders (shippers)** buying and selling gas across national networks.
- **Gas transmission companies** transporting gas through high pressure pipelines to distribution networks or large industrial users.
- **City gas distribution companies** providing low pressure gas to premises.
- **Gas suppliers** providing energy services to end-users
- **End-users** as gas consumers.

The Guidebook collates data from a variety of sources regarding the latest international views on gas interchangeability and gas quality specifications. It is a comprehensive source of information on the subject, discussing the issues and the implications particularly in relation to LNG production and marketing. It is intended to be a useful reference document for all personnel working across design, operations, marketing and trading of natural gas.

The Guidebook is structured to enable each chapter to be presented as an individual standalone topic.

Each chapter of the Guidebook begins with an overview and then builds technical information around a series of issues and solutions. In some cases the technical detail has been placed in an appendix in order to maintain the flow of the main text but the more complex data is still retained and available if required for further reference.

Throughout the Guidebook use will be made of real-world Case Studies highlighted in light green which illustrate how gas quality and interchangeability have impacted on past and existing gas operations, and how solutions have been found to the problems and challenges which have occurred across the gas industry world-wide.







## **Chapter 1** **Issues Overview**

This will present an overview of how gas quality can impact on operations across the gas chain, and introduce some of the interchangeability parameters and combustion concepts that will be covered in detail in the later chapters.



## **Chapter 5** **Future Markets and Deregulation**

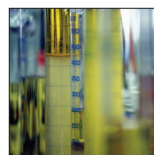
This will examine the historical growth and future trade in LNG, and go on to show whether gas quality specifications already exist in key markets, or whether they still need to be developed.

It will also look at how established markets are developing, being driven by market liberalisation and security of supply issues, and what the implications are for cross-border trading in natural gas.



## **Chapter 2** **Interchangeability and Combustion Parameters**

This will introduce the subject of interchangeability and gas quality specifications and show how these are measured. It will also highlight the differences between UK, European and US definitions of the parameters.



## **Chapter 6** **Impact on End-users**

This chapter will look at the implications of the growing international demand for LNG, both from an upstream angle, where there may be requirement for flexibility in processing, and from a downstream angle where safety and efficient operation of appliances may be an issue.

The downstream impact will cover examples from gas turbines with large gas load for power generation, also large industrial processes and down in scale to domestic gas appliances.



## **Chapter 3** **International Standards and Country Regulations**

This will compare the regulations and standards used for measuring gas quality and interchangeability internationally, and will also look at the attempts being made to harmonise gas quality.



## **Chapter 7** **Options to Manage Gas and LNG Interchangeability**

This will examine the options for treating LNG at import point to attain qualities which allow it to be transported in networks. Indications of costs and benefits of upstream conversion versus downstream conversion will be given.



## **Chapter 4** **LNG Production, Supply and Lifecycle**

This chapter will take an in depth look at the way LNG is produced and supplied, and also show how this impacts on different compositions and gas qualities from different sources.

This will then examine issues related to the transport and handling of LNG, including loss of boil-off gas, ageing, stratification and rollover, and custody transfer and energy accounting.



## **Chapter 8** **Conclusions and Strategic Decisions**

Pulling together the various strands of the guidebook, this will attempt to show how the end-user can make best use of the information provided. It will highlight factors which need to be considered in any strategic decision making process regarding gas interchangeability and natural gas trading.



## Chapter 1

### Issues Overview

All gas-fired equipment is designed and built for a particular gas specification. This will include a range of gas qualities within which the appliance will function correctly. If gases outside this range are combusted, this can lead to a range of problems from poor quality combustion through to equipment damage and ultimately dangerous operation.

This Chapter will present an overview of how gas quality can impact on operations across the gas chain, and introduce some of the interchangeability parameters and combustion concepts that will be covered in detail in the later chapters.

## 1.1 The Importance of Interchangeability

- If the consequences of interchangeability are not understood, they can result in inefficiencies, poor network and equipment performance. The affected combustion equipment can also cause unsafe and potentially fatal operations. This section gives the background to the gas interchangeability concept and its importance to cross-border gas trading.

## 1.2 What are Gas Quality and Interchangeability?

- Interchangeability depends on gas quality, but sometimes the two are confused. This section describes and attempts to define the two.

As a subset of the gas quality specification, the interchangeability parameters are introduced to ensure a substitute gas would continue to deliver satisfactory performance in the safety, efficiency and emissions aspects.

## 1.3 Interchangeability in the Gas Chain

- The requirement for a particular gas quality specification in a particular market leads to a range of consequences; from upstream processing, through network transportation into the realm of combustion. Can an imported gas be introduced into a network without further processing? What happens if it is out of specification when it reaches users? This section provides a brief introduction to issues related to gas interchangeability across the gas chain. More details are included in later chapters.

### 1.3.1 Upstream Issues

- This covers briefly the treatment processes for off-specification gases and the gas quality issues related to liquefied natural gas (LNG) supply.

### 1.3.2 Midstream Issues

- This explores the issues with and benefits of gas quality adjustment within the network, known as gas mixing or blending. Possible problems due to the introduction of the relatively dry regasified LNG into older distribution networks are also looked at here.

### 1.3.3 Downstream Issues

- The development of new generation burners and their compatibilities with a range of gas qualities are discussed here.

## 1.1 The Importance of Interchangeability

---

**Variations in gas quality could cause problems in (i) meeting operational safety and performance concerns; (ii) ensuring system integrity and operability for gas transportation and (iii) meeting the energy billing requirements. If the quality of the imported gas does not meet pipeline specification, there are options to either:**

- **adjust the gas quality at the point of production;**
  - **adjust the gas quality at entry points to meet existing limits; or**
  - **consider widening the gas specification limits, taking into account the impact that might have on the operation of downstream gas-fired equipment.**
- 

### 1.1.1 The Issues

Gas interchangeability is not a new concept. In the 1960-70s a considerable amount of work was completed, particularly in the USA and Europe. This work was triggered by the need for step changes from a manufactured (town) gas to natural gas. However, interchangeability has come increasingly to the fore over the last ten years due to the increase in cross-border transport of gas, the depletion of mature fields and their replacement by production in different geographical areas, and the rapidly developing world market in liquefied natural gas (LNG).

The issue is therefore how to ensure security of gas supply at reasonable cost, knowing that gas quality parameters of much imported gas may be at the extremes of, or outside, existing gas-specification limits.

Within the last year, there has been increasing activity in sharing knowledge and awareness of gas quality and interchangeability because it is being raised as an issue across the Far East, particularly Japan, China, and Korea, where LNG imports are significant, and in India, where the impact of gas quality fluctuations on natural gas vehicle operations is becoming important. This has also happened in Europe, where LNG imports start to materially compete against traditional gas supply, and in USA, where LNG imports have been projected to provide a fair share of the overall gas supply by EIA.

The most common measure of interchangeability worldwide is the Wobbe Index (of which, more later). For example, re-gasified LNG typically has higher Wobbe Index than pipeline gases, and as such often needs to be treated prior to entry into transmission systems.

A consistent, internationally recognised way of interpreting gas interchangeability is still to be developed. Different countries, and even different regions within the same country, use a variety of dissimilar parameters and limits of acceptable performance to assess the impact of variable gas quality on gas supply and consumer operations.

The issues that can arise from changes in gas quality include:

#### **Meeting the operational safety and performance concerns**

- Efficiency and safety of commercial and domestic appliances, whether through extreme heating values of gases or as a result of quality correction through ballasting of gas with nitrogen or other inert gases.
- Heating value, including transient or rapid changes, seriously impacting power generators and turbines.
- Effects on product quality in industrial processes where combustion is critical or gas is used as a feedstock.
- Methane number and inert content affecting natural gas engine performance.

#### **Ensuring the system integrity and operability for gas transportation**

- Potential non-compliance with natural gas transportation regulations since regulations often differ across State and national boundaries.
- Effects on seals in the distribution system due to the relatively dry nature of re-gasified LNG.

#### **Meeting the energy billing requirements**

- Difficulty in measurement and control of variable heating value.

### 1.1.2 The Applications

In pursuit of increased equipment efficiency and lower emissions, we have seen development of a new generation of gas-fired appliances, with pre-mixed and staged combustion. These may not adjust readily to wide variations in gas quality and may not be appropriately represented by existing interchangeability parameters, which were derived empirically using appliances popular more than 30 years ago.

Domestic and commercial appliances are usually tuned to accept a relatively small range of Wobbe Index values.

Industrial combustion applications may similarly be sensitive to changes in gas quality. For example, gas turbines are typically tuned to work within  $\pm 5\%$  of the Wobbe Index set-point. Outside of this range, non-optimised combustion can lead to anything from inefficiencies and instabilities through to dangerous levels of carbon monoxide (CO) production. Where manufacturing processes (e.g. glass and ceramic production) rely on heat input and gas quality, product quality can be seriously affected, particularly where heating is controlled by volume of gas burned rather than energy throughput control.

### 1.2.1 Gas Quality

**Gas quality specification is based on gas composition. Changes in gas quality can be used to ensure better gas industry operational efficiencies, but quality standards must take into account the impact on end-use gas-fired equipment performance. Some common gas quality parameters include water and hydrocarbon dewpoints (below which the gas will begin to condense), total sulphur, inert concentration and the Wobbe Index.**

Gas quality has two major technical aspects:

- The “pipeline specification” in which stringent specifications for water and hydrocarbon dewpoint are stated along with limits for contaminants such as sulphur. The objective here is to ensure pipeline material integrity for reliable gas transportation purpose.
- The “interchangeability specification” which may include parameters of calorific value and relative density which are specified to ensure satisfactory performance of end-use equipment (safety, performance and emissions).

The specification for gas quality can be national or area specific. For example:

- In the UK, gas entering the national transmission system (NTS) is governed by the standardised Gas Safety (Management) Regulations 1996 or GS(M)R.
- In the USA, interchangeability has remained a regional issue and quality of the delivered gas is managed by individual interstates pipeline companies.

The rise in gas trading across international borders through new pipeline interconnectors and LNG shipping brings with it concerns for the variability of gas quality delivered from different sources. A high-level comparison of the gas composition and quality between a typical natural gas and LNG is presented in Table 1.1.

**Table 1.1** – Gas Composition of a Typical Natural Gas and LNG.

	Natural Gas	LNG
Methane	88.860%	91.1%
Ethane	4.240%	4.3%
Propane	1.140%	3.0%
Butane	0.424%	1.4%
Pentane	0.126%	0
Hexane	0.081%	0
Heptane	0.024%	0
Octane	0.003%	0
Nitrogen	4.006%	0.2%
Carbon Dioxide	1.096%	0
Water	0.01%	0
Hydrocarbon Dewpoint	-10.61°C	-27.8°C
Wobbe Index, MJ/m <sup>3</sup>	48.53	52.84

### 1.2.2 Gas Interchangeability

**Gas interchangeability ensures that any gas-fired equipment using a substitute gas should continue to meet the performance standards to which it was originally approved. It is determined by the quality of the gas.**

Gas interchangeability is a subset of the gas quality specification ensuring that gas supplied to domestic users will combust safely and efficiently.

The most common, but not universal, measure of interchangeability, the Wobbe Index is represented by the formula below. The Wobbe Index is used to compare the rate of combustion energy output of different composition fuel gases in combustion equipment. For two fuels with identical Wobbe Indices, the energy output will be the same for given pressure and valve settings.

Wobbe Index or Wobbe Number =

$$\text{Higher Heating Value of the gas} / \sqrt{\text{Relative Density}}$$

Different interchangeability measures have been specified by countries worldwide mainly arising from historical evolution of downstream equipment populations, and characteristics of locally sourced gas. For instance,

- In the Continental Europe, limitations on Wobbe Index and inert gases are considered to be sufficient for wholesale gas.
- The UK looked further into parameters related to appliance non-optimum performance such as the Lift Index, Incomplete Combustion Factor and Soot Index.

These parameters, along with the Wobbe Index, will be explained further in Chapter 2 where an in-depth explanation of interchangeability will be given.

## 1.3 Interchangeability in the Gas Chain

### 1.3.1 Upstream Issues

**Depending on the gas composition, a “derichment” (typically for LNG) or “enrichment” (for lean gas with a lower Wobbe Index) process would be required to meet the local specifications.**

**LNG “boils-off” during storage and transportation due to heat that enters the cryogenic tank, changing the LNG quality with time. Therefore, careful planning for trading and importation of LNG is required based on the treatment facilities (derichment or enrichment) available at the import terminal. When mixing of LNG is carried out, safety management is crucial to avoid rapid release of LNG vapour (known as LNG boil-off gas).**

Natural gas produced offshore, processed and sold to markets has to meet the gas quality specifications developed by local regulatory bodies. In most countries, it is the responsibility of the gas importers or producers to ensure that the gas is conditioned to a consistent gas quality prior to injecting into the pipeline, as stated in their contract with the gas transporter.

Depending on the gas composition, a “derichment” (reducing heating value) or “enrichment” process would be required to meet the local specifications (Table 1.2). In some circumstances, gas is landed at shore from a variety of fields or at a number of sub-terminals operated by different producers. These supplies are typically processed separately to the required specification, but in some cases offshore or onshore blending has been permitted to reduce the processing requirement.

LNG, sourced from the Middle East and Far East, comprises methane dominantly (higher hydrocarbon concentration is low) and therefore, has a higher Wobbe Index than typical natural gases from Europe or North America. Derichment is generally required for local use.

**Table 1.2 – Derichment and Enrichment Processes.**

#### Derichment Processes

- Blending with lower Wobbe Index gas.
- Ballasting – with nitrogen, carbon dioxide, air or hydrogen.
- Removal of natural gas liquids (NGL).

#### Enrichment Processes

- Blending with higher Wobbe Index gas.
- Carbon dioxide or nitrogen removal.
- Liquefied petroleum gas (LPG) injection.

LNG poses different upstream gas quality issues in terms of trading and contractual requirements. During LNG storage and transportation, a small percentage of LNG will “boil-off” due to the traces of heat entering the cryogenic storage tank. Boil-off gas is comprised mainly of the more volatile components like methane and nitrogen. This preferential evaporation therefore results in LNG quality which is variable with transport and storage time. This is known as LNG ageing or weathering (more detail in Chapter 4).

Most LNG used to be traded on an ex-ship basis. However, with liberalisation of the LNG industry and the increasing roles of international oil companies in LNG transportation and importation, the free-on-board (FOB) LNG contracts have become increasingly popular. This transfers the responsibility of LNG shipping from seller to the buyer at the port of shipment. LNG is sold based on its specification at the port of shipment.

The flexibility of a LNG terminal operator to accept a spot LNG cargo is decided by the ballasting or treatment facilities available at the terminal if the local gas specifications are restrictive. On top of this, mixing different qualities of LNG “in-tank” poses a risk of stratification where layers of LNG with different densities can be formed. This can potentially lead to a rapid release of LNG vapour and over-pressurisation of the tank if spontaneous mixing of these layers happens (known as LNG rollover).

### 1.3.2 Midstream Issues

**Gas mixing within the network may be possible provided that continuous gas supplies of appropriate quality are available.**

**Gas mixing within the network could be used for:**

- **Separate gas supplies, of which one or more may be out of specification.**
- **Out-of-specification LNG boil-off gas with pipeline gas.**
- **Export flows from different LNG tanks to minimise the propane enrichment.**
- **LNG send-out alongside pipeline gas.**

**In older gas networks, cast iron pipes may be jointed with lead and yarn that needs to be kept swollen to maintain the seal. The introduction of relatively dry gas including regasified LNG could be implicated in deterioration of the seal, resulting in leaks and compromising safety.**

#### Gas mixing in networks

For most network operators it is a requirement that gas entering the network is fully compliant with the relevant safety specification. This reflects the limitations on the operation or configuration of a gas network for gas mixing (also known as gas blending or co-mingling).

However in some circumstances gas mixing in networks is possible and may enable a rich gas to be diluted or a lean gas to be enriched to meet a supply specification. The following are examples where co-mingling is beneficial:

1. Mixing of separate gas supplies, of which one or more may be out of supply specification, within an onshore reception terminal is possible where the supplies of each gas are continuous and reliable.
2. All gas entering the UK National Transmission System, (NTS) must be compliant with the GS(M)R unless exempted. For example National Grid have agreed with the UK Health & Safety Executive exemptions for specific sections of the network to facilitate co-mingling within that section.

For example, gas from the Barrow terminal, situated on the west coast of England is very lean with a Wobbe Index below the GS(M)R limit. By mixing the Barrow gas with the richer gas flowing through the networks from the North Sea fields within an underground loop of pipeline specifically constructed for this purpose, the Wobbe Index is raised to an acceptable level.

3. The normal operation of LNG sites will generate a volume of boil-off gas from the storage tanks that, whilst high in methane content may contain sufficient levels of nitrogen to render the gas too lean for direct supply to customers. Historically in the UK boil-off gas (from LNG storage sites), was allowed to enter the gas network

with the knowledge that it would co-mingle with pipeline gas and meet the supply specification before it reached the end user. More recently network operators have required the boil-off gas to be GS(M)R compliant at the point of entry to avoid any possible infringement of safety regulations.

4. Gas supply companies in Japan have traditionally supplied natural gas, exclusively regasified LNG, to end users at a fixed calorific value. This gas can sometimes require enrichment by propane addition as Japan requires richer gas than most world markets. Quality can be achieved by careful management (mixing) of the export from different LNG storage tanks of different composition, minimising the level of propane enrichment.
5. In the USA, the safe introduction of an LNG supply into a network transporting indigenous natural gas has been supported by studies of zones of influence of co-mingled supplies through connected systems.

As countries source gas from increasingly diverse supplies, the ability to mix gas within the network will extend the range of gases that can be safely accepted. Current interest is focussed on identifying cost-effective methods of accepting LNG into natural gas networks. However, biogas, landfill gas, mines gas and possibly even hydrogen may need to be accommodated within the existing networks to meet future gas demand.

With the advent of the European Union gas directives relating to open access of natural gas pipeline networks, the current European position is stated as "... taking into account the necessary quality requirements, biogas and gas from biomass or other types of gas are granted non-discriminatory access to the gas-system, provided such access is permanently compatible with the relevant technical rules and safety standards. These rules and standards should ensure, that these gases can technically and safely be delivered into, and transported through, the natural gas system and should also address the chemical characteristics of these gases..."

#### Dry joints in distribution systems

In older gas networks, especially those remaining in the USA, cast iron pipes may be jointed with lead and yarn that needs to be kept swollen to maintain the seal. This can be achieved either by the gas that is transported, or alternatively by injecting conditioners into the gas flow.

The introduction of relatively dry gas, such as regasified LNG, into a network may be implicated in the deterioration of seals located within mechanical couplings that connect sections of distribution mains and service lines resulting in leaks and compromised safety. There is anecdotal evidence for this when a city was converted from town gas to natural gas supply. Gas conditioning, by sealant injection is a consideration for new LNG markets that contain old distribution networks.

### 1.3.3 Downstream Issues

Newer gas-fired equipment with pre-mixed and staged combustion for increased equipment efficiency and lower emissions is usually tuned to accept a narrow range of Wobbe Index values (about  $\pm 5\%$ ). This equipment includes gas turbines and some domestic burners.

For the end-user, gas quality variations are primarily reflected during combustion although there may be additional issues if the gas is used as a bulk chemical feedstock. End use or downstream combustion applications cover various technologies over a range of scales from small cooker hob burners, through engines and commercial hot water systems, to large process heaters and gas turbine combustors.



Domestic Hob



Industrial Process heater

For combustion, the variation in gas quality or composition should not result in a change in operation that renders the process unsafe or inoperable. However, there are potential changes to emissions, process efficiency or product quality.

Variation in emissions with fuel quality is not restricted to natural gas fuels. It is well known that different liquid fuels can give rise to different emissions (as in vehicle engines) and, different coals can give rise to substantial changes in performance (as in large utility boilers).

All natural gas fuelled combustion systems are developed and optimised for a specific gas quality. Interestingly not all burners respond the same way to changes in gas quality. Most burner development and optimisation work focuses on improving efficiency and lowering emissions.

For **gas turbine combustors** this has resulted in a change from diffusion flames (no premixed air-gas) to lean premix. This decreases the emissions but requires significantly more complex control systems. The premixed flames can give rise to combustion instability and issues like flash-back (Figure 1.1), or noise and resonance that may result in vibration-induced damage to the burner or combustor housing. Significant effort by gas turbine engineers has improved the stability but it is typically optimised for a narrow range of gas quality. The solutions to enable gas turbines to respond to rapid changes in gas quality are in monitoring and control of the gas supply. These are discussed in more detail in Chapter 6.

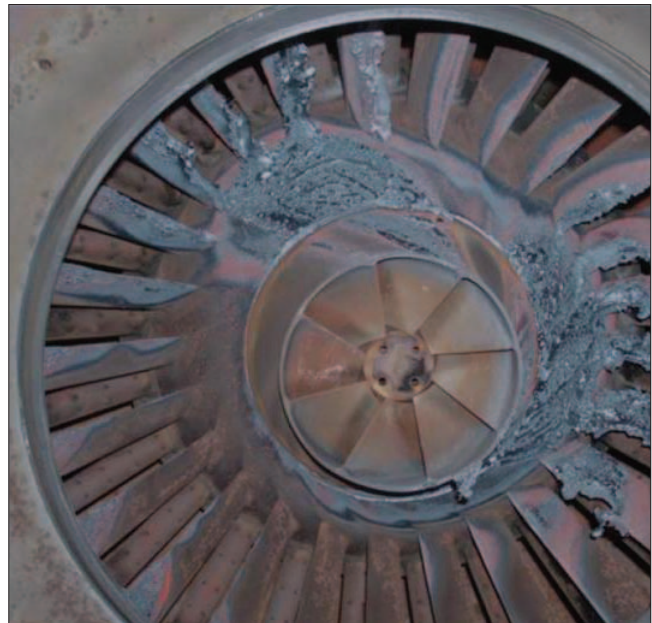


Figure 1.1 – Gas turbine – Damage from Flashback.  
(Reproduced with permission of E.ON)



In industry and commerce, natural gas is often supplied to rather **unsophisticated burner and furnace systems**. These tend to be able to accommodate rather large changes in gas quality but some industrial processes require highly controlled environments or close control of temperatures (both steady and controlled temperature as in some heat treatment applications).

### Case Study 1.1 Gas turbine – Impact on Performance

In 2005 in California, a failure of a hydrocarbon liquids removal plant resulted in a significant increase in the heat content and Wobbe Index of natural gas within the network. The failure resulted in a very rapid increase over a period of about three hours. This higher level (approx. 1,070 btu/scf) was maintained for nearly three days before the fault was corrected and gas quality returned to the more traditional level (about 1,025 btu/scf). Four combined cycle power plant had to operate with the higher Wobbe Index gas.

The gas turbine combustors and exhaust gas clean-up in the power plant were all relatively advanced systems. Most of the power plant used established Dry Low-NOx (DLN) burners and the majority also had Selective Catalytic Reduction (SCR) catalysts to lower the emission of oxides of nitrogen (NOx) further and comply with strict Californian legislation. The power plant all managed to maintain operation and output requirements were met. However, the NOx produced by the combustors increased. This was identified by the increased use of ammonia in the SCR to meet the legislated emission limits. Clearly the higher Wobbe Index gas resulted in higher operating costs for the electricity generating stations.

A more detailed look at gas turbines will be found in Chapter 6.

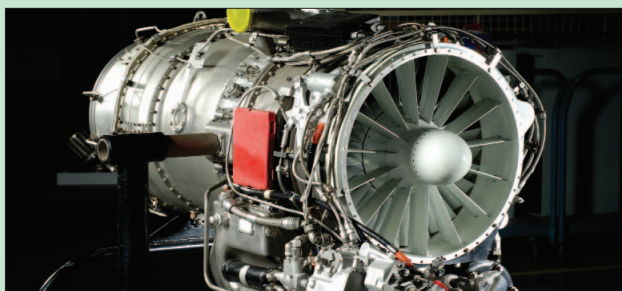


Figure 1.2 – A gas turbine.

Reference: William Walters, "Natural Gas Quality: Power Turbine Performance during Heat Content Surge" California Energy Commission, Compressed Natural Gas Workshop, August 2005.

**Domestic appliance burners** are still relatively simple in their design especially for cookers and fires. There has been a noticeable change towards premixed burners for boilers where fans are employed to ensure good mixing of the fuel with the combustion air and discharge the combustion products through the flue. The premixed nature of the burner results in a narrower operating tolerance with regard to several parameters including gas quality (also wind speed, atmospheric pressure, air temperature and others).

Although changes in gas quality can result in non-optimum performance of combustion devices, there are developments to improve the overall flexibility and control. These developments, mostly applied to industrial and commercial gas-fired equipment, include:

- Dynamic gas quality measurement with feed-forward control (suffers from response time).
- Air-to-fuel ratio control (relying on accurate measurement of fuel quality or feedback of information from the flue gas products).
- Temperature control (Higher Calorific Value gas typically results in higher process temperatures. Measurement of the temperature with feedback to the flow control.)

### Case Study 1.2 Natural Gas Quality and Natural Gas Vehicle (NGV) Performance

Fuel composition is known to affect vehicle performance. There are a number of guidelines for fuel composition for NGVs, but few standards (see Chapter 6). The demand for higher efficiency and tighter emission regulations have forced engines to narrower knock and mis-fire limits. Emissions, power and knock can be affected by higher hydrocarbon concentrations whilst methane is more difficult to remove from exhaust gases than higher hydrocarbons. The anti-knock property of a natural gas fuel can be expressed as a methane number and is analogous to the octane rating of gasoline. In addition to the anti knock quality, the operating performance of an engine on a low methane number fuel may be important. Low methane number is usually a result of the presence of higher hydrocarbons in the fuel. In addition to the methane number, the Wobbe Index is also an important parameter for gas engines, as it determines both the power and equivalence ratio, and changes that might result in poor operational and environmental performance.





## Chapter 2

### Interchangeability and Combustion Parameters

Natural gas is mainly used or burned in combustion processes but is also an important feedstock in chemicals production.

Combustion is a complex chemical and physical phenomenon. The chemical energy contained within the fuel is released producing heat and light, and the fuel is converted to more stable products. To ensure that different natural gases behave similarly in combustion systems they must have similar combustion parameters (for example Heating Value, Wobbe Index and Relative Density).

Fuel type or quality is known to have an impact on combustion operation and efficiency, and systems are optimised to use one particular fuel. If the fuel characteristics change then the system performance may deteriorate.

Interchangeability of gases is achieved if combustion is not materially changed when one natural gas is substituted for another, particularly with regard to safety, efficiency and emissions).

An analogue of this is internal combustion engines using different fuels of different octane ratings. Whilst the engines generally continue to function with a change in Octane Number, the emissions change and the power produced can vary.

This section explains some of the important combustion parameters and introduces different methods of characterising natural gases using interchangeability indices.

An introduction will be provided to the subject as well as an overview of the historical R&D completed to get to the current position on gas interchangeability and gas quality specifications. This will highlight the differences between UK, European and USA definitions of the interchangeability parameters.

## 2.1 Combustion Description

- What is combustion? Combustion chemistry can give rise to a whole range of reaction products, when ideally all we want to produce is carbon dioxide and water. This section explains why, and what factors need to be taken into account to stay in control of the process.

## 2.2 Interchangeability

### 2.2.1 Interchangeability Parameters

- How do we describe interchangeability, and why? A complete list of interchangeability parameters is provided here, including explanations for the Wobbe Index, Lift Index, Incomplete Combustion Factor and Soot Index.

### 2.2.2 The Dutton Diagram

- In the 1980s Geoffrey Dutton of British Gas derived an empirical description of the envelope of acceptable gas qualities for natural gas in the UK. This pioneering work led to the so-called Dutton Diagram. This section explains the basis of the Dutton diagram and how it can be used to plot impacts of gas quality, including the example of LNG ballasted with a range of nitrogen compositions.

### 2.2.3 Industrial & Commercial Gas-fired Equipment

- Gas quality affects combustion processes from domestic through to industrial. This section provides a case study describing the impact of gas quality on glass-fibre manufacture.

## 2.3 Country Gas Quality Programmes

- Different countries have come to describe their interchangeability issues in a number of different ways. This section gives several examples and describes the national/regional initiatives developed to achieve harmonised gas quality standards.

### 2.3.1 UK Gas Quality Programme

- The completed test programme led by the UK government, leading to the recent decision on the UK strategy for dealing with new gas imports.

### 2.3.2 Europe Follows UK Programme

- The development of EASEE-gas standard for cross-border trading across EU member states, and work by CEN, the European Standardisation Department.

### 2.3.3 United States

- The recognition of Wobbe Index and initiatives to converge towards harmonised standards through the National Gas Council.

### 2.3.4 Far East

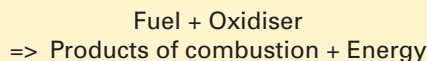
- The Far East occupies a unique position in gas quality standardisation, with Japan being a mature LNG based market and Korea and China as emerging gas users. Their respective efforts in gas quality standardisation are discussed.

### Appendix 2.1

Descriptions of Key Interchangeability Parameters.

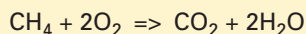
## 2.1 Combustion Description

Combustion is the conversion of a substance called a fuel into chemical compounds known as products of combustion by combination with an oxidizer. The combustion process is an exothermic chemical reaction, i.e. a reaction that releases energy as it occurs. Thus combustion may be represented symbolically by:

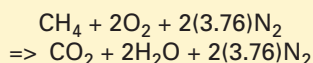


The released energy can be in the form of heat and light.

Methane (CH<sub>4</sub>), is a common fuel that is a major constituent of most natural gases. Consider a complete combustion of methane in pure oxygen (O<sub>2</sub>), carbon dioxide (CO<sub>2</sub>) and water (H<sub>2</sub>O) are produced. The chemical reaction equation for the complete combustion of methane in oxygen may be written as:



However in the majority of combustion processes air is used rather than pure oxygen. The same combustion products are expected as with combustion in oxygen; the only additional reactant present is nitrogen (N<sub>2</sub>), and it is considered inert. Moreover, because we know that in air every molecule of oxygen is accompanied by 3.76 molecules of nitrogen (there is approximately 21% oxygen in air and the rest is assumed to be nitrogen so the factor is 79/21 or 3.76), the reaction equation can be written as:



So a rough rule of thumb is that there is a 1:10 volume ratio for natural gas combustion in air, i.e. 1:(2+(2×3.76)) or 1:9.52.

This approach of creating a balanced chemical relationship leads to a consideration of stoichiometry, equivalence ratio, excess air and stoichiometric ratio. All these terms relate to the amount of fuel and air used in the combustion process and how close the ratio is to the theoretical, balanced chemical equation. The use of a range of terms is confusing as different companies and countries favour different approaches.

Stoichiometry ( $\lambda$ ) or stoichiometric ratio relates to the amount of fuel used compared to the fuel required for complete combustion (the balanced chemical equation shown above). A value of one is the balanced system; values lower than one have too much air (or too little fuel) and are termed "lean" mixtures whereas values greater than one have too much fuel or too little air and are termed rich mixtures.

$$\lambda = \text{fuel} / \text{fuel(s)}$$

where fuel is the amount of fuel and fuel(s) is the amount of fuel for a perfectly balanced system for complete combustion

Equivalence ratio ( $\phi$ ) is similar to stoichiometry except that it considers both the fuel and air rather than just the fuel alone. Again it is a ratio but here it is the ratio of the fuel/air values for both the actual and for complete combustion. As an equation this is:

$$\phi = (\text{fuel/air})_{\text{actual}} / (\text{fuel/air})_{\text{stoic}}$$

Values of ( $\phi$ ) greater than one are rich mixtures with more fuel than can be completely combusted. Values of ( $\phi$ ) less than one are lean mixtures with more air than is required for complete combustion. Equivalence ratio ( $\phi$ ) links with excess air in that:

$$\begin{aligned} & (\% \text{ excess air}) \\ & = (\% \text{ theoretical air requirement}) - 100\% \end{aligned}$$

where:  $f = 100 / (\% \text{ theoretical air requirement})$

Although we have represented the combustion process as a simple balanced equation, it is actually far from being simple as it involves a large number of individual chemical reactions that give rise to intermediate reaction products. Figure 2.1 shows a representation of the conversion of methane to carbon dioxide and the wide range of intermediate chemical species involved in the process (the size of the arrow indicates if the process is a major or minor route).

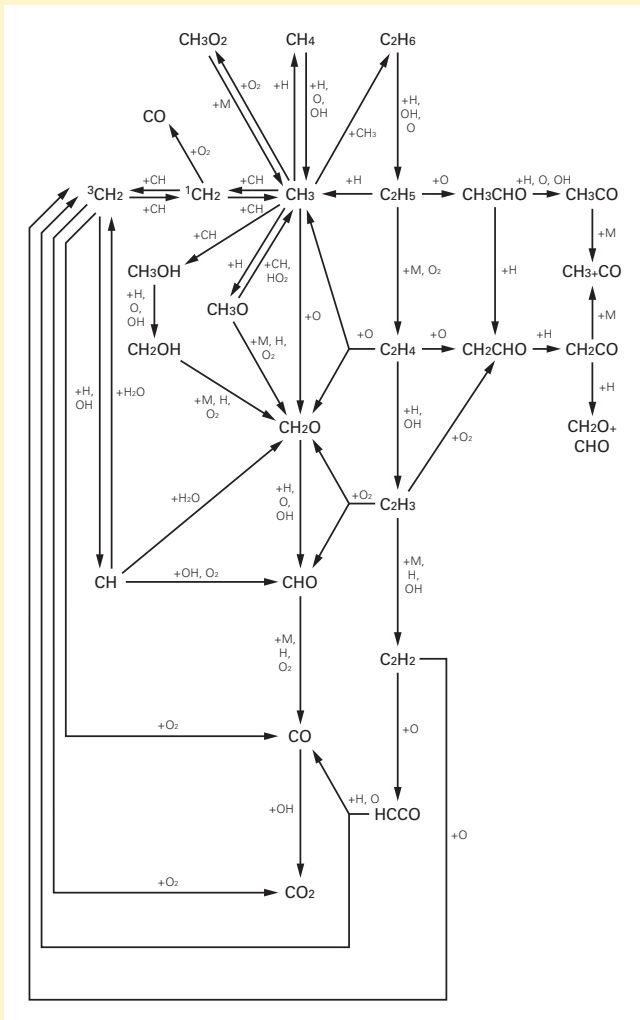
If there is insufficient oxygen to completely react with all the fuel then the conversion process will stop before carbon dioxide is produced, and carbon monoxide (CO) can become a major product species. So for rich combustion carbon monoxide is often a significant product.

As well as carbon monoxide and carbon dioxide, other pollutant species can result from the combustion process including:

- Oxides of nitrogen (NO<sub>x</sub>).
- Soot and particulates.
- Oxides of sulphur (SO<sub>x</sub>).

For the majority of world traded natural gases the levels of sulphur are low and levels of soot/particulates produced are also relatively low. The major pollutant species is NO<sub>x</sub> and there are three major pathways for NO<sub>x</sub> formation:

1. **Fuel NO<sub>x</sub>** – this is formed by oxidation of nitrogen compounds in the fuel itself. Natural gas does not contain any fuel-bound nitrogen and so this mechanism is not significant for this fuel-type (It is significant for coal though).
2. **Prompt NO<sub>x</sub>** – this is formed by the reaction of hydrocarbon fragments with nitrogen and their subsequent oxidation, but this typically only accounts for a small fraction of the total NO<sub>x</sub> for most burners.
3. **Thermal NO<sub>x</sub>** – this is the formation of nitric oxide (NO) from the oxidation of molecular nitrogen at high temperature. It is this mechanism by which most NO is formed when natural gases are combusted. The key aspect here is the combustion temperature; lower temperatures generally give rise to lower NO<sub>x</sub> emission.

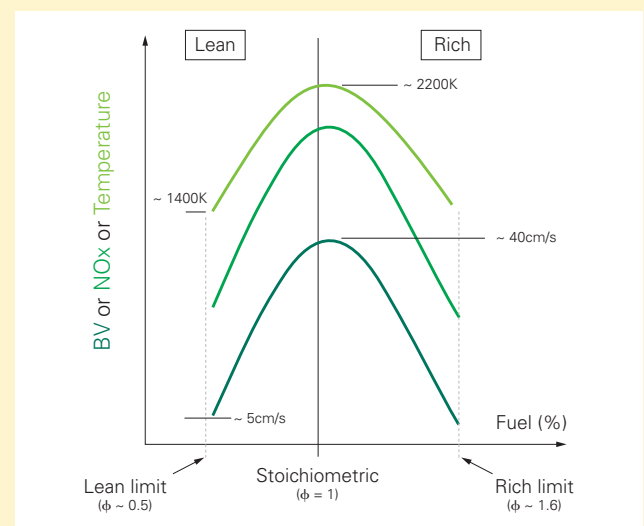


**Figure 2.1** – The Complexity of Methane Oxidation.  
(Source: [www.ivr.uni-heidelberg.de/groups/readflow](http://www.ivr.uni-heidelberg.de/groups/readflow))

As has been shown combustion is a complex chemical process but we often see the process as flames. A flame is defined as a zone where the rapid combustion reaction is occurring with the resultant production of heat and light. A flame can only be sustained if the balance of fuel and air is correct. Too little fuel and the combustion process will not be self-sustaining. Too little air and the fuel will act to quench the overall reaction and the flame will go out. This defines fuel/air mixtures that are flammable, and introduces the terms flammability limits (Lower and Upper) which for natural gas are approximately 5 - 15% gas in air.

A flame moves or propagates at a given speed through a flammable mixture. It will propagate upstream in a flow of a combustible mixture if its burning velocity, BV exceeds the flow velocity. If a fixed flame front is to exist at a fixed location in a duct flow in which the velocity of the combustion gas stream exceeds the propagation speed, some form of flame stabilisation is required. Otherwise the flame front is swept downstream and “flame-out” occurs (also termed “blow-off”). Stabilization may be achieved by using fixed “flameholders” (partial flow obstructions that create local regions of separated flow in their bases where the burning velocity is greater than the local flow velocity) or by directing a portion of the flow upstream to provide a low-speed region where stable combustion may occur.

The burning velocity, flame temperature and NOx production are linked to equivalence ratio:



**Figure 2.2** – Schematic of NOx Formation, Flame Temperature and Laminar Burning Velocities.

As gas quality changes, it moves away from the preset, optimised equivalence ratio for the combustor. This would result in consequences such as incomplete combustion, high NOx emissions and flame instability if no control is put in place.

## 2.2 Interchangeability

**The driving force for establishing rules of interchangeability focuses on safety and operability for domestic, commercial and industrial applications. In the UK, concerns over long term supply of natural gas from UK Continental Shelf (UKCS) led to the development of interchangeability methodologies to ensure supply security, if indigenous stocks declined.**

All burners and combustion systems are optimised for specific fuel types and characteristics. Whilst burners can tolerate some variation in properties the fuel has to be manipulated to ensure that it suits the equipment.

The concept of gas interchangeability was initiated in the USA and Europe more than 30 years ago. However, since there was limited international gas trading at the time and each country focussed on their own gas equipment there was no drive to develop a consistent, internationally recognised interpretation of gas interchangeability.

In the UK, the interchangeability of natural gases has been accommodated for several years as there are many indigenous gas qualities depending on the source around the UKCS. This degree of variability is high relative to much of Europe. To cater for this potential for variation, the UK gas industry developed a semi-quantitative approach for gauging the suitability of gases. The approach was primarily aimed at domestic appliances, although the concepts also carry forward to commercial and industrial users.

**Any apparent UK bias in developing the arguments in this chapter stems from this position, but the development of the concepts can be seen to have a global relevance.**



### 2.2.1 Interchangeability Parameters

**Wobbe Index, which defines the rate of combustion energy generation, is the most accepted parameter for interchangeability. In the UK, the Lift Index (LI), Incomplete Combustion Factor (ICF) and Soot Index (SI) which related to non-optimum performance are also considered. In other countries, some other interchangeability parameters have also been used.**

The essence of natural gas interchangeability relies on knowing heat input delivered to a burner through a fixed orifice. The Wobbe Index, a measure of this heat input, is presented below in its definition from the American Gas Association Bulletin No. 36.

#### Wobbe Index Explanation

(From American Gas Association Bulletin no 36)

The Wobbe Index, or Wobbe Number, of a fuel gas is found by dividing the High Heating Value of the gas by the square root of its Specific Gravity relative to air. The higher the Wobbe Index of a gas, the greater the Heating Value of the quantity of gas that will flow through a hole of a given size in a given amount of time.

In almost all gas appliances, the flow of gas is regulated by making it pass through a hole or orifice.

The usefulness of the Wobbe Index is that for any given orifice, all gas mixtures that have the same Wobbe Index will deliver the same amount of heat.

Wobbe Index =

$$\text{Higher Heating Value} / \sqrt{\text{Relative Density}}$$

Even though Wobbe Index has become the most accepted parameter for describing interchangeability, many other parameters are being used across the world. In many cases, including the UK, more than one factor may be used to set maximum and minimum thresholds which form an envelope of acceptable operation for downstream plant and equipment. The following factors are used and a short description of each is provided in Appendix 2.1.

- Higher Heating Value or Gross Calorific Value (HHV or GCV).
- Lower Heating Value or Net Calorific Value (LHV or NCV).
- Wobbe Index or Wobbe Number (WI or WN).
- Modified Wobbe Index or Modified Wobbe Number (MWI or MWN).
- Relative Density or Specific Gravity (RD or SG).
- Lift Index (LI).
- Incomplete Combustion Factor (ICF).
- Soot Index (SI).
- Weaver Indices.
- AGA Indices.
- Methane Number.

### Safe and efficient performance is dependent on

- Gas composition.
- Proper burner adjustment.

### Performance problems

- Yellow tipping (carbon monoxide and soot).
- Lifting (noise, carbon monoxide, efficiency).
- Flashback (noise, flame out, equipment damage).

These additional parameters result from experimentally determined "indices" from measurements on real appliances extended through empirical relationships. The "indices" developed are classified as:

- Lift index.
- Incomplete Combustion Factor.
- Soot index.
- Light-back.

*(NB. Whilst light-back is a serious characteristic to avoid, since most natural gases do not contain hydrogen this factor will not be discussed further. Please refer to Appendix 2.1 for the definitions of these indices.)*

Different countries may use different parameters to describe interchangeability. In subsequent section, we will use one of the well-known interchangeability methodology – the Dutton Diagram to illustrate how the UK system uses Dutton Diagram to represent interchangeability.

The UK approach recognised that different domestic appliances were more susceptible than others to particular changes in operation and the malfunction types mentioned above.

- The Incomplete Combustion Factor was most important for instantaneous water heaters, which may have short periods of operation under cold start-up conditions and therefore may be susceptible to peaks of high emissions.
- The Lift Index was identified for cooker hobs which require flame stability under controlled turndown.
- The Soot Index was most relevant for radiant fires with white ceramic radiants where sooting would be undesirable, not for safety but more from an aesthetics viewpoint.

## 2.2.2 The Dutton Diagram

**The "Dutton Diagram" is a graphical representation of the interchangeability characteristics. Wobbe Index is plotted against the concentration of propane and nitrogen, corresponding to the higher hydrocarbon and inert equivalence. The diagrams for natural gas with hydrogen and nitrogen-ballasted LNG are also illustrated here.**

The method developed by the UK gas industry applied to natural gases and also gases containing hydrogen. It took the basic understanding of flame phenomena relating to flame temperature and burning velocity, and incorporated appliance effects.

It was recognised that the content of higher hydrocarbon and inert gas species present in the gas had an impact on flame characteristics but Dutton wanted to develop a simplified approach and came up with the concept of equivalent mixtures where the range of hydrocarbons can be represented by amounts of standard hydrocarbons (methane and propane). For inert gas species, the approach collected all the inert gas species as a standard inert, namely nitrogen.

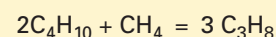
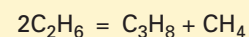
The method works because the burning velocity of different linear alkane hydrocarbons is similar and the impact of inerts is relatively similar also. The equivalent mixture approach must conserve the "number of molecules" to ensure that standard gas laws relating to gas volume are maintained. The inert gas species produce equivalence through the impact on the Wobbe Index.

To account for hydrogen the basic approach is extended but this will not be expanded further here.

### The higher hydrocarbon equivalence grouping

This caters for hydrocarbons other than methane in natural gas and involves:

- Equivalent gas is mixture of methane and propane.
- Same average number of carbon atoms per molecule.
- Same total number of hydrogen and carbon atoms, e.g.



where:  $\text{C}_2\text{H}_6$  = Ethane  
 $\text{C}_4\text{H}_{10}$  = Butane

As can be seen the total number of carbon atoms and hydrogen atoms balances either side of the chemical equation and in this example ethane and butane can be represented as methane and propane.

### The inert equivalence grouping

Here nitrogen is the standard inert and all other inert species (for example carbon dioxide) have an equivalent nitrogen level such that amounts of inert gas which, when mixed with all of the non-inert components, gives a mixture with the same Wobbe Index as the original mixture.

The graphical representation of the interchangeability characteristics has become known as the Dutton Diagram, which is a three dimensional diagram if hydrogen is considered but for the majority of natural gases around the world a two-dimensional representation suffices.

To understand the basic development of the diagram, first the Wobbe Index is plotted as a function of the percentage of propane and nitrogen (also called the non-methane component, or sometime the propane-nitrogen number). This is shown below:

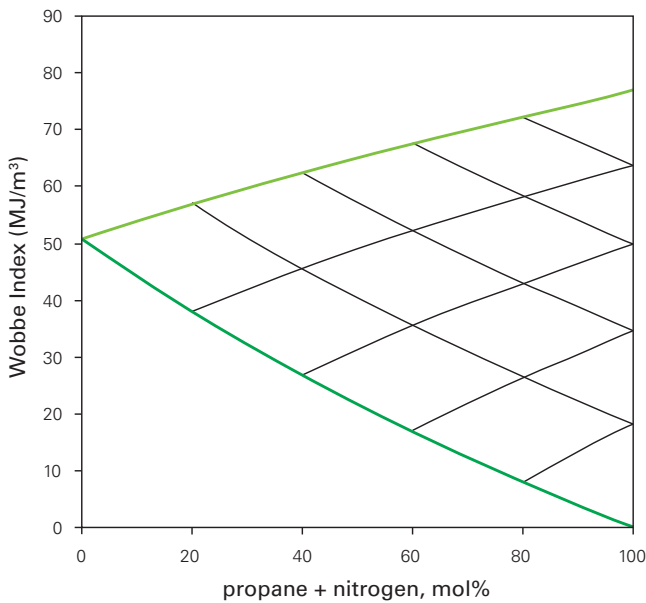


Figure 2.3 – The Basis of a Dutton Diagram.

As the addition of propane or nitrogen moves from left to right across the diagram the region to the left of the propane/methane and nitrogen/methane lines cannot be accessed and no natural gas mixtures can reside with those regions. The meshed region is the range of available gas mixtures.

The range of practical gas mixtures cannot cover levels of propane and nitrogen up to 100% as the mixtures would be classified as liquefied petroleum gas (LPG) or as a mixture outside of the normal flammable range.

In the UK the natural gas specification is set by the Gas Safety (Management) Regulations (GS(M)R), via the Health and Safety Executive and the National Grid gas quality entry conditions. These use the Wobbe Index as the main parameter of interchangeability, but also use limits for Incomplete Combustion and Soot Index.

The acceptable range of gas qualities are, therefore, further restricted. Incomplete Combustion Factor gives an upper bound, Soot Index presents a right hand limit while the Lift Index limits the lower bound. Figure 2.4 shows the pictorial form of the Dutton diagram developed in the UK, with the GS(M)R limits for the appliance performance related indices incorporated.

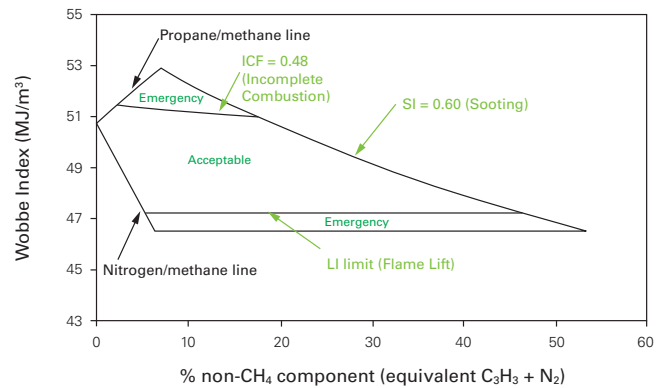


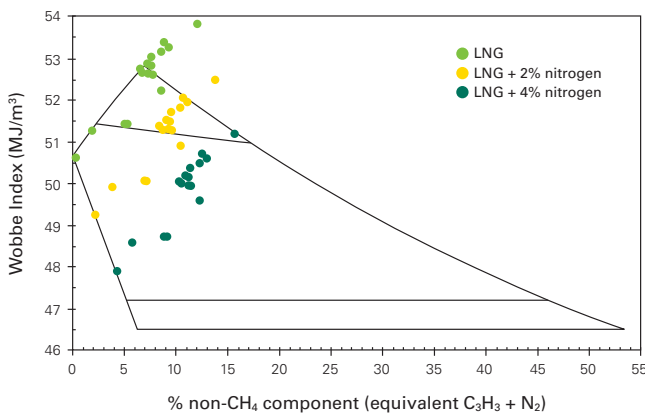
Figure 2.4 – Dutton Diagram with GS(M)R Limits.



### Nitrogen Ballasting

Perhaps the most common method of bringing rich gases back within specification is ballasting with nitrogen. Indeed many liquefied natural gas (LNG) importation plants already incorporate nitrogen injection facilities. This area will be dealt with more thoroughly in Chapter 7, but of specific interest here is how this affects the Dutton diagram.

The example below shows the impact of taking a range of LNG compositions, and ballasting with 2% and 4% nitrogen. As can be seen, 4% nitrogen is sufficient to bring all LNG compositions but one inside the acceptable range for UK network entry.

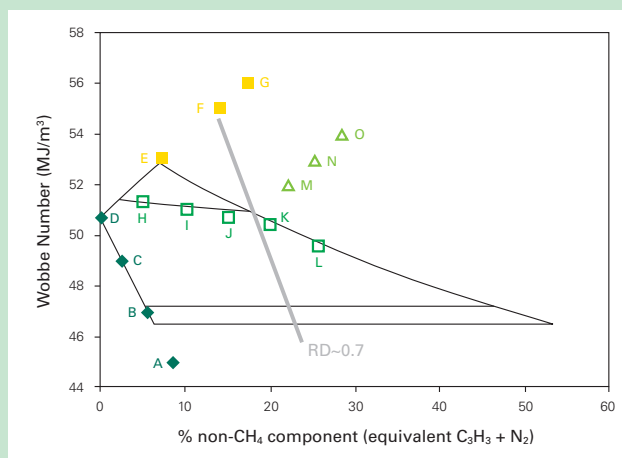


**Figure 2.5** – Dutton Diagram Showing the Effect of Nitrogen Ballasting.



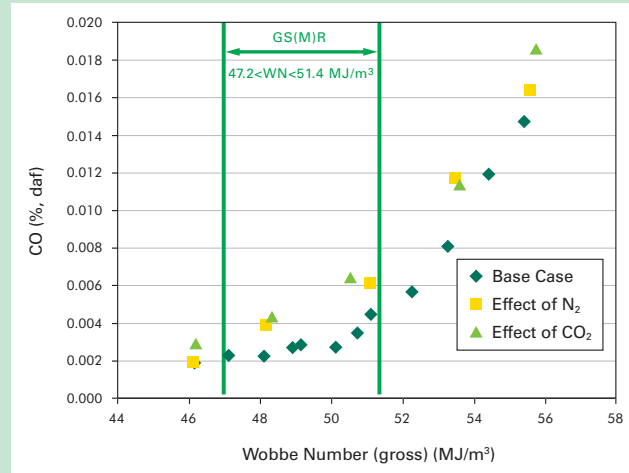
## Case Study 2.1 UK Appliance Test Programme

As part of the UK appliance test programme, 15 gases were used to test some 25 different UK appliance types representing more than two-thirds of the UK appliance population, as plotted in the Dutton diagram of Figure 2.6. Potentially there are conflicting targets of maintaining security of gas supply and ensuring safety of end-users with no reduction in energy efficiency and no increase in energy costs.



**Figure 2.6** – Dutton Interchangeability Diagram Showing Test Gas Properties.

The test programme was designed to be as representative as possible of the UK's existing gas appliance population, primarily focusing on appliances manufactured and certified to the requirements of EC Directive 90/396/EEC (the "Gas Appliance Directive" or GAD). The testing was on both new and used appliances with the objectives of establishing the impact on combustion performance and emissions of operating on test gases at, and beyond, the GS(M)R limits, measuring emissions and efficiency performance. The effect of 'diluting' natural gases with an inert gas such as nitrogen was also examined such that regasified LNG with nitrogen ballast was examined.



**Figure 2.7** – Effect of Natural Gas 'Dilution' with Nitrogen and Carbon Dioxide

It might be expected that modern appliances would be less influenced by a change in the Wobbe Index than older models. However, the drive for higher efficiency and reduced emissions has led to the new appliances tending to have burners accepting a narrower range of Wobbe Indices, in effect being tuned to the expected gas quality specification. This is illustrated in Figure 2.7 showing how carbon monoxide emissions increase as the Wobbe Index is raised beyond the GS(M)R limits. Carbon monoxide is a colourless, odourless gas which accounts for between 10 - 20 fatalities per year in the UK from piped natural gas combustion equipment. Clearly such a significant increase in emissions when appliances operate outside the existing GS(M)R limits indicates how well the equipment is designed for current gas specifications but also how rapidly performance deteriorates beyond the high limit.

As a summary of the results from the test programme, it was reported that:

- Ignition was OK for all test gases.
- Flame lift was not generally a problem.
- Little or no soot measured in the flue gas, but some deposited on the decorative coals of the fires (for the higher Wobbe Index test gases).
- NO<sub>x</sub> emissions increased as the Wobbe Index increased.
- Little change in efficiency with Wobbe Index change.
- CO emissions increased with Wobbe Index.

These results included the regasified LNG with ballasted nitrogen addition. More information on the Gas Quality Programme and the test results can be found on the web at:

[www.berr.gov.uk/files/file20965.pdf](http://www.berr.gov.uk/files/file20965.pdf)

### 2.2.3 Industrial & Commercial Gas-fired Equipment

**Industrial and commercial gas-fired equipment should be more tolerant to a wider range of Wobbe Index and calorific value due to the investment in more sophisticated process controls such as air/fuel ratio and flue-gas feedback/trim control systems. However the consequences in lost production or heating services could be large to individual customers who may be affected by gas quality changes.**

There are a number of industrial processes which would be particularly sensitive to a change towards gas with a higher Wobbe index. As already indicated, gas turbines for power generation are particularly sensitive to rapid changes in gas quality.

Other examples of processes and equipment that could be adversely affected:

- Float glass and fibreglass production.
- Furnaces with controlled atmospheres.
- Ceramics and glazing processes.
- Gas engines.
- Direct fired textile processes.

These applications are considered in more detail in Chapter 6.



#### Case Study 2.2

#### Impacts of Gas Quality on Downstream Processes

This summarises the results for gas quality tests on catalytic combustors and the glass-fibre manufacturing process. More details are discussed in Case Study 6.4 and Case Study 6.6 in Chapter 6.

#### Catalytic Combustion

Catalytic combustion in natural gas fired turbines is a technology being developed for ultra-low NO<sub>x</sub> emissions. Research in the United States has been performed using small-scale catalyst modules investigating fuel composition variation, with natural gases containing higher hydrocarbons and inert gases to simulate a range of gas qualities.

The test results show that the majority of the gases tested resulted in calculated “operating window” shifts of less than 20°C, which is within the tolerance of catalytic combustors. Hence, it confirms the ability of catalytic combustors to run on a wide range of natural gas compositions.

#### Glass-fibre Manufacture

Variations in gas quality, in particular the oxygen concentration, in a glass manufacturing process can lead to glass imperfections and breakage, leading to loss of production.

Manually changing burner controls to re-establish optimum combustion performance is an intermediate remedy to the problem. However, a long-term practical solution should involve integral process control.

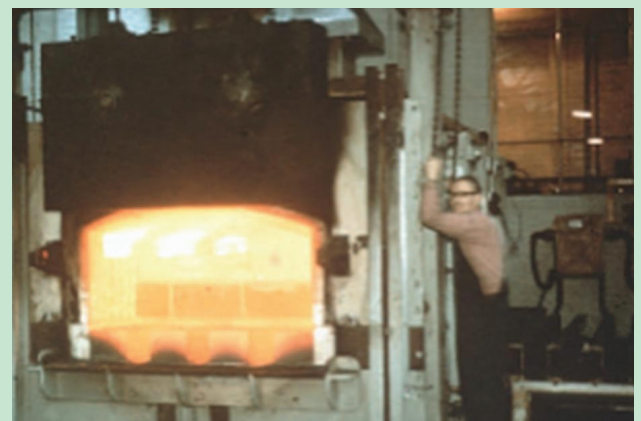


Figure 2.8 – Gas-fired steel reheat furnace.

## 2.3 Country Gas Quality Programmes

Changes in flame shape and radiation temperatures, could affect most of the above industrial processes.

Insufficient availability of combustion air could be the key issue, leading to sooting, poor combustion and ignition problems. As an example, one equipment type which would be affected is the commercial direct fired air heater which typically has a wide turndown but has a single speed fan providing a fixed air flow rate.

In Chapter 6 the impact of changes in gas quality on different domestic, commercial and industrial gas-fired plant will be explained, highlighting the issues of equipment performance in terms of safety, emissions and efficiency. The sensitivity of certain industrial processes to changes in gas quality will be stressed and a discussion given on gas turbines, where rate of change of gas quality is important.

Having defined the Wobbe Index and explained the significance of the gas interchangeability diagram, we can now describe how combustion performance of downstream equipment can be mapped on to the Dutton diagram (Figure 2.4). We can also see how variations in gas quality, in particular regasified LNG from different sources, can alter the performance of equipment and its location within the boundaries of acceptable operation (Figure 2.5).

In order to explain the issues confronting national governments worldwide regarding security of supply of natural gas, and gas interchangeability, we will again use the UK as an example, as a public consultation process has been recently completed.

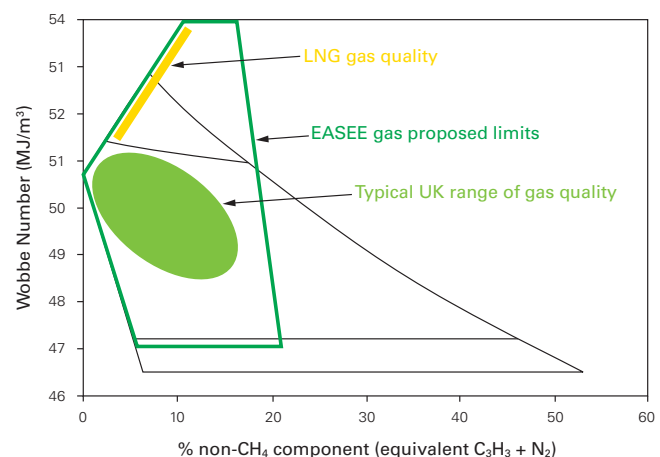


### 2.3.1 UK Gas Quality Programme

**An appliance testing programme has been led by the UK government (DTI, now DECC) to identify the impact of various gas quality conditions on gas appliances. The UK is facing a challenge in maintaining the security of supply with minimal cost and performance impacts on the end-users.**

The depleting gas fields in the North Sea have brought issues of gas supply security to a number of European countries. Several new gas pipeline interconnectors are being constructed along with new LNG importation terminals. In order to facilitate and streamline increased gas trading across international borders, European gas transporters, now supported by the rest of the European gas industry, created a new organisation to develop and promote common business practices. This organisation, the European Association for the Streamlining of Energy Exchange-gas or EASEE-gas, is supported by the European Commission and the European Regulators and one of its aims is to create a Harmonised Gas Quality specification.

Expressed on the interchangeability diagram of Figure 2.9, this shows that the UK GS(M)R allow a range of Wobbe Index between 51.41 - 47.20 MJ/m<sup>3</sup> for acceptable appliance operation. This is compared with the proposed EASEE-gas range of 54.00 - 46.45 MJ/m<sup>3</sup> with a Relative Density or Specific Gravity limit of less than 0.7.



**Figure 2.9** – Dutton Diagram Showing GS(M)R and EASEE-Gas Range.

In response to this likely harmonisation of future European gas quality specifications the UK Government has led a programme of work to identify the issues for the UK. The work assessed appliance performance under various gas quality conditions and informed consultation with industry on future policy. Potentially there are conflicting targets of maintaining security of gas supply and ensuring safety of end-users whilst ensuring no reduction in energy efficiency and minimum increase in energy costs.

### 2.3.2 Europe Programme

---

**A harmonised gas quality standard – “EASEE-gas” is proposed to overcome the barrier for cross-border trading across EU member states. A two-stage approach is being managed by CEN (The European Committee for Standardisation) to campaign for the adoption by member states within three years.**

---

EC Directive 2009/73/EC has the objective of creating a fully operational internal natural gas market with common rules for transmission, distribution, supply and storage of natural gas. The differences in gas quality specifications across EU member states have been seen as a barrier to cross-border trade. Encouragingly, a new mandate from the European Commission requires CEN to implement a harmonised gas quality standard based on EASEE-gas common best practice.

Representatives of gas transporters and other interested parties from Europe are working to agree common gas quality standards.

In a two-stage approach CEN will manage:

- A survey and analysis of the installed gas appliance population across Europe with a test programme for a selection of representative appliances (similar to the UK programme); and
- Followed by work to modify EN standards on high calorific gas (so called H gas) quality such that member states adopt the new standards within three years.

The likely outcome will be an agreed harmonised European gas quality specification where interchangeability is addressed with a Wobbe Index range wider than most current European country specifications. The impact will therefore be that some European countries may be able to accept regasified LNG with little or no requirement for processing.

As of October 2011, EC is consulting on interoperability, including gas quality, with a view to drawing up Framework Guidelines.

### 2.3.3 United States

---

**Convergence with Europe is observed when the Wobbe Index is recognised as the key interchangeability parameter, alongside supplementary limits in High Heating Value, Higher Hydrocarbons C<sub>4</sub>+ and Total Inerts. A project team has been formed to achieve harmonised standards.**

---

In the USA, the Natural Gas Council (NGC), comprising four major industry organisations – American Gas Association (AGA), Natural Gas Supplier Association (NGSA), Interstate Natural Gas Association of America (INGAA) and Independent Petroleum Association of America (IPAA), has organised a NGC+ workshop with not only technical representatives from NGC, but also natural gas stakeholders tasked by the Department of Energy (DOE) and the Federal Energy

Regulatory Commission (FERC) to address the issues of gas interchangeability. North America has several new LNG importation terminals under construction or at the planning stage. The USA generally has state-by-state regulations and gas specifications or tariffs are based on the historical average Wobbe Index seen in the local state.

An NGC+ white paper has been presented to the FERC recommending an Interim Guideline with  $\pm 4\%$  Wobbe Index limits around the historical local average up to a maximum Wobbe of 1,400 btu/scf, a maximum heating value of 1,100 btu/scf and two more parameters to address interchangeability issues. FERC has used part of the evidence and data provided in this white paper to rule on the gas tariff debates being held in states where regasified LNG is being supplied.

The USA recognition of Wobbe Index as the key interchangeability parameter shows a convergence with other world regions such as Europe. The NGC+ Interim Guideline also includes other parameters such as High Heating Value, Higher Hydrocarbons C<sub>4</sub>+ and Total Inerts. This moves away from the previous USA interchangeability parameters of Weaver and AGA indices developed some 40 years ago.

In addition, in the USA, a project team has been formed under AGA organisation to review AGA Report 4A: Natural Gas Contract Measurement and Quality Clauses and Research Bulletin 36: *Interchangeability of Other Fuel Gases with Natural Gases*.

These initiatives are giving lead gas organisations the opportunity to collaborate on gas interchangeability knowledge in an attempt to converge towards harmonised standards which should improve the ease and accuracy of natural gas trading across the world.

### 2.3.4 Far East

---

**Japan is a traditional LNG market, supplied by high calorific regasified LNG. The Integrated Gas Family (IGF) 21 Plan has been proposed to integrate these LNG areas with LPG fed areas.**

**No gas quality and interchangeability standards currently exist in China. However, the importance of having such standards are recognised and a group has been founded to manage progress in this area.**

---

Gas feedstock to Japan has been dominated by imported LNG. High calorific regasified LNG is supplied to the major urban centres of Japan such as Tokyo, Osaka and Nagoya, whereas liquefied petroleum gas (LPG, consisting of a mixture of propane and butane) is supplied to more localized areas. The Integrated Gas Family (IGF) 21 Plan has been proposed by the government to integrate the supply of gas.

There is no existing national natural gas quality standard in China. The China Natural Gas Standardization Technical Committee (CNGSTC) was founded in 1999 to develop standards in the natural gas industry. Using ISO (International Standardization Organization) as a basis, Chinese national standards for measurement, sampling and

## Appendix 2.1

### Description of Key Interchangeability Parameters

testing methods for natural gas have been established. A LNG Standardization Technology Working Group has also been formed to manage the standards related to LNG.

#### Heating Value or Calorific Value

This represents the energy content of a gas usually given in units of MJ/scm or Btu/scf and can be expressed as Higher Heating Value (HHV, same as Gross Calorific Value where water vapour in combustion is assumed to be entirely condensed and the heat recovered) or Lower Heating Value (LHV, same as Net Calorific Value where the heat of vaporisation is not recovered). Heating value is not the best parameter to represent interchangeability since it does not account for flow through a burner.

#### Relative Density or Specific Gravity

As a measure of gas density relative to air at reference conditions this is used for interchangeability specifications to limit the higher hydrocarbon content of the gas. An increased higher hydrocarbon content could lead to combustion problems such as increased carbon monoxide emissions, soot formation, engine knock or spontaneous ignition on gas turbines even at the same Wobbe Index value.

#### Wobbe Index or Wobbe Number

This is the most widely used interchangeability factor. Wobbe Index is defined as:

$$WI = HHV / (RD_{\text{gas}})^{1/2}$$

where: RD = Relative Density

Since the volumetric flow of gas in a pipe is inversely proportional to the square root of gas density (as is the Wobbe Index), thermal input through a burner nozzle is seen to be proportional to Wobbe Index and not to Heating Value. It can also be shown that Wobbe Index is proportional to the equivalence ratio or stoichiometric air requirement for a burner.

#### Modified Wobbe Index or Modified Wobbe Number

Gas turbines can operate with a large range of fuels, but the fuel variation that a particular installation can cope with is limited. The Modified Wobbe Index (MWI) is used particularly by gas turbine manufacturers. It is important because it takes into account the temperature of the fuel. The Modified Wobbe Index is the ratio of the lower heating value to the square root of the product of the specific gravity and the absolute gas temperature.

$$MWI = LHV / (RD_{\text{gas}} T_{\text{gas}})^{1/2}$$

Any change in the fuel's heating value will require a corresponding change in the fuel's flow rate to the machine, incorporation of temperature effects is important in calculating energy flows in turbines where a large input temperature variation is possible. The allowable MWI range is established to ensure that required fuel nozzle pressure ratios are maintained during all combustion/turbine modes of

operation. For older, diffusion-type combustors, the gas turbine control system can typically accommodate variations in the Modified Wobbe Index as large as  $\pm 15\%$ . But for newer, dry low NOx (DLN) combustors, variations in the MWI of only  $\pm 3\%$  could cause problems.<sup>1</sup> The corresponding velocity changes through a DLN system's precisely sized fuel-nozzle orifices can cause flame instability, resulting in pressure pulsations or "combustion dynamics", which can, in the worst case, destroy the combustion system.

#### Methane Number

The main parameter for rating the knock resistance of gaseous fuels is the Methane Number (MN), which is analogous to the Octane Number for gasoline. To ensure safe engine operation the Methane Number must always be at least equal to the Methane Number Requirement (MNR) of the gas engine. The Methane Number required by the engine is affected by design and operating parameters, with the adjustment of the Methane Number Requirement being achieved by changing engine operation. Changes in ignition timing, air/fuel ratio and output are effective measures to reduce the Methane Number Requirement.

Different scales have been used to rate the knock resistance of compressed natural gas (CNG) including the Motor Octane Number (MON) and the Methane Number. The differences in these ratings are the reference fuel blends used for comparison to the natural gas. Methane number uses a reference fuel blend of methane, with a Methane Number of 100, and hydrogen, with a Methane Number of 0. Correlations have been generated between the reactive hydrogen/carbon ratio (H/C) and the Motor Octane Number and between Motor Octane Number and Methane Number.

$$\begin{aligned} \text{MON} &= -406.14 + 508.04*(\text{H/C}) \\ &- 173.55*(\text{H/C})^2 + 20.17*(\text{H/C})^3 \text{ MN} \\ &= 1.624*\text{MON} - 119.1 \end{aligned}$$

If a gas mixture has a Methane Number of 70, its knock resistance is equivalent to that of a gas mixture of 70% methane and 30% hydrogen.

#### Incomplete Combustion Factor

This is one of three gas interchangeability factors developed by Dutton of British Gas R&D in the late 1970s. He used representative UK appliances of the time to develop factors which could be calculated to quantify incomplete combustion, flame lift and sooting from known gas compositions. His interchangeability diagram plots percentage non-methane as an equivalent propane and nitrogen mixture against Wobbe Index.

For Incomplete Combustion he considered instantaneous water heaters to be the most sensitive appliance and therefore developed tests, and his Incomplete Combustion Factor (ICF), from these. Incomplete Combustion Factor is in effect the number of times the CO/CO<sub>2</sub> ratio (the combustion performance ratio) of the reference gas has to be doubled to give that of the test gas. Assuming no hydrogen content:

<sup>1</sup>EPP1 report "Fuel Composition Impacts on Combustion Turbine Operability", March 2006.

$$ICF = (WN - 50.73 + 0.03PN) / 1.56$$

where: WN = Wobbe Index, PN = Sum % by volume propane and nitrogen in an equivalent mixture

The UK GS(M)R limit is Incomplete Combustion Factor <0.48.

### Lift Index

This is based on Dutton's assessment of flame detachment from burner ports under different conditions. Here the test appliance was a cooker hob, and the assessment of flame detachment from the burner port was determined from an empirical relationship between Lift Number and Propane – Nitrogen Number.

- Lift Index (LI) is the average "Lift Number" from 0 to 6 (0 is no visible detachment of flame base and burner and 6 is complete detachment of 50 - 100% of the flames)
- Propane Nitrogen Number is the sum of percentages of propane and nitrogen in an equivalent mixture of methane propane and nitrogen having the same Wobbe Index as the real gas.

This resulted in a plot of Lift Index as a function of Wobbe Index (WI) and Propane–Nitrogen Number (PN) and the empirical fit to the test results was:

$$LI = 3.25 - 2.41 \tan^{-1} \{ [0.122 + 0.0009H_2] (WI - 36.8 - 0.0119PN + (0.775 - 0.118PN^{1/3}) H_2) \}$$

### Soot Index

Soot Index (SI) is calculated as the burner aeration that produces soot divided by the natural aeration of the burner (previously measured), the primary aeration to the appliance being reduced in stages. Quite limited to UK application, the test appliances used by Dutton to examine sooting were radiant gas fires. Here the problem was at the time seen more as an aesthetic (black sooting on white ceramic radiants) rather than a safety or reliability issue.

$$SI = 0.896 \tan^{-1} (0.0255C_3H_8 - 0.0233N_2 + 0.617)$$

where: C<sub>3</sub>H<sub>8</sub> and N<sub>2</sub> = % by volume propane and nitrogen respectively in the equivalent mixture)

The UK GS(M)R limit is Soot Index < 0.6.

### Weaver Indices

Weaver had developed several interchangeability indices in 1950s in the USA. For example, one of the indices, the Weaver Flame Speed Factor was determined from formulae and graphs and was satisfactory for town gas compositions of the time where performance was dependent on hydrogen levels and the burning velocity of the gas mixture. However, natural gas is generally hydrogen-free with a consistent Weaver Flame Speed Factor of 14.

### AGA Indices

These factors were developed by the American Gas Association and first published in the 1940s in Research Bulletin 36: Interchangeability of Other Fuel Gases with Natural Gases. The work used a specific flame characteristic test burner and derived indices for calculating the interchangeability of gases of HHV = 800 Btu/scf or less (well below today's natural gases with HHV in excess of 1,000 Btu/scf). Calculations were given for the stoichiometric air requirement, and indices for flame lifting, flashback and yellow tip interchangeability. Again, these parameters were accurate for the burner tested and appliance types at the time but are not appropriate for the high efficiency, low emissions burner technology prevalent today. AGA are currently reviewing and updating Bulletin 36.





## Chapter 3

### International Standards and Country Regulations

National standards around the world relating to gas quality and interchangeability have evolved on a largely independent basis. This chapter summarises the international position and discusses the roles of regulation and legislation. A wide range of gas quality parameters for a cross-section of countries is tabulated.

The chapter also covers the work of a number of gas industry over-arching organisations including the European Standards Committee (CEN), the European Association for Streamlining of Energy Exchange (EASEE-gas) and the American Gas Association (AGA), in harmonising gas quality definitions and reference conditions.



## 3.1 Background

- How were the national gas quality standards developed and who are the regulators responsible for this? This section discusses the historical background relevant to national standards.

## 3.2 Gas Quality Regulations and Legislation

- Market liberalisation has encouraged the division of national gas supply organisations into production, transmission, distribution and retail companies. Contractual agreements on the gas quality transferred between parties are vital to avoid disputes. There is an increasing number of national, provincial and local regulatory bodies that engage with industry associations to develop and promote appropriate gas quality standards and regulations for security of gas supply without compromising safety and operations in the transmission and downstream systems.

## 3.3 Gas Quality Definitions and Measurements

- The International Organization for Standardization (ISO) provides recognised standards including gas quality standards, defining best practice for a wide range of calculations, measurements and procedures within the gas industry. In the USA, standards from the American Standards of Testing Measurements (ASTM), Gas Processors Associations (GPA) and American National Standards Institute (ANSI) are typically used. The section explains the importance of reference conditions and analysis standards in the determination of gas quality.

## 3.4 Gas Quality Specifications

- This section gives details on gas quality limitations for various constituents.

### 3.4.1 Network Integrity and Downstream Combustion Safety

- Specifications on the concentrations of components such as water, hydrocarbons, hydrogen sulphide and inerts etc are crucial to prevent network integrity and operational problems. The review and development processes that have happened as supplies have become increasingly diverse are also illustrated.
- A case study on the gas quality specifications in Japan is provided.

### 3.4.2 Odourisation and Operational Safety

- Local gas quality specifications require distributed gas to have a distinctive odour to enable detection of gas leaks by the general public. Different types and levels of odorants are reviewed here.

## 3.5 Country Initiatives

- This section summarises the main initiatives in mainland Europe, UK and USA to develop gas quality standards in the light of increasingly diverse gas supplies.

### 3.5.1 Mainland Europe, UK and USA Initiatives

- EASEE-gas has proposed a harmonised gas quality specification across Europe to overcome barriers for cross-border gas trading. This section explains the EASEE-gas approach, together with the UK conclusion on the future arrangement for Great Britain's gas quality specifications. The studies and programmes launched in the USA on the gas quality issues are also discussed.

### 3.5.2 Convergence

- Europe and USA are moving closer in the definitions and common acceptance for gas quality parameters. However, there is still some way to go in terms of agreeing international standards. This section describes variations in national gas standards and efforts required to reach convergence.

### 3.1 Background

Existing national gas quality standards are based on the historical gas supplies to the country or region, taking into account the design and flexibility of the local downstream gas-fired equipment. With increasing global gas trading, consistent gas quality standards are essential for commercial, operational and safety reasons.

In general, gas quality standards were based on the historic gas supply or supplies received by a country or region or in the case of the USA by individual states. Typically a single national company, for example British Gas in the UK, Ruhr Gas in Germany and Gaz de France, managed the whole gas supply chain. As such they were responsible for the safe transportation of gas that was suitable for all downstream appliances.

Pipelines are traditionally used as the main method of gas transportation. In the past, gas flows were geographically constrained due to the lack of trans-national pipelines. Abundant sources meant that supplies were either local or from specific foreign fields so, as an issue, gas quality remained at national level. In recent years, the increased global trading of natural gas has raised the necessity for international gas quality standards to ensure consistency in billing regimes, and to maintain operational safety and network integrity.

Within each country or region, domestic appliances were optimised by manufacturers and installers to operate on the supplied gas. Industrial users became accustomed to operating their processes within the gas quality range of received gas. Even so, in some countries, transporters and suppliers needed to operate separate networks to accommodate gas supplies and existing users. For example, the German, Dutch, Belgian and French gas industries supply both low and high Wobbe Index gases.

Some countries like Belgium and France have invested in flexible burners where jets can be easily replaced or adjusted in the field. Others, like The Netherlands and Germany have additionally opted for blending different gases during transportation.

In this chapter, gas quality regulations and legislation will be discussed, followed by the definition and measurement of gas quality. Country specifications and initiatives will also be discussed.

### 3.2 Gas Quality Regulations and Legislation

National regulations have been established, particularly in Europe and America, to protect public safety and commercial interests. For instance, in Europe, in the move to define a consistent billing regime, associations such as the Council of European Energy Regulators (CEER) and the Agency for the Cooperation of Energy Regulators (ACER) have been formed to coordinate and integrate activities of national regulatory bodies.

Over recent years many national gas companies have been privatised and, to further encourage competition, progressively split into separate production, transmission, distribution and retail supply companies. In such a competitive environment there is a requirement for contractual agreements to define the quality of gas to be transferred between parties. Public safety overrides commercial interests and countries have imposed regulatory specifications for gas quality. Some examples are:

- Germany** Code of Practice DVGW G 260/I:1983;G 260/II:1990.
- France** Arretes Ministeriels.
- N. America** Natural Gas Act via Federal Energy Regulatory Commission.
- UK** Gas Safety (Management) Regulations (GS(M)R) via the Health and Safety Executive.

Billing regimes are usually defined by statutory laws that are enforced by regulatory bodies. The Council of European Energy Regulators (CEER) is an association of sixteen national regulators; these are listed in Table 3.1. CEER acts as a focal point for contacts between regulators and the European Commission's Directorate for Energy and Transport (DG TREN) and also participates in the Florence Regulatory Process and the Madrid Regulatory Process. It maintains close working relations with regulatory authorities in North America and EU New Member States.

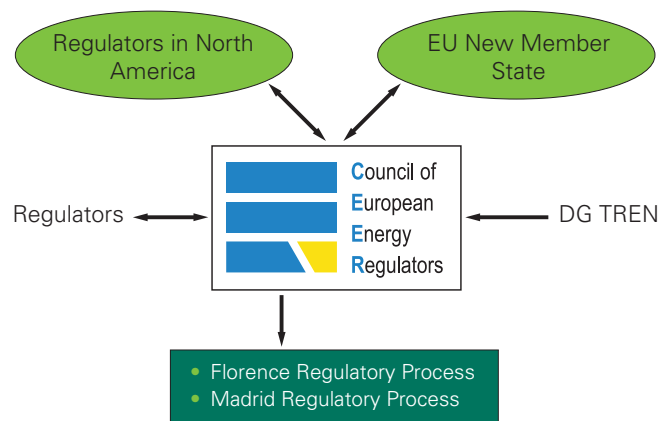


Figure 3.1 – The Role of CEER.

### Florence Regulatory Process

The Electricity Regulatory Forum of Florence was set up to discuss the creation of a single electricity market for the European Commission. The participants are national regulatory authorities, member state government representatives, the European Commission and associations representing transmission system operators, generators, suppliers, traders, distributors and consumers. The Forum convenes once or twice a year, formerly in Florence but now in Rome. The first meeting was held in 1998.

The Forum currently addresses electricity market coupling, the creation of a single pan-European market area, the integration of renewables, and transmission investment.

### Madrid Regulatory Process

The Madrid Regulatory Process is the gas market equivalent of the Florence Regulatory Process. The Forum convenes once or twice a year in Madrid co-hosted by the Fundación de Estudios de Regulación. The first meeting was held in 1999.

The Forum currently addresses capacity allocation and congestion management, infrastructure priorities, the implementation of European legislation within the member states, tariffication, interoperability and LNG.

There is an international move towards customer billing based on measured energy supplied rather than just gas volume based on a single declared gas energy content. This recognises the future variations in gas quality and subsequent energy content likely to be seen by gas consumers.

Countries have, over the years, developed accepted practices relating to the definition and measurement of natural gas quality and these have been incorporated into national standards. However as a consequence of the converging practices within the European market and increased global trading many national standards have been included in and superseded by the European Standards published by the International Organisation for Standardisation (ISO). Each standard is prepared by a Technical Committee comprising the relevant technical expert from each member country.

Such standards may be endorsed by CEN – the COMITÉ EUROPÉEN DE NORMALISATION (European Committee for Standardisation) and published as a European Standard. In accordance with the CEN Internal Regulations, the national standards bodies of the member countries must give European Standards the status of a national standard.

**Table 3.1** – Member European Regulator Bodies of CEER.

Austria	Energie-Control Austria (E-Control)
Belgium	Commission pour la Régulation de l'Electricité et du Gaz (CREG)
Bulgaria	State Energy & Water Regulatory Commission (SEWRC)
Cyprus	Cyprus Energy Regulatory Authority (CERA)
Czech Rep	Energy Regulatory Office (ERO)
Denmark	Danish Energy Regulatory Authority (DERA)
Estonia	Estonian Competition Authority - Energy Regulatory Dept (ECA)
Finland	Energy Market Authority (EMV)
France	Commission de Régulation de l'Energie (CRE)
Germany	Federal Network Agency for Electricity, Gas, Telecommunications, Posts and Railway (Bundesnetzagentur - BNetzA)
Greece	Regulatory Authority for Energy (RAE)
Hungary	Hungarian Energy Office (HEO)
Iceland	National Energy Authority
Ireland	Commission for Energy Regulation (CER)
Italy	Autorità per l'Energia Elettrica e il Gas (AEEG)
Latvia	Public Utilities Commission (PUC)
Lithuania	National Control Commission for Prices and Energy (NCC)
Luxembourg	Institut Luxembourgeois de Régulation (ILR)
Malta	Malta Resources Authority (MRA)
Netherlands	Dutch Competition Authority Energy Chamber (NMa EK)
Norway	Norwegian Water Resources and Energy Directorate (NVE)
Poland	Energy Regulatory Office of Poland (URE / ERO)
Portugal	Energy Services Regulatory Authority (ERSE)
Romania	Romanian Energy Regulatory Authority (ANRE)
Slovak Rep	Regulatory Office for Network Industries (RONI)
Slovenia	Energy Agency of the Republic of Slovenia
Spain	National Energy Commission (CNE)
Sweden	Energy Markets Inspectorate (EI)
UK	Office of Gas and Electricity Markets (Ofgem)

Member countries of CEN: Austria, Belgium, Cyprus, Czech Republic, Denmark, Estonia, Finland, France, Germany, Greece, Hungary, Iceland, Ireland, Italy, Latvia, Lithuania, Luxembourg, Malta, Netherlands, Norway, Poland, Portugal, Slovakia, Slovenia, Spain, Sweden, Switzerland and the United Kingdom.

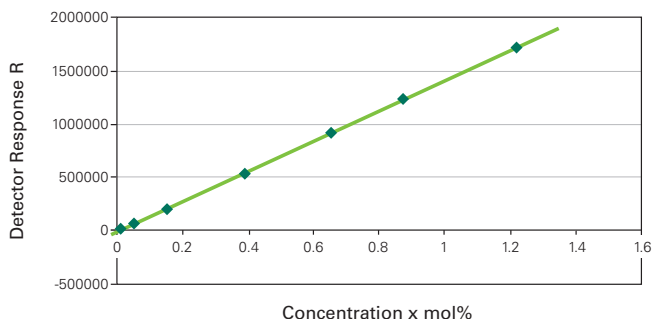
### 3.3 Gas Quality Definitions and Measurements

**The accurate measurement and calculation of any gas quality property is dependant on the physical conditions (mainly temperature and pressure) prevailing at the time of gas sampling and measurement and also the analytical method used. The International Organization for Standardization (ISO) defines the internationally accepted best practice for a wide range of calculations, measurements and procedures carried out within the gas industry.**

One of the most important gas quality standards is ISO 6976: Natural gas – Calculation of calorific values, density, relative density and Wobbe Index from composition, issued in 1995. This standard, and the parameters and calculations it defines, is the cornerstone of metrology within the modern gas industry. The standard describes each gas property, explains how it is calculated and defines the physical properties, such as calorific value for each individual component of natural gas at various combustion and metering reference conditions.

The standards that followed have continued to define internationally accepted best practice for a wide range of calculations, measurements and procedures within the gas industry. As the gas industry has matured and the influence of commercial issues has increased, the standards have been developed to define industry accepted methods and practice that can withstand scrutiny in the event of a contractual dispute.

At the current time, work is in progress to create an international standard that defines a method for calculating hydrocarbon dewpoint from an extended compositional analysis, since results from on-line measurement of hydrocarbon dewpoint are often challenged. ISO 6976:1995 is under technical review to include the calculation of uncertainties associated with the determination of each gas property.



**Figure 3.2 – Iso-butane: Equation of Detector Response.**  
 $R = 1391922 * x$

When specifying parameters or comparing gas data from different sources, it is important to specify reference conditions and units to ensure that a true comparison is made.

Despite the common acceptance of Wobbe Index as the main interchangeability parameter, a variety of units and reference temperatures are used across the world. Table 3.3 shows how different reference condition temperatures for combustion air gas metering affect the Calorific Value and Wobbe Index of the same natural gas.

**Table 3.3 – Importance of Quoting Reference Conditions.**

Pressure, kPa	101.325			
Combustion Air Temperature, °C	15	25	15	0
Metering Temperature, °C	15	0	0	0
Gross Calorific Value, MJ/m <sup>3</sup>	39.37	41.51	41.56	41.62
Wobbe Index, MJ/m <sup>3</sup>	50.00	52.71	52.77	52.85

This will be discussed further in Section 3.5.2

#### Gas Chromatography

Gas chromatography is used to give detailed information on the composition of natural gas from which physical properties (such as the gas interchangeability parameters Wobbe Index and Calorific Value) of the gas are calculated.

ISO10723:2002 defines methods that should be used to evaluate the performance of a gas chromatograph. Presenting the instrument with a number of gases of known composition that are traceable to national or international standards and that cover the composition range of each component provides information on the linearity of the detector and any bias that will result from using a single-point calibration.

An example of the typical response from a gas chromatograph for iso-butane is shown in Figure 3.2. For the range of gases analysed, the instrument's detector was found to have a first order response that passed through the origin. This result means that using single point calibration will produce no bias for this component.

As early as 1993 the International Standards Organisation acknowledged a need concerning the definition of natural gas quality. However, it was not until 2005 that 'EN ISO 13686 - Natural Gas - Quality Designation' was published. The Standard does not specify values of, or limits for, specific gas quality parameters but rather, provides a general statement of each parameter.

### 3.4.1 Network Integrity and Downstream Combustion Safety

Limits on a range of gas quality specifications are included in national standards to protect network integrity and ensure downstream combustion safety. For example, the concentrations of water and hydrocarbon are controlled to prevent pipeline and valve blockages, toxic components such as hydrogen sulphide and mercury are controlled on health and safety grounds, whilst hydrocarbons and liquid contaminants are managed to ensure equipment performance and safety.

National gas regulators develop and review their respective optimum specifications according to local supply sources and needs. Countries such as UK, Europe, UAE, Korea, Japan and New Zealand have gone through the review process in the light of potential new or increasingly diverse gas quality supplies.

National gas quality specifications define gas quality limits to protect the integrity of the network and ensure that gas supplied to domestic users will combust safely. They specify the gas allowed in a network and are included in commercial gas trading contracts for energy accounting, and to ensure that the gas purchased is suitable for the network. Whilst the calorific value range may be inferred by the interchangeability limits imposed, it is generally not part of a gas quality specification as Calorific Value is a commercial, energy accounting issue, rather than a quality issue. Gas quality specifications may include limits for:

- Interchangeability limits: Wobbe Index, Weaver flame speed, AGA Index, Incomplete Combustion Factor, Sooting Index.
- Hydrocarbon and water dewpoint.
- Solid and liquid contaminants.
- Hydrogen sulphide and total sulphur.
- Carbon dioxide, nitrogen and total inerts.
- Oxygen and hydrogen.
- Concentration for specified hydrocarbons.
- Contaminants, mercury, arsenic, helium, argon, chlorides, metals.
- Odour.

**Table 3.4** – Summary of UK Gas Safety (Management) Regulation, 1995.

Property	Range or Limit
Hydrogen Sulfide	< 5 mg/m <sup>3</sup>
Total sulphur	< 50 mg/m <sup>3</sup>
Hydrogen	< 0.1 mol%
Oxygen	< 0.2 mol%
Impurities and water and hydrocarbon dew points	The gas shall not contain solids or liquids that may interfere with the integrity or operation of the network or appliances
Wobbe Index	Between 47.20 - 51.41 MJ/m <sup>3</sup> – normal limits. Between 46.50 - 52.85 MJ/m <sup>3</sup> – emergency limits
Incomplete	< 0.48 – normal conditions
Combustion Factor	< 1.49 – emergency conditions
Sooting Index	< 0.60
Odour	Gas below 7 bar (g) will have a stenching agent added to give a distinctive odour

#### Impurities

Specifications are normally prescriptive on concentrations for impurities, such as maximum values for oxygen, total sulphur and hydrogen sulphide and maximum values for dew points of water and hydrocarbons. A limited number of countries have introduced specifications for maximum hydrogen content.

These impurity specifications are necessary for protection of pipeline systems and/or customer facilities from corrosion and mechanical or other damage. Often, gas quality specifications also include a general “impurity clause” aimed at proscribing (trace) components which are not monitored but could, if present in the gas, cause operational and/or other problems to the end-user.

#### Added agents

Substances may be added to the gas to protect the pipe work or instrumentation on the network. Cast iron pipes are jointed with lead and yarn that is kept swollen to maintain the seal by adding ethylene glycol. Mechanical or rubber joints are kept swollen by injecting distillate into the gas flow. With the emergence of poly-ethylene pipe the need for such additives is steadily reducing. Other additives include valve-flush agents that are used during maintenance procedures.

**Table 3.5 – Gas Specification Parameters and Operational Issues.**

Gas Constituent	Description	Issues
<b>Hydrocarbons</b>	<ul style="list-style-type: none"> <li>Provide the calorific value of natural gas when it is burnt.</li> <li>The most abundant hydrocarbon is methane but other hydrocarbons are found in decreasing concentrations as the number of carbon atoms in the hydrocarbon molecules (or carbon number) increases.</li> <li>Hydrocarbon liquids, a hydrocarbon-rich liquid phase, form via condensation from the gas phase.</li> </ul>	<ul style="list-style-type: none"> <li>Heavier hydrocarbons could form liquid phases in the network, causing blockage problems.</li> <li>The control of hydrocarbon dewpoint is the preferred method for controlling liquid formation. The specification normally reflects the expected ambient temperature and hence risk of hydrocarbon drop-out occurring.</li> </ul>
<b>Diluents or Inert Gases</b>	<ul style="list-style-type: none"> <li>Typical inert gases are carbon dioxide, nitrogen, helium and argon.</li> <li>They are non-combustible and are normally present in relatively small amounts. Both carbon dioxide and nitrogen can be used to lower the calorific value of a gas.</li> </ul>	<ul style="list-style-type: none"> <li>Very low Wobbe Index if a large amount of inert gases is present in the fuel, affecting the combustion efficiency.</li> </ul>
<b>Contaminants</b>	<ul style="list-style-type: none"> <li>Usually present in very low concentrations but they may affect downstream operations.</li> <li>Health and safety implications if the public are exposed to either the contaminants or their combustion products.</li> </ul>	<ul style="list-style-type: none"> <li>May cause corrosion of the pipeline network and restrict the gas flow.</li> <li>Turbines are particularly sensitive to impurities as the gas is burnt at very high temperatures. Under these conditions metal impurities, such as mercury, may form amalgams with the engine components, causing embrittlement, cracking and premature failure.</li> </ul>
<b>Water</b>	<ul style="list-style-type: none"> <li>The amount of water in the gas may be expressed either on a molar basis, or, more usefully, as a dew temperature at which a water-rich liquid-phase forms.</li> <li>Hydrates are ice-like solids containing hydrocarbons, and can form if the temperature of the gas decreases (at a pressure-reduction station, for example).</li> <li>The temperature, pressure and composition of natural gas in the transmission pipeline are controlled to prevent the formation of water droplets and hydrates.</li> </ul>	<ul style="list-style-type: none"> <li>The presence of excessive water in natural gas can cause corrosion of the pipeline.</li> <li>Hydrate formation can block valves and, in extreme cases, the pipeline itself.</li> </ul>
<b>Oxygen</b>	<ul style="list-style-type: none"> <li>Oxygen is strictly controlled in the UK to protect molecular sieves at LNG storage sites.</li> <li>The allowable oxygen concentration in natural gas limits the usage of air ballasting for gas quality enrichment. Compared to membrane separation, cryogenic separation is often preferred to produce high purity nitrogen for ballasting to avoid excess oxygen in ballasted gas.</li> <li>Conversely in those countries that have biogas entry points, for example Germany, a high limit of typically 3% is specified.</li> </ul>	<ul style="list-style-type: none"> <li>Can promote pipeline corrosion in the presence of water and sulphur.</li> <li>In underground storage sites, oxygen promotes bacterial activity which produces hydrogen sulphide.</li> </ul>
<b>Hydrogen</b>	<ul style="list-style-type: none"> <li>Hydrogen is flammable and in the UK can be tolerated by most domestic appliances up to about 4 mol%.</li> </ul>	<ul style="list-style-type: none"> <li>Associated with stress corrosion cracking of steel pipelines.</li> </ul>
<b>Hydrogen Sulphide</b>	<ul style="list-style-type: none"> <li>Hydrogen sulphide is toxic and it is controlled on health and safety grounds.</li> <li>Iron sulphide occurs as a result of the reaction of hydrogen sulphide with iron oxide, created by the corrosion of ferrous metals. The solid, often black in colour, can spontaneously ignite when exposed to air.</li> </ul>	<ul style="list-style-type: none"> <li>Hydrogen sulphide reacts with copper piping commonly used in domestic systems to form copper sulphide flakes which form a black dust and may cause blockage of filters and burner jets if it is allowed to accumulate.</li> </ul>
<b>Organic Sulfur Species</b>	<ul style="list-style-type: none"> <li>Organic sulphur compounds are mercaptans (also known as thiols) and sulphides that may be present naturally in the gas.</li> </ul>	<ul style="list-style-type: none"> <li>Limited due to highly unpleasant odour.</li> <li>Also to reduce the possible masking effect they may have on odorants added to the gas to aid public detection of gas leaks.</li> </ul>
<b>Solids or Liquids</b>	<ul style="list-style-type: none"> <li>Generally only introduced into the network by operational failures.</li> <li>Most regulations state that the natural gas must be commercially free of materials or dust and other solid and liquid matter so as not to interfere with the integrity or operation of the network or gas-burning appliances.</li> </ul>	<ul style="list-style-type: none"> <li>Can cause corrosion, stress or abrasion damage on pipeline and restrict the gas flow.</li> <li>Have the potential to cause severe damage to turbine meter blades.</li> <li>Liquids can block filters and the impulse lines of pressure measuring equipment. Build-up of liquid on either side of an orifice-plate meter will cause serious under-registration of the metered volume.</li> </ul>

Table 3.6 provides details of some of the existing Gas Quality specifications worldwide with the exception of Singapore and UAE where the limits are those for new or proposed gas networks.

In general the specifications are consistent in approach and the prescriptive parameters, with the exception of Wobbe Index, are similar. Where non-prescriptive parameters are included, particularly items such as dust and liquids, then similar phrasing is adopted.

The current proposed EASEE – Gas specifications have been included for reference.



**Table 3.6 – Worldwide Gas Quality Specification.**

Country	Type of Specification	Code or Rule	Governing Body	Calorific Value	Wobbe Number Interchangeability Parameter	Relative Density	H <sub>2</sub> S
UK	Safety Legislation	Gas Safety (Management) Regulations 1996	Health and Safety Executive		46.5 - 52.85 MJ/m <sup>3</sup> at 15°C; V (15°C: 1.01325 bar), ICF <0.48, SI <0.60		< 5mg/m <sup>3</sup>
	Contractual	Typical values	Bylaw/Arretes Ministeriels		47.2 to 51.4 MJ/m <sup>3</sup> at 15°C; V (15°C: 1.01325 bar), ICF <0.48, SI <0.60		< 5mg/m <sup>3</sup>
France	Regulations			Type L 34.2 - 37.8 MJ/m <sup>3</sup> at 0/0°C 101.325 kPa	Type H: 13.64 - 15.7 kWh/m <sup>3</sup> at 25°C combustion	0.555-0.7	<15 mg/m <sup>3</sup> at any time, <12mg/m <sup>3</sup> up to 8 hrs and < 7 mg/m <sup>3</sup> on average
				Type H 38.52 - 46.08 at 0/0°C 101.325 kPa			
	Transmission Limits/Contractual		Transport Company	Type H 10.7 - 12.8 kWh/m <sup>3</sup> at 25°C combustion			(H <sub>2</sub> S + COS) < 5 mg/m <sup>3</sup>
Germany	National Regulations	DVGW Coe of Practice G 260	DVGW	30.2 - 47.2 at 0°C 1.0325 bar	Group L 37.8 - 46.8 MJ/m <sup>3</sup>	0.55 - 0.75	< 5 mg/m <sup>3</sup>
					Group H 46.1 - 56.5 MJ/m <sup>3</sup>		
Italy	Transmission System	National Legislation	SNAM Rete gas	34.95 - 45.28 at 15°C 1.01325 bar	47.31 - 52.33	0.5548 - 0.8	< 6.6 mg/m <sup>3</sup>
Poland	Transmission System Specification	IRIESP Rule	GAZ SYSTEM	25°C combustion, 0°C metering, 1013.25 bar, ranges not specified.	45 - 54		7 mg/m <sup>3</sup>
					37.5 - 45		< 5 mg/m <sup>3</sup>
					32.5 - 37.5		< 5 mg/m <sup>3</sup>
Norway	Transmission System Specification	Terms & Conditions for transportation of gas	Ministry of Petroleum and Energy	38.1 - 43.7 MJ/m <sup>3</sup> , 25°C; V (15°C: 1.01325 bar)	48.3 - 52.8 MJ/m <sup>3</sup> 25°C; V (15°C: 1.01325 bar)		H <sub>2</sub> S + COS as sulphur
Netherlands	Entry Gas Specification		Gas Transport Services	Specific ranges between 31.0 - 35.0 MJ/m <sup>3</sup>	Specific ranges between 43.4 - 56.7 MJ/m <sup>3</sup>		< 5 mg/m <sup>3</sup>
			Gas Transport Services	Utility Sector 31.6 - 38.7 MJ/m <sup>3</sup>	Utility Sector 42.7 - 45.2 MJ/m <sup>3</sup>		
	Exit Gas Specification		Gas Transport Services	Industrial G-gas 31.6 - 38.7 MJ/m <sup>3</sup>	Industrial G-gas 42.7 - 47.11 MJ/m <sup>3</sup>		< 5 mg/m <sup>3</sup>
			Gas Transport Services	Industrial H-gas 35 - 47 MJ/m <sup>3</sup>	Industrial H-gas 47 - 57.5 MJ/m <sup>3</sup>		
Spain	Transmission System Specification	BOE, April 4 2006	System Technical Manager	36.83 - 44.03 MJ/m <sup>3</sup> at 25°C; (0°C: 1,01325 bar)	48.13 - 57.60 MJ/m <sup>3</sup> at 25°C; (0°C: 1.01325 bar)		
Denmark	National Safety Regulation	Danish Gas Codes	Danish Safety Technology Authority	Range not specified	51.9 - 55.8 MJ/m <sup>3</sup> , under extreme supply conditions up to 56.5 MJ/m <sup>3</sup>	0.555 - 0.7000	< 5 mg/m <sup>3</sup>
	Transmission System Specification	Rules for Gas Transport	Energinet.dk (the Danish TSO)	39.6 - 46.0 MJ/m <sup>3</sup> (gross dry at 25°C/0°C, 1.01325 bar) under extreme supply conditions up to 46.8 MJ/m <sup>3</sup>	50.8 - 55.8 MJ/m <sup>3</sup> , under extreme supply conditions up to 56.5 MJ/m <sup>3</sup>	<0.7	H <sub>2</sub> S+COS < 5 mg/m <sup>3</sup> as sulphur
Switzerland	National Regulations	G 2007 / 1	SVGW	Hs,n 11.4 kWh/Nm <sup>3</sup> (Hi,n 10.3 kWh/m <sup>3</sup> ) at 0°C 1013.25 mbar	Ws,n 14.5 kWh/m <sup>3</sup>	0.61-0.69	
EASEE-gas	EU Proposed	Common Business Practice 2005-001/01 Harmonisation of Gas Qualities			48.32 to 54.0 MJ/m <sup>3</sup> at 15°C; V (15°C: 1.01325 bar)	0.62	H <sub>2</sub> S+COS < 5 mg/m <sup>3</sup> as sulphur
Brazil	Technical Regulation		North	34 - 38.4 MJ/m <sup>3</sup> , dry gas at 20°C, 101.325 kPa	40.5 - 45 MJ/m <sup>3</sup>		10.0 mg/m <sup>3</sup>
			Northeast	35 - 42 MJ/m <sup>3</sup> , dry gas at 20°C, 101.325 kPa	46.5 - 52.5 MJ/m <sup>3</sup>		15.0 mg/m <sup>3</sup>
			South, Southeast, Centre, West				10.0 mg/m <sup>3</sup>
NZ		NZS 5442:1999	Standards Council/Ministry of Energy	35.2 - 46.5 MJ/m <sup>3</sup> at 15°C, 101.325 kPa (implied)	46 - 52 MJ/m <sup>3</sup>	<0.8	< 5mg/m <sup>3</sup>
UAE	ADNOC Distribution	Proposed Specification July 2007 for upgrade from LPG supply to PNG		36.9 - 42.3 MJ/m <sup>3</sup>	48.2 - 51.2 MJ/m <sup>3</sup>	0.5548-0.7	< 3.3ppm (by volume)



Table 3.6 – Continued.

Total Sulfur	O <sub>2</sub> / H <sub>2</sub>	Inerts (N <sub>2</sub> , CO <sub>2</sub> )	Impurities	Hydrocarbon & Water Content	Odour	Temp
< 50 mg/m <sup>3</sup>	O <sub>2</sub> < 0.2%, H <sub>2</sub> < 0.1 mol%	n/a	Must not contain solids or liquids that may interfere with integrity of network or appliances	Such that liquids do not interfere with integrity of network or appliances	Gas below 7 barg will have tenching agent added	n/a
< 50 mg/m <sup>3</sup>	O <sub>2</sub> < 0.001 mol%, H <sub>2</sub> < 0.1 mol%	< 2.5%	Must not contain solids or liquids that may interfere with integrity of network or appliances. Organo halides < 1.5mg/m <sup>3</sup> . Radioactivity < 5 Becquerels/g	HC dew < -2°C, water dew < -10°C at any pressure upto 85 bar	No odour that might contravene the statutory requirement	1 - 38°C
< 150 mg/m <sup>3</sup>				Water dew < -5°C at maximum operating pressure	Transmission must supply odourised gas to industrial users and distribution companies (Law 2004-251 March 2004)	
< 30 mg/m <sup>3</sup>					Distributed gas must have odour for leak detection (Law enacted July 2000)	
< 30 mg/m <sup>3</sup>	O <sub>2</sub> < 100 ppm, H <sub>2</sub> < 6% (biogas)	< 2.5%	Mercury < 1mg/m <sup>3</sup>	Water dew < -5°C, HC dew < -2°C between 1 - 70 bar	< 40mg equivalent of THT/m <sup>3</sup>	0 - 60°C
< 150 mg/m <sup>3</sup>	O <sub>2</sub> < 3% (dry gas), H <sub>2</sub> < 5% (biogas injection)	< 6% (biogas injection)	Technically free of mist, dust, liquid	Ground temp at pipeline pressure	Gas must have a "warning smell" at distribution level	
40 mg/m <sup>3</sup>	O <sub>2</sub> < 0.6 mol%					
	O <sub>2</sub> < 0.2	< 3 mol%	Free of liquid HC's or water and no solids or gases that could damage system		Must be odourised for domestic customers	Max 50°C
	O <sub>2</sub> < 2 ppm vol	3	Dust particles < 5 microns and < 1 mg/m <sup>3</sup> . Mercury < 30 mg/m <sup>3</sup>	HC dew < 0°C between 1 - 70 bar, water dew < -5°C at 55bar winter, < 3.7°C at 55 bar summer	No odour that might contravene the statutory requirement	
	O <sub>2</sub> : Specific to entry point, between 0.0005 - 0.5 vol%					
	O <sub>2</sub> < 0.5 vol%					
< 30 mg/m <sup>3</sup>	O <sub>2</sub> < 0.01 mol %	< 2.5 mol %		Entry points: HC dew < -10°C at 51 bar(a), water dew < -18°C at 70 bar(a), Exit points: HC dew < -3°C at 1-70 bar (a), water dew < -12°C at 70 bar(a)		
< 20 mg/m <sup>3</sup>	O <sub>2</sub> < 0.1%	Specific to entry point, 1.5 - 8.0 vol%		Water dew < -8°C at delivery pressure, HC dew < 5 mg/m <sup>3</sup> at -3°C at delivery pressure		0 - 50°C
45 mg/m <sup>3</sup>		8 vol%		Water dew < -8°C at delivery pressure, HC dew: technically free of condensate		-10 - 40°C
45 mg/m <sup>3</sup>	O <sub>2</sub> < 0.01 mol%	8 vol%		Water dew < -8°C at delivery pressure, HC dew: technically free of condensate		
150 mg/m <sup>3</sup>		3 vol%		Water dew < -8°C at delivery pressure, HC dew < 5 mg/m <sup>3</sup> at -3°C at delivery pressure		
< 50 mg/m <sup>3</sup>		< 2.5 mol %	W not contain solids or liquids	HC dew < 5°C at 1-70 bar(a), water dew 2°C at 70 bar(a)	22mg of THT/m <sup>3</sup> gas at Metering Regulation Station	
Other sulphur components < 10 mg/m <sup>3</sup>			Must not contain solids or liquids that may interfere with integrity of network or appliances	HC dew < -5°C at 0 - 4 bar, water dew < 0°C at operating pressure	Gas in distribution systems must be detectable at 20% of LEL. THT concentration at delivery points must be at > 10.5 mg/m <sup>3</sup>	
< 30 mg/m <sup>3</sup>		< 2.5%		HC dew < -2°C at any pressure up to 70 bar, water dew < -8°C at any pressure up to 70 bar	In the transmission system the gas must be without added odour	0 - 50°C
8 mg/m <sup>3</sup>				C <sub>2</sub> - C <sub>6</sub> 6.2 (% Vol)		
< 30 mg/m <sup>3</sup>		< 2.5 mol%		Water dew < -8°C at 70 barg, HC dew < -2°C at 1 - 70 bar		
< 70 mg/m <sup>3</sup>	O <sub>2</sub> < 0.8 %vol		Gas must not contain visible solid or liquid particles	Water dew < -39°C at 1 atp		
	O <sub>2</sub> < 0.5 %vol			Water dew < -45°C at 1 atp		
< 50 mg/m <sup>3</sup> (incl odorant)	O <sub>2</sub> < 1.0 med & low pressure, < 0.1% other cases, H <sub>2</sub> < 0.1%			Water content 100 mg/m <sup>3</sup> , HC dew < 2°C at 5 Mpa		2 - 40°C
< 15 - 35ppm (by volume) < 30 mg/m <sup>3</sup>	O <sub>2</sub> < 10 ppm	< 4.0% (< 5% N <sub>2</sub> , total inerts < 7%)	Free of dust and liquids. Particles < 2 micron	Water dew < -10°C at 69 bar(g), HC dew < -2°C at any pressure up to 69 bar(g)	No objectional odor. Gas below 16 bar will have standing agent added	

**Table 3.6 – Continued.**

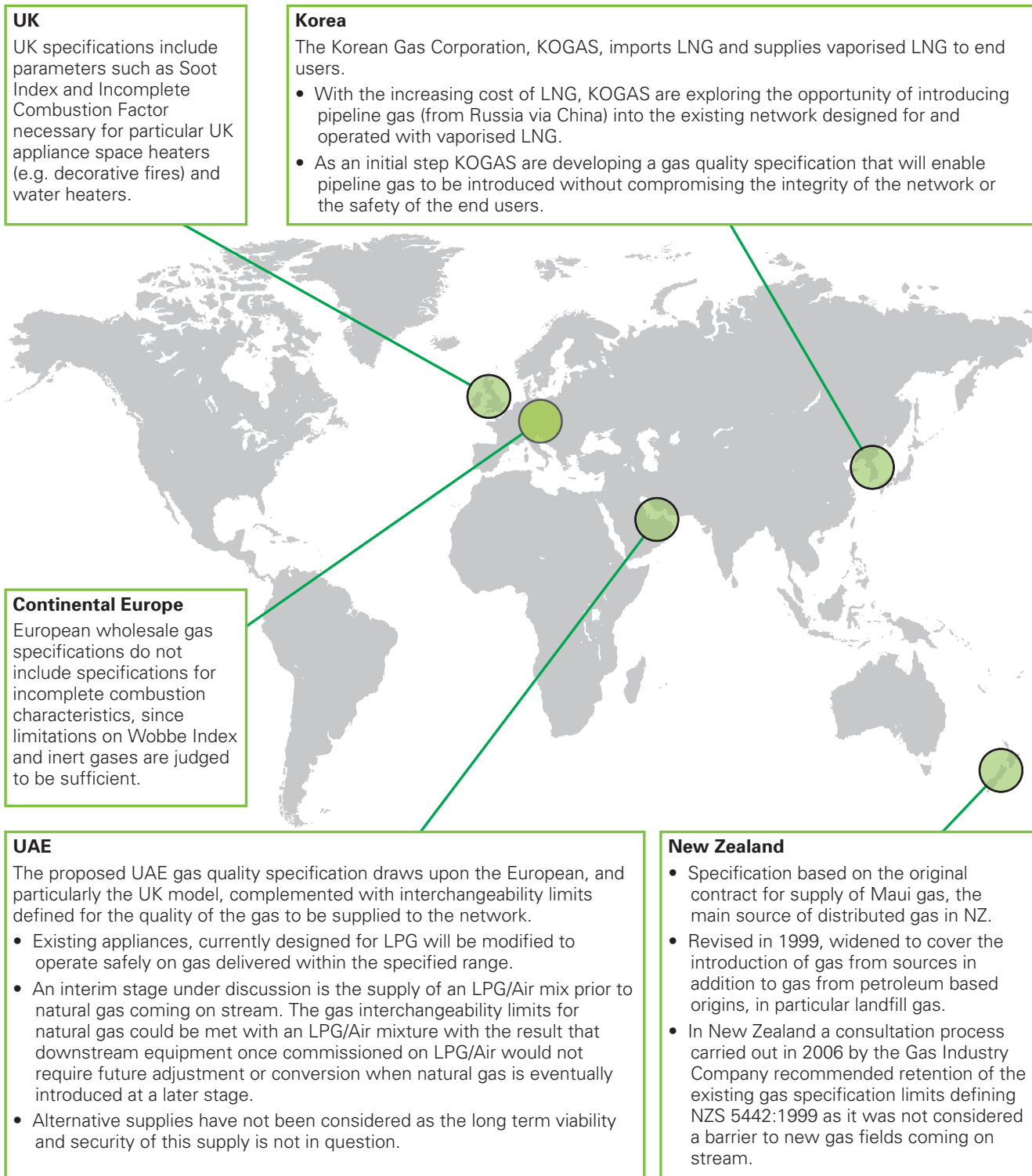
Country	Type of Specification	Code or Rule	Governing Body	Calorific Value	Wobbe Number / Interchangeability Parameter	Relative Density
<b>Singapore</b>	Proposed specification of PNG replacing Towns Gas	Common Gas Specification		35.3 - 50.3 MJ/m <sup>3</sup>	45.2 - 52.0 MJ/m <sup>3</sup>	
<b>Israel</b>					48.7-53.7 MJ/m <sup>3</sup>	
<b>USA</b>	Generic - Interstate Tariffs		Transmission Pipeline Company	> 950 Btu per ft <sup>3</sup>		
	PG&E Rule 21			As per established standards at Reception Points	Must comply with interchangeability limits stated in AGA Bulletin 36	
	SoCalGas Rule 30			970 - 1150 Btu	Must comply with AGA limits for WI, Lift Index, Flashback and yellowtip	
	MarkWest New Mexico		FERC Gas Tariff	> 950 Btu/ft		
	Gulfstream Natural Gas System		FERC Gas Tariff			
	Black Martin Pipeline Company		FERC Gas Tariff			
	Northern Natural Gas Company	Proposed 31.05.2007	FERC Gas Tariff		1,245 - 1,365	
<b>Canada</b>		General Terms and Conditions of the Transportation Agreement	TransCanada		< 52.14	
<b>China</b>	Transmission and Distribution	GB 17820-1999	National Standard	> 31.4 MJ/m <sup>3</sup> @ 20 °C, 101.325 kPa, Gross		
<b>Mexico</b>	Federal		Energy Regulatory Commission	35.42 - 41.53 MJ/m <sup>3</sup> real gross dry @ 20/20 °C, 101.33 kPa	45.8 - 50.6 @ 20/20 °C, 101.33 kPa	
<b>Korea</b>	LNG Import Specification			41.35 to 46.47 MJ/m <sup>3</sup> real gas @ 15°C, V(0°C, 101.325kPa)		
	Domestic Gas Supply			43.54 MJ/Nm <sup>3</sup> tandard Heating Value. Lowest 42.28 MJ/Nm <sup>3</sup>	52.75 to 57.78 MJ/Nm <sup>3</sup>	
<b>Japan</b>	Distribution		Tokyo gas	45 MJ/m <sup>3</sup> +/- 1 MJ		
<b>EASEE - Gas (Proposed)</b>	Gas trading across Europe				47.0 - 54.0 MJ/m <sup>3</sup>	0.5548 - 0.7

Table 3.6 – Continued.

H <sub>2</sub> S	Total Sulfur	O <sub>2</sub> / H <sub>2</sub>	Inerts (N <sub>2</sub> , CO <sub>2</sub> )	Impurities	Hydrocarbon & Water Content	Odour	Temp
< 8 ppm by volume	< 30 ppm by volume	O <sub>2</sub> < 0.1% vol	< 5 %vol (< 5% N <sub>2</sub> , total inerts < 10%)	No free liquids, particulate < 10 micron and < 3 ppm by weight. Lead < 1ppm, potassium and sodium 0.5ppm, magnesium 2ppm all by weight	Water dew < 9.4°C at 50 bar, HC dew < 12.8°C at 50 bar		
< 8ppm	< 150 ppm (as H <sub>2</sub> S)	O <sub>2</sub> < 0.1ppm		Free from odours, materials, dust or other solid or fluid matters. Waxes, gums and gum forming constituents		Free from odours	
< 0.25 grain per 100 scf	< 20 grains per 1,000 cft	O <sub>2</sub> < 1%vol or < 0.2%vol	CO <sub>2</sub> < 2%, N <sub>2</sub> < 3%, Total inerts < 4%	No free liquids Commercially free of solids. Free of toxic or hazardous substances	Water content < 7 lbs water vapour per 1,000 Mcf		< 120 °F
< 0.25 grain per 100 scf	< 1.0 grain per 100 scf	O <sub>2</sub> < 0.1%	CO <sub>2</sub> < 3%	No liquids at reception points, no dust, sand gums or oils or other material	Water content < 7 lbs / 1,000,000 scf, HC no formation in receiving pipeline		60 - 100°F
< 0.25 grain per 100 scf	< 0.75 grain per 100 scf	O <sub>2</sub> < 0.2%	CO <sub>2</sub> < 1% (Total inerts < 4%)	Commercially free of dust, gums and other foreign matter	Water content < 7 lbs/1,000,000 scf for gas del. below 800psig, < 20 °C for gas del. above 800 psig. HC dew < 45°F @ 400 psig for gas del. below 800psig, < 20°F @ 400psig for gas del. above 800 psig		50 - 105°F
< 0.25 grain per Ccf	< 0.20 grain per Ccf	O <sub>2</sub> < 0.2%vol	CO <sub>2</sub> < 2.0 %vol	Commercially free of objectional odours, solid matter, dust and gum-forming constituents or any substance that might interfere with the merchantability of the gas	Water content < 6 lbs/MMcf		> 120°F
< 4 ppm (0.25grain per 100cft)	< 10 grain per 100cft	O <sub>2</sub> < 0.25 %vol	< 3 %vol of CO <sub>2</sub> + N <sub>2</sub>	Shall not contain any free water. Gas will not contain any toxic, hazardous material or substances, or any deleterious material potentially harmful to persons or the environment (including PCBs) and substances requiring investigation, remediation or removal under law.	Water content < 7 lbs water per million cft		40 - 120°F
< 0.25 grain per 100 cft	< 10 grain per 100 cft	O <sub>2</sub> < 0.2 %vol	< 3 %vol CO <sub>2</sub> + N <sub>2</sub>	Gas shall be free of objectional odours, solid matter, dust and gum-forming constituents or any substance that might interfere with the merchantability of the gas	Water content < 7 lbs water vapour per 1,000 Mcf		> 120°F
		O <sub>2</sub> < 10 ppm per 0.001 %vol	CO <sub>2</sub> < 2 %vol, Total inerts > 3% and < 4%	Gas will not contain any toxic, hazardous material .....	Cricodentherm HC dew < -5°F, assuming C <sub>6</sub> + is 48% C <sub>6</sub> , 35% C <sub>7</sub> , 15% C <sub>8</sub> and 2% C <sub>9</sub> < 1.5% C <sub>10</sub> +		> 35 °F
< 23 mg/m <sup>3</sup> (16ppm)	115 mg/m <sup>3</sup>	O <sub>2</sub> < 0.4 %vol	CO <sub>2</sub> < 2 %vol, Total inerts < 4 %vol	Gas shall be free of objectionable material.	Water content < 65 mg/m <sup>3</sup> , HC dew < -10°C @ 5,500 kPa < 1.5% C <sub>4</sub> +		> 50°C
Type 1 - Domestic supply < 6 mg/m <sup>3</sup> (where wet gas due to storage holders)	Type 1 - domestic supply < 100mg/m <sup>3</sup>						
Type 2 - Domestic supply < 20 mg/m <sup>3</sup>	Type 2 - Domestic supply < 200 mg/m <sup>3</sup>		CO <sub>2</sub> < 3.0 %vol	No water or hydrocarbon liquids, no particles that might affect transmission, distribution or end user.	Water dew must be at least 5°C below the lowest surrounding ambient temperature	Gas supplied to domestic users must be odourised so it can be detected in air at 20% of the LEL	
Type 3 - Industrial supply < 460 mg/m <sup>3</sup>	Type 3 - Industrial supply < 460mg/m <sup>3</sup>		-				
< 6.1mg/m <sup>3</sup>	150 mg/m <sup>3</sup>	O <sub>2</sub> < 0.2 mol%	CO <sub>2</sub> < 3%vol, N <sub>2</sub> < 5%vol, Total inerts < 5 %vol	Free from dusts, rubbers and any solid that may cause problems in the pipelines and their installations. Free from liquids	Water content < 112 mg/m <sup>3</sup> , HC dew < -2 °C at 0 - 8000 kPa		10 - 50°C
< 0.25 grains per 100Scf	< 2 grains per 100 Scf		N <sub>2</sub> < 1.0 mol%		C <sub>1</sub> > 85 mol%, C <sub>4</sub> + < 2.0 mol%, C <sub>5</sub> + < 0.25%		
< 6 mg/m <sup>3</sup>	< 31.4 mg/m <sup>3</sup>		N <sub>2</sub> < 1.0%		Not less than 85 mol% C <sub>1</sub> .		0 - 20°C
	< 30 mg/m <sup>3</sup>	O <sub>2</sub> < 0.01 mol%	CO <sub>2</sub> < 2.5 mol%		water dew < -8°C, HC dew < -2°C at any pressure below 69 barg		

Gas quality specifications may act as a barrier to commercial operations and a block to the use of increasingly diverse gas supplies. It is important to regularly review such specifications to ensure they do not restrict trade whilst maintaining the safety of the public.

New gas networks present the opportunity to prepare the broadest gas quality specification compatible with the range of combustion equipment installed. The following are examples to demonstrate how gas quality specifications have been reviewed or developed in the light of potential new or increasingly diverse gas quality supplies.



**Figure 3.3** – Development of Gas Quality Specifications.

### Case Study 3.1 Gas Quality Management in Japan

During 2004 Japan imported 58 million tones of LNG accounting for 48% of the global LNG transactions. A third of the LNG is used for domestic purposes with the balance used for power generation. Vaporised LNG is distributed by more than 200 local distribution companies (LDCs).

#### Tokyo Gas

Tokyo Gas vaporises stored LNG in accordance with the demand, and injects LPG so that the heating value is almost constant. Stored LNG varies from 40 - 45 MJ/m<sup>3</sup> and is enriched to the "standard heating value" of 45 MJ/m<sup>3</sup> ± 1 MJ/m<sup>3</sup>. The alternative of ballasting the vaporised LNG to the lower heating value was more expensive. Industrial and commercial gas appliances, including gas engines and turbines, have been optimised to achieve high efficiency and low emissions at the standard heating value.

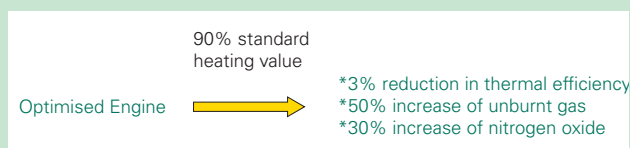


Figure 3.4 – Impact of Gas Quality in Combustion.

Providing gas with a constant heating value negates the need for end users to invest in expensive control systems and allows operators of combustion critical industries, for example glass manufacture, to maintain product quality.

#### Osaka Gas

In order to reduce enrichment costs and to accommodate increasingly diverse LNG cargoes, Osaka Gas proposed to supply gas having a range of heating values. To ensure end users maintained efficiency and low emissions Osaka Gas detuned users' appliances to operate over the defined range, and installed a rapid response gas quality measuring system, GasPT™, in feed-forward control systems on gas fired engines with no detectable loss of efficiency.

### 3.4.2 Odourisation and Operational Safety

**Odorants are added to enable the detection of odourless natural gas by end-users in case of leakage. This normally happens at City Gate stations. Various odorants such as mercaptan, sulphide and tetrahydrothiophene (THT) based compounds at different concentrations are used.**

After the extraction and purification processes have been carried out, natural gas usually has no smell, colour or taste and is therefore undetectable by human beings. National gas quality specifications require distributed gas to have a distinctive odour to enable gas leaks to be detected by the general public. Odourisation, which may be carried out at the entry to the Transportation system or more commonly at city gates, imparts a distinctive odour to the gas that is easily detectable by humans. The presence of odorant means that natural gas can be smelt in air at concentrations very much lower than the Lower Explosive Limit (LEL), this aids leak detection, and helps to reduce the risk of explosions due to gas leaks.

Different systems choose either to odorise the high pressure system or to convey unodorised gas in the high pressure system and add odorant at the point of entry into lower pressure networks. Given increased bidirectionality of gas flows, this can now cause difficulty when commercial flows suggest gas should move from an odorised network into a deodorised network. This can require additional costs either to remove odorant, or to shift points of odorisation in the latter system downstream.

Mercaptan or mercaptan/sulphide (RSH) odorant blends are used in the UK and in parts of Germany, Italy and Belgium. The majority of Europe uses tetrahydrothiophene (THT) based odorants. To meet the growing demand for sulphur free odorants an acrylate based odorant known as S-Free™ was developed by Ruhr Gas however it has achieved limited market penetration.

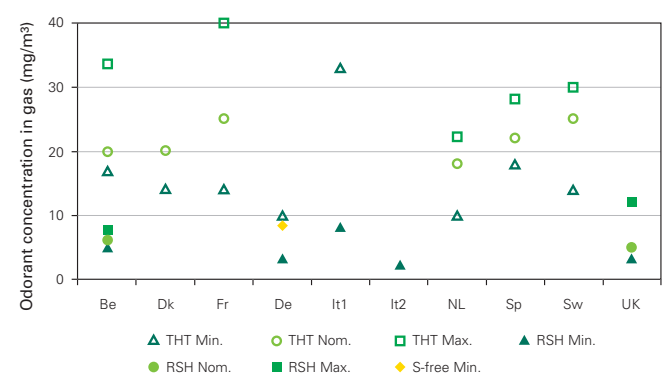


Figure 3.5 – Odorants Used Across Europe.

## 3.5 Country Initiatives

In the remainder of this chapter of the Guidebook we will examine the recent and future convergence of international definitions and standards on gas interchangeability, which will benefit gas producers, shippers, transporters, suppliers and consumers alike, by ensuring that natural gas is traded consistently in terms of quality and energy content.

### There are many initiatives underway to update or redefine national gas quality standards.

Country regulators are moving towards a common understanding of the most appropriate definitions and parameters to use within gas trading contracts as natural gas moves across international boundaries and between gas transporters.

#### 3.5.1 Mainland Europe, UK and USA Initiatives

**In Europe, a harmonised gas quality specification, EASEE-gas, has been proposed to create a fully operational European internal market, with minimum operational requirements to ensure interoperability of systems. A two-stage approach and appliance testing is planned to produce a harmonised standard within Europe.**

**In the UK, it is concluded that all import gases have to be processed to meet the GS(M)R requirements. Risks for gas prices and security of supply are deemed to be too small to mandate conversion of all downstream equipment to meet new gas quality specifications.**

**Wobbe Index is accepted as the primary interchangeability parameter in the USA. A  $\pm 4\%$  Wobbe Index band is recommended by the NGC+ (a workgroup formed by the Natural Gas Council) with an additional High Heating Value limit of 1110 Btu/scf.**

#### UK

We have seen in Chapter 2 the UK gas interchangeability diagram with the UK GS(M)R setting the limits of Wobbe Index at between 47.20 - 51.41 MJ/m<sup>3</sup> with further boundaries set by the Incomplete Combustion Factor and Sooting Index. The UK Government, led by the Department of Trade and Industry (DTI, now the Department of Energy and Climate Change, DECC), has completed a Gas Quality Programme including studies to review gas supply options, gas processing alternatives, an appliance survey and an appliance test programme to quantify the effects of gas quality changes on emissions and efficiency.

In November 2007 the UK government issued its conclusions in response to the public consultation on the future arrangements for Great Britain's gas quality specifications:

- The conclusion is a 'no change' option for gas quality specification.
- The cost of adjustment, conversion or buy-out of some 45 million appliances in 22 million premises was between £2 - 14 billion.
- The risks for gas prices and security of supply are judged to be small.

The conclusion is therefore that imported gas from pipeline interconnectors or LNG shipments will have to be processed to meet the existing UK GS(M)R specification. In the case of LNG imports this will probably involve nitrogen ballasting to lower the Wobbe Index to within the limits.

#### Europe

The European internal market for natural gas is opening up through EC Directive 2009/73/EC with the objective to create a fully operational internal gas market in which fair competition prevails. National differences in gas quality specifications have been seen as a barrier to cross-border trade and EASEE-gas (via European Regulatory Forum) have proposed a harmonised gas quality specification across Europe.

The primary interchangeability parameter is Wobbe Index between 13.60 - 15.81 kWh/m<sup>3</sup> (cf. UK 13.82 kWh/m<sup>3</sup> and 15.05 kWh/m<sup>3</sup>). EASEE-gas is also proposing the additional requirement of relative density to be limited to a maximum 0.700.

The European Commission is looking to implement the EASEE-gas CBP (Common Best Practice) on Gas Quality with "...minimum operational requirements to ensure interoperability of systems..." and it has recently placed a mandate on CEN, the European standards body, to produce a harmonised standard by 2010. CEN are adopting a two-stage approach:

- Survey/Analysis on installed gas appliance population across all 27 EU countries and a test programme for a selection of representative appliances.
- Produce a harmonised EN Standard on H (high Calorific Value) gas quality based on the results from the gas appliance test programmes.

The two-year test programme, to be started in 2008, will be similar to the work completed for the UK with mostly domestic appliances being tested at and beyond the limits of the proposed EASEE-gas specification and measuring effects on emissions, safety devices and efficiency.

<sup>2</sup> (a) "White Paper on Natural Gas Interchangeability and Non-Combustion End Use", Natural Gas Council Plus (NGC+) Interchangeability Work Group, February 2005.

<sup>2</sup> (b) Policy Statement on Provisions Governing Natural Gas Quality and Interchangeability in Interstate Natural Gas Pipeline Company Tariffs, 115 FERC 61,325 P30, 2006.

## USA

An extensive study<sup>2</sup> in the USA by the NGC+ has resulted in a White Paper to the Federal Energy Regulatory Commission recommending Wobbe Index as the primary interchangeability parameter. The study involved representatives from North American manufacturers, transporters, suppliers and consumers, together with some European input and the recommendation is for a  $\pm 4\%$  Wobbe Index band around an historical average point with an additional High Heating Value limit of 1110 Btu/scf.

New teams organised through the AGA are reviewing two important documents for the USA gas industry:

- AGA Report 4A: Natural Gas Contract Measurement and Quality Clauses.
- Research Bulletin 36: Interchangeability of Other Fuel Gases with Natural Gases.

The USA also continues to carry out appliance testing through the Gas Appliance Manufacturers Association (GAMA), Southern California Gas (SOCAL), California Energy Commission (CEC) with the use of test laboratories such as the Gas Technology Institute (GTI). In the last few years, planning submissions for numerous LNG importation terminals have resulted in Federal Energy Regulatory Commission (FERC) hearings (e.g. Florida and California) which have provided public debate on the gas quality issues.

### 3.5.2 Convergence

**Despite the improving common understanding of gas quality parameters internationally, significant efforts are still required to standardise the units and reference conditions to eliminate potential errors, especially in commercial contracts.**

**The Wobbe Index range in the proposed EASEE-gas specification is wider than many current national standards.**

#### Parameters and References

As discussed, Wobbe Number or Wobbe Index is now the industry-standard gas interchangeability parameter because it indicates the relative amount of energy flowing through a small burner/orifice jet. Other supplementary parameters such as Gross Calorific Value and Relative Density are used to limit the amount of higher hydrocarbons and inert gases.

Despite this common acceptance however, different units and reference conditions are used in various national documents (Table 3.7) leading to potential errors when a value is quoted.

**Table 3.7** – International Comparison of Wobbe Index Definition.

Country	Definition	Units	Reference temperature for: Combustion Metering	
UK GS(M)R	Gross Calorific Value (Specific Gravity) <sup>1/2</sup>	MJ/m <sup>3</sup>	15°C	15°C
US	High Heating Value (Relative Density) <sup>1/2</sup>	Btu/scf	60°F	60°F
EASEE-gas	Gross Calorific Value (Relative Density) <sup>1/2</sup>	kWh/m <sup>3</sup>	25°C	0°C

Table 3.7 shows that there is still some way to go in terms of gaining a common set of definitions across the UK, the USA and the proposed EASEE-gas specification. The UK definition and conditions as quoted in the UK Gas Safety (Management) Regulations are in line with the international standard ISO 6976 (1995) and the USA conditions follow the American standard Gas Processors Association GPA 2172-96.

All the definitions are equivalent such that the Gross Calorific Value is the same as High Heating Value but the different units and reference temperatures are a potential source of error when converting between reference conditions. It is, therefore, important to ensure that in any gas sales or purchasing contracts make it clear to which standards the gas quality parameters are being measured and calculated.

#### Wobbe Index Range

We have discussed the international initiatives being taken currently to converge on gas interchangeability limits but still recognise that different regions have designed, installed and adjusted gas-fired equipment for optimum performance on the range of gases historically seen in that region.

Table 3.8 gives a view of the current situation on acceptable Wobbe Index ranges across a number of countries. These are figures taken from national standards but some countries such as Japan will have operated well within these limits for many years, having taken long-term LNG contracts.

**Table 3.8** – International Comparison of Wobbe Index Ranges.

USA	White Paper <sup>3</sup>	$\pm 4.0\%$ Wobbe
UK	GS(M)R	$\pm 4.3\%$ Wobbe
EASEE-gas	Proposed CBP Gas Quality	$\pm 5.6\%$ Wobbe
France	Transmission Entry Spec.	$\pm 7.0\%$ Wobbe
Germany	National Standards	$\pm 10.1\%$ Wobbe
Italy	National Standards	$\pm 5.0\%$ Wobbe
Korea	National Standards	$\pm 4.6\%$ Wobbe
New Zealand	National Standards	$\pm 6.1\%$ Wobbe
UAE	Abu Dhabi Spec.	$\pm 3.0\%$ Wobbe

<sup>3</sup>J.Dweck, K.E.Gibbs & M.W.Brooks. "US Gas interchangeability Policy Ripples Through Global LNG Industry"; October – December 2006, LNG Observer

## Appendix 3.1

### International Gas Quality Standards

We can see therefore that there is international recognition that gas quality will vary more in future as different gas sources are used to provide security of supply. This will result in more consumers receiving gas which varies in Wobbe Index and that is at the limits of gas specifications, with the potential for changes occurring over short periods.

#### **ISO 6143:2001**

Gas analysis – Comparison methods for determining and checking the composition of calibration gas mixtures.

#### **ISO 6326-4:1994**

Analysis of Fuel Gases. Section 11.4.4:1994 hydrogen sulphide, carbonyl sulphide, and sulphur containing odorants by gas chromatography using a flame photometric detector.

#### **ISO 6327:1981**

Natural gas – Determination of the water dew point of natural gas – Cooled surface condensation hygrometers.

#### **ISO 6568:1981**

Natural gas – Simple analysis by gas chromatography.

#### **ISO 6570:2004**

Natural gas – Determination of potential hydrocarbon liquid content – Gravimetric methods.

#### **ISO 6578:1991**

Refrigerated hydrocarbon liquids – Static measurement – Calculation procedure.

#### **ISO 6974-1:2001**

Natural gas – Determination of composition with defined uncertainties by gas chromatography – Part 1: Guidelines for tailored analysis.

#### **ISO 6974-2:2002**

Natural gas – Determination of composition with defined uncertainties by gas chromatography – Part 2: Measuring-system characteristics and statistics for processing of data.

#### **ISO 6974-3:2001**

Natural gas – Determination of composition with defined uncertainties by gas chromatography – Part 3: Determination of hydrogen, helium, oxygen, nitrogen, carbon dioxide and hydrocarbons up to Octane using two packed columns.

#### **ISO 6974-4:2001**

Natural gas – Determination of composition with defined uncertainties by gas chromatography – Part 4: Determination of nitrogen, carbon dioxide and C1 to C5 and C6+ hydrocarbons for a laboratory and on-line measuring system using two columns.

#### **ISO 6974-5:2001**

Natural gas – Determination of composition with defined uncertainties by gas chromatography – Part 5: Determination of nitrogen, carbon dioxide and C1 to C5 and C6+ hydrocarbons for a laboratory and on-line process application using three columns.

#### **ISO 6974-6:2002**

Natural gas – Determination of composition with defined uncertainties by gas chromatography – Part 6: Determination of hydrogen, helium, oxygen, nitrogen, carbon dioxide and C1 to C8 hydrocarbons using three capillary columns.

#### **ISO 6975:2005**

Natural gas – Extended analysis – Gas-Chromatographic method.

#### **ISO 6976:1995**

Natural gas – Calculation of calorific values, density, relative density and Wobbe Index from composition.

#### **ISO 7504:2001**

Gas analysis – Vocabulary.

#### **ISO 10101-1:1998**

Natural gas – Determination of water by the Karl Fischer method – Part 1: Introduction.



**ISO 10715:2001**

Natural gas – Sampling guidelines.

**ISO 10723:2002**

Natural gas – Performance evaluation for on-line analytical systems.

**ISO 11541:2002**

Natural gas – Determination of water content at high pressure.

**ISO 12213-1:1997**

Natural gas – Calculation of compression factor  
– Part 1: Introduction and guidelines.

**ISO 12213-2:1997**

Natural gas – Calculation of compression factor  
– Part 2: Calculation using molar-composition analysis.

**ISO 12213-3:1997**

Natural gas – Calculation of compression factor  
– Part 3: Calculation using physical properties.

**ISO 13443:1995**

Natural gas- Standard reference conditions.

**ISO 13686:2005**

Natural gas – Quality designation.

**ISO 14532:2001**

Natural gas – Vocabulary.

**ISO 15972:2002**

Natural gas – Measurement of properties – Single components and condensation properties – Water content and water dew-point determination.

**ISO 16664:2004**

Gas analysis – Handling of calibration gases and gas mixtures – Guidelines.

**ISO/TS 16922:2002**

Natural gas – Guidelines for odourising gases.

**ISO 18453:2004**

Natural gas – Correlation between water content and water dew point.

**ISO FDIS 20765-1:2005**

Natural gas – Calculation of thermodynamic properties  
– Part 1: Gas phase properties for transmission and distribution applications.

**ISO DIS 23874:2005**

Natural gas – Analytical requirements for hydrocarbon content/dew point calculation.

ISO (1993) Guide to the Expression of Uncertainty in Measurement (GUM), [BSI PD 6461-3:1995 General metrology – Part 3: Guide to the expression of uncertainty in measurement (GUM)].

**United States of America**

Gas Processors Association GPA 2172-96 'Calculation of Gross Heating Value, Relative Density and Compressibility Factor for Natural Gas Mixtures for Compositional Analysis'.

American Society for Testing and Materials produce a range of standards relating to test methods for hydrocarbon analysis.

American Gas Association AGA Report 4A: Natural Gas Contract Measurement and Quality Clauses.

American Gas Association AGA Research Bulletin 36: Interchangeability of Other Fuel Gases with Natural Gases.



## Chapter 4

### LNG Production, Supply and Lifecycle

In common with pipeline natural gas, there are a number of factors which impact on the production and quality of LNG.

LNG is typically richer, or higher in Wobbe Index than pipeline gas. The variation in gas quality from different LNG sources is already significant, but as the LNG travels from production to supply point its composition changes again through a boil-off or weathering process. This means that regasified LNG can not always be accepted directly into transmission and distribution networks, and that the trading of LNG is also a function of distance to market.

This chapter describes the causes for variation in gas quality at different stages from production processes, storage, transportation and handling of LNG. Issues related to the loss of boil-off gas, ageing, stratification and rollover are also examined, in an interchangeability context, showing how receipt of LNG could be an issue without further processing at entry points.

We will also consider the issues of custody transfer and energy accounting between ship and shore storage.

## 4.1 About LNG

- Natural gas condenses into its liquid form at temperatures below -160°C. How is LNG produced, stored, shipped and regasified? This section gives a brief overview of the LNG production and supply processes.

## 4.2 LNG Lifecycle and Weathering

- This covers changes in LNG quality throughout its lifecycle (shipping, transfer and storage) and impacts on interchangeability.

### 4.2.1 What is boil-off gas?

- The more volatile components of LNG boil off first, changing its composition. This section introduces LNG boil-off gas (BOG) and its generation throughout the lifecycle of LNG.

### 4.2.2 How is boil-off gas lost during shipment?

- LNG shipping generates the most BOG. This occurs not only during loading/unloading but also during ship's journey. The causes are broken down and aspects are discussed individually.

### 4.2.3 Ageing in tank

- LNG in a storage tank gets richer as the lighter components "boil-off" and composition may go beyond contractual specifications if left for long. Methods for BOG handling and LNG composition control are important for quality management.

### 4.2.4 Implications of stratification and rollover

- What is LNG stratification and how does it cause LNG rollover? The stratification and rollover phenomena are explained in detail here.

## 4.3 Consistent energy accounting during custody transfer

- This covers the energy measurement and control in LNG trading activities.

### 4.3.1 Custody Transfer

- Custody transfer procedures are in place to ensure precise and consistent calculations for the energy traded despite location and type of contract. The formula used for custody transfer calculation is explained.

### 4.3.2 Custody Transfer Measurement System

- International shipping codes, sophisticated cargo measurement system, calibrated gauges and conditions correction factors are essential for accurate determination of the volume of LNG loaded/unloaded accurately. These are explained here.

## Appendix 4.1: LNG Production, Storage, Shipping and Supply

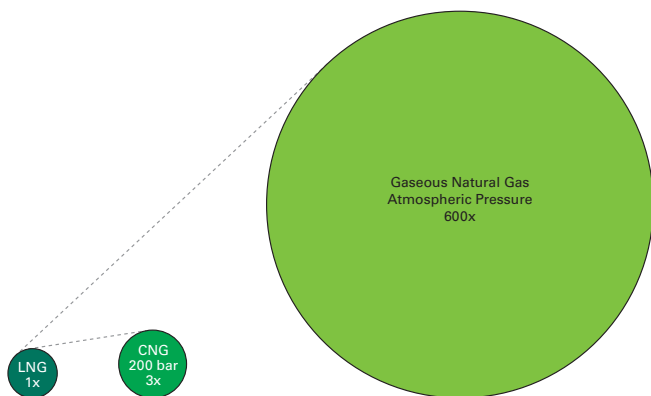
- Natural gas goes through complex impurities removal and liquefaction processes for the production of LNG. The liquefaction processes, LNG containment designs, regasification technologies are described in detail here.

## 4.1 About LNG

**Liquefied natural gas (LNG) forms when natural gas is condensed into its liquid form and stored as a “cryogenic liquid” below its boiling point (-160°C). Liquefying natural gas reduces the volume by about 600 times, making it significantly easier for storage and transportation.**

**LNG is mainly methane (85 - 98% by volume) but the composition of LNG is a function of the composition of the natural gas source and the treatment at the liquefaction facility. Impurities and heavier components are removed prior to the liquefaction process to prevent corrosion and blockages. LNG is shipped in specialised, cryogenic carriers to destinations where it is re-gasified into its gaseous form for various applications.**

Figure 4.1 shows the volumetric representations for LNG, compressed natural gas (CNG) at 200 bar and gaseous natural gas at atmospheric pressure.



**Figure 4.1 – LNG, CNG and Gaseous Natural Gas at Atmospheric Pressure.**

This section is designed to give a brief overview of LNG production and supply. More detailed information is available in Appendix 1.

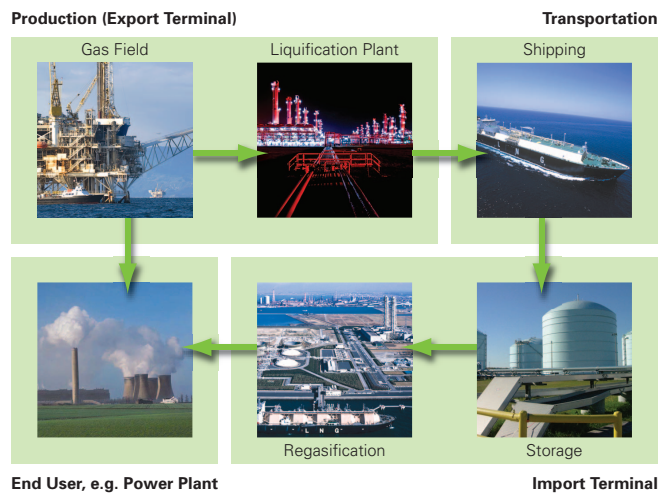
### Why Liquefy Natural Gas?

LNG is typically produced where there are abundant gas resources and limited local market for gas. It provides alternative means of transporting natural gas to markets, as pipeline transportation cannot always be used due to the following constraints:

- Geography. – Tough physical terrain like mountain ranges and deep sea make construction of pipeline challenging. Long distance pipelines can also be costly.
- Politics – International agreements are required across national boundaries and there are associated political risks.
- Economics – A pipeline project requires an appreciable field size and reasonable distance to shore to justify the investment.

Liquefying natural gas makes it feasible to transport natural gas by sea/road tankers and to store it in preparation for its regasification and supply into pipelines. LNG import/export projects are based on three major factors:

- Low gas price at source.
- Transport distances to markets.
- Demand at attractive prices at the destination.



**Figure 4.2 – LNG Chain: Field to Market.**

### LNG Liquefaction Process

The liquefaction process requires stringent purification of the feed gas. Typical processes are shown in Figure 4.3.

#### Offshore Gas Field(s)



#### Liquefaction Plant

##### Natural Gas Treatment

- Condensate (Hydrocarbon liquid, C<sub>2</sub>+) removal
- Acid Gas (Hydrogen sulfide and carbon dioxide) removal
- Dehydration (Water removal)
- Mercury (Hg) removal
- Fractionation
- Inert (Nitrogen) removal

##### Liquefaction

- Liquefied in a cold box -160°C

##### LNG Storage

- In cryogenic tanks

**Figure 4.3 – Natural Gas Pre-treatment at an LNG Liquefaction Plant.**

Besides carbon dioxide (CO<sub>2</sub>), water (H<sub>2</sub>O), hydrogen sulphide (H<sub>2</sub>S), mercury (Hg) and aromatics which need to be removed to ppm (parts per million) level, other components which may also require removal include:

- Nitrogen (N<sub>2</sub>) to < 1%. Nitrogen is more volatile than methane and higher percentages can lead to excessive boil-off gas during storage and shipment.
- Liquefied petroleum gases (LPG, propane/butane). This can be used to control LNG quality – LPG is extracted to produce a leaner LNG. The extracted LPG can also be sold as a chemical feedstock for transportation and heating fuel where there is a local market.

The typical upstream processes to treat the various components to the required specifications are illustrated in Figure 4.4.

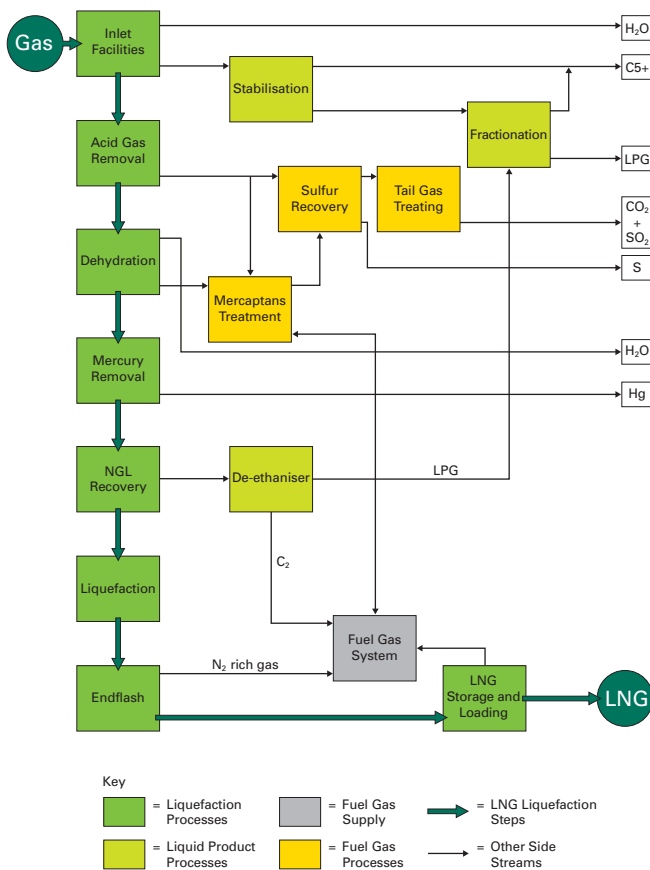


Figure 4.4 – Typical Liquefaction Plant Schematic.

LNG is predominantly methane with small quantities of ethane, propane, butane and nitrogen.



Figure 4.5 – Pre-cooling and Liquefaction Stages.

#### LPG Removal

Most liquefaction plants are fed with gas containing fairly high ethane, propane and butane contents. Nine liquefaction plants worldwide are currently equipped with LPG stripping units: Skikda GL1K, Bontang, Adgas, Arun, Bethioua, NWS, Brega, Bonny Island and Melkoya. This is done for two reasons:

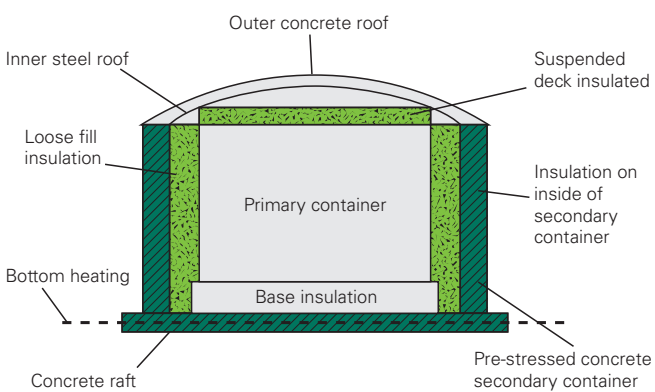
- To produce suitable LNG quality for the markets.
- For value enhancement through LPG sales.

The Skikda plant was the first plant to extract LPG and also to remove ethane which is used as a feedstock in a neighbouring petrochemical plant. Since they were commissioned, the Adgas and NWS plants have been extracting and exporting LPG. At Nigeria's Bonny Island plant LPG recovery and export facilities were added starting with the third train. The Arun and Bontang plants were not designed to export LPG and were modified during debottlenecking operations with facilities for extracting, storing and exporting LPG added.

## How is LNG Stored?

LNG is stored in cryogenic storage tanks at both liquefaction (export) and regasification (import) terminals. A LNG tank typically consists of a nickel alloy inner tank and a reinforced concrete wall outer tank for full containment of LNG in case of spillage.

Besides the safety aspects, LNG tanks are designed to minimise heat ingress into the tanks which will cause a fraction of the LNG to boil (vaporise).



**Figure 4.6** – Cross-section of a Full Containment Storage Tank.

## How is LNG Transported?

LNG is shipped at atmospheric pressure in specialised, dedicated carriers. The cargo is kept cold by insulation and by the effect of a small proportion of the cargo boiling off, typically 0.15% per day. The boil-off gas, or BOG, is used to part meet the fuel requirements of LNG carriers which are predominantly powered by steam turbines, although the industry is moving towards dual fuel diesel propulsion.

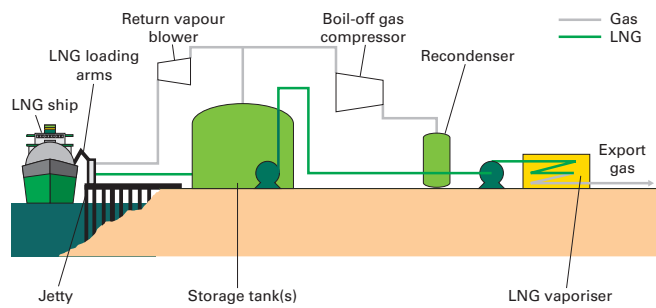
All LNG vessels are double-hulled with the inter-space typically used for ballast. As LNG is very cold, the cargo tanks are separated from the hull structure by thick insulation.

Most LNG carriers have capacities in the range 140,000 - 177,000 m<sup>3</sup>. Smaller capacity vessels (e.g. 75,000 m<sup>3</sup>) are often used to transfer LNG to local markets such as the Mediterranean; and larger vessels (Q-max 216,000 m<sup>3</sup> and Q-max 270,000 m<sup>3</sup>) are becoming more common, having a significant impact on the LNG shipping industry.

## How is LNG Regasified?

At a conventional import terminal:

- LNG is pumped off a moored LNG carrier through LNG unloading arms into pipework to onshore storage tank(s).
- From onshore storage tank(s), LNG is pumped to the recondenser to reabsorb compressed BOG from the storage tank(s) into the bulk LNG.
- The bulk LNG is further pumped to export pressure, then vaporised by exchanging heat from a warmer medium.
- The regasified LNG is exported into pipeline grid in its gaseous form.



**Figure 4.7** – Schematic Representation of a Conventional LNG Import Terminal.

When the ship is unloading LNG, it is usual practice to return cold BOG to the LNG carrier, usually with the aid of a blower, to replace the void space created by pumping LNG off the ship.

There is increasing resistance to the development of onshore LNG regasification terminals due to perceived hazards. The difficulty in obtaining permits for onshore terminals has led to the development of offshore LNG terminals. An offshore LNG regasification terminal is, in simple terms, a facility that has the capability to vaporise LNG and send out high pressure natural gas to shore.

The composition of LNG changes throughout its lifecycle due to preferential evaporation of components during shipping, transfer and storage. Operational problems such as stratification (explained later) and rollover are results of mixing LNG of different compositions.

### 4.2.1 What is boil-off gas?

Just like any liquid, LNG vaporises at temperature above its boiling point (-160°C) and generates boil-off gas (BOG) which is predominantly nitrogen and methane. Ship loading/unloading processes generate the largest amount of BOG, about 8-10 times that generated in a base load operation supplying a constant load of gas to the natural gas grid over a period of time. BOG can be either combusted as fuel or compressed for resale or re-liquefied.

LNG is a liquid below its boiling point. Thus any heat ingress into LNG will cause a fraction of it to boil (vaporise). Changing the pressure of the LNG, including changes in ambient pressure, will also cause vaporisation. The gas that is produced is frequently called boil-off gas (BOG). There are two main sources of boil-off gas:

- That which occurs during ship loading and unloading.
- That generated during base load operations when a steady flow of natural gas is being supplied to the grid over a period of time.

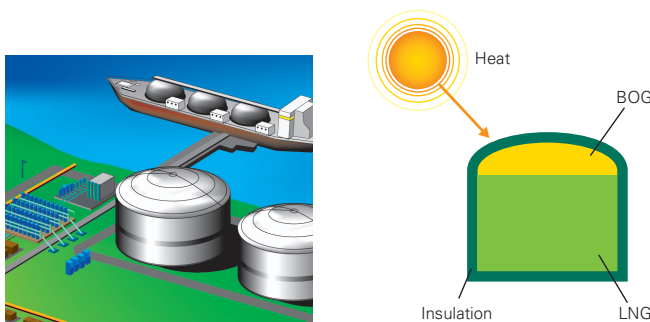


Figure 4.8 – Generation of LNG Boil-off Gas.

Table 4.1 – Comparisons between BOG Produced from Base Load Operations and Ship Loading/Unloading.

	BOG produced from	
	Ship Loading and Unloading	Base Load Operations
Description	<ul style="list-style-type: none"> <li>• BOG produced during ship loading and unloading is typically 8 - 10 times that of base load BOG, mainly due to vapour return (displacement) from ship or onshore tanks.</li> </ul>	<ul style="list-style-type: none"> <li>• Occurs due to heat ingress into storage tanks and pipes etc.</li> <li>• Typically 0.05% of the site tank storage capacity per day and 0.15% of a ship's tank capacity per day.</li> </ul>
Characteristics	<ul style="list-style-type: none"> <li>• High flowrate.</li> <li>• Short duration (typically 12 hours every 3 - 5 days).</li> <li>• Flowrate determined by pressure/ temperature disparities between ship and tanks.</li> </ul>	<ul style="list-style-type: none"> <li>• Predominately nitrogen and methane.</li> <li>• A small but continuous flow.</li> <li>• Flowrate depends on atmospheric temperature and pressure.</li> </ul>
Applications	<ul style="list-style-type: none"> <li>• Some BOG needs to be returned to the ship to replace the LNG removed. The rest can either be:                             <ul style="list-style-type: none"> <li>– (Compressed and) combusted</li> <li>– Compressed and exported as gas</li> <li>– Compressed and liquefied</li> </ul> </li> </ul>	<ul style="list-style-type: none"> <li>• It can either be:                             <ul style="list-style-type: none"> <li>– (Compressed and) combusted (for heating, power generation or flare).</li> <li>– Compressed and exported as gas.</li> <li>– Compressed and liquefied and exported as gas.</li> </ul> </li> <li>• BOG produced during ship transit is generally used in the ship's engines although some modern ships have BOG re-liquefaction facilities.</li> </ul>

Most BOG in the LNG chain is generated by the LNG ships. Heat ingress to storage tanks, both onshore and at sea is the prime cause of BOG.

LNG has no set composition so the LNG industry provides reference BOG gas rates based on pure methane. The latent heat (amount of heat required to vaporise a unit weight of the liquid) of methane is lower than for a LNG mixture therefore, BOG rates for LNG will be lower than those quoted for pure methane. All guarantees are against pure methane and are therefore more stringent than would be experienced in practice.

## 4.2.2 How is boil-off gas lost during shipment?

Most BOG arising in the LNG chain is generated by the LNG ships themselves. BOG is produced during the journey and also whilst loading and unloading, for the following main reasons:

- Heat ingress into the tanks and pipelines
- Cooling down of tanks, ship's manifolds, loading/unloading arms and pipelines.
- Movement of LNG – Sloshing caused by wave action during shipping and mixing of LNG with existing stocks in tanks onboard or onshore.

In addition to these, a relatively large amount of BOG is generated during the loading/unloading process.

### BOG released during ship's journey

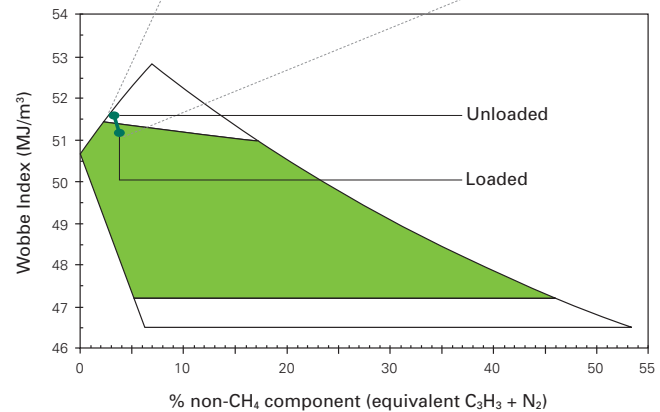
When LNG is shipped by tanker, the composition of the gas changes during the ship's journey (see Figure 4.9). This is called ageing or weathering and occurs because of evaporation due to the following actions:

- Heat ingress via the tank insulation.
- Wave action (sloshing).
- Tank cooling/spraying during ballast voyages (the return voyage when 98.5 - 99.0% of the LNG is offloaded).
- Forced evaporation by heating for gas fired propulsion needs.

Details of these are illustrated in Figure 4.10.

The rate of evaporation of the more volatile components, nitrogen and methane, is higher than that of the heavier components. Thus evaporation leads to an increase in the Gross Calorific Value (GCV) of the stored LNG. With LNG that is rich in heavy components with low nitrogen content, the Gross Calorific Value will increase even more. This ageing process must be taken into account when determining whether the LNG is likely to meet terminal specifications, especially if a long shipping journey is involved. During transport between the Middle East and the USA, for example, the Gross Calorific Value of the gas can increase by about 0.2 - 0.3 MJ/m<sup>3</sup>(n) or 5 - 8 Btu/scf.

Composition		Loaded	Unloaded
Day		0	21
Temperature	°C	-163.8	-161.0
Pressure	bara	1.143	1.143
N <sub>2</sub>	mol%	0.963	0.367
CH <sub>4</sub>	mol%	92.667	93.080
C <sub>2</sub> H <sub>6</sub>	mol%	5.981	6.157
C <sub>3</sub> H <sub>8</sub>	mol%	0.372	0.383
nC <sub>4</sub>	mol%	0.006	0.006
nC <sub>5</sub>	mol%	0.000	0.000
CO <sub>2</sub>	mol%	0.006	0.006
density	kg/m <sup>3</sup>	447.3	432.8
Gross CV	MJ/m <sup>3</sup> 15/15	39.4	39.6
Wobbe	MJ/m <sup>3</sup> 15/15	51.2	51.6



**Figure 4.9** – Example of Wobbe Index Change over a 21-day Journey.





**(a) Heat Ingress into the LNG Tank**

- Main cause for BOG generation on ship.
- Typical heat ingress rates are currently 0.15%/day, but older ships often designed with values up to 0.25%/day.
- Smaller ships tend to have larger BOG rates, typically 0.3%/day.

**(b) Wave Action**

- The issue is poorly understood but many authors agree that wave action, particularly in heavy seas, causes sloshing of LNG and produces BOG.

**(c) Tank Cooling/spraying during Ballast Voyages**

- Tanks need to be cooled down to at least -80°C after dry-docking or first commissioning.
- Sporadic spraying of LNG into the top of the tank by pumping LNG from the bottom of the tank is used to reduce the increasing temperatures at the top of the tank during empty return (ballast) voyages.
- Overall, BOG generation during ballast voyages is lower than when laden. Typically the laden voyage accounts for 55% of the BOG and the ballast voyage 45%.

**(d) Forced Evaporation by Heating for Gas Fired Propulsion Needs**

- On a laden voyage the BOG system might operate at tank pressures between 50 - 90 mbarg with the BOG flow set to allow generation of 50 - 60% of engine energy requirements. The remaining fuel is supplied by diesel or heavy fuel oil.
- Most modern carriers include forcing vaporisers which vaporise additional BOG to allow the ship to operate on BOG alone. The use of forcing vaporisers depends on relative fuel economics (gas compared to heavy fuel oil) and charterer preference.

LNG carriers with a typical capacity of, say, 153,000 m<sup>3</sup> are loaded at about 12,000 m<sup>3</sup>/h. The volume of liquid LNG loaded displaces an equivalent quantity of vapour in the ship's empty cargo tanks which is returned to the LNG storage tanks for processing in the site's fuel gas system. This BOG will be available for typically 12 hours in each loading cycle. If the ship's tanks are warm, loading takes a longer period of time as initially volumes of LNG are vaporised when they contact the warm sides of the LNG tanks, thereby cooling them.

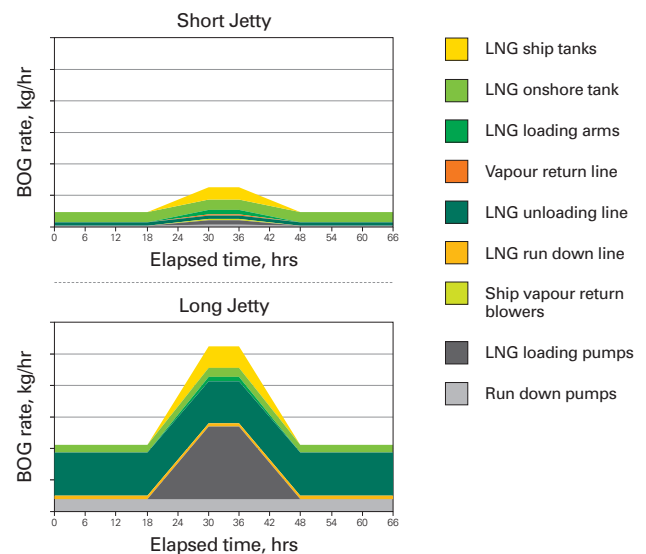
During loading, more than one LNG storage tank can be used simultaneously to load the carriers. Where jetty lines are long, the loading line generates significantly more BOG due to heat ingress from the pumps as a result of the larger duty. With relatively short jetty/transfer lines < 1 km, the heat component from LNG pumping is relatively small (typically around 5% of total BOG). However, for example where the LNG must move in excess of 7 km the pumping component becomes significantly larger at an estimated 45% of total BOG.

**Figure 4.10** – Causes of BOG Release during Ship Journey.

**Boil-off gas released during the ship loading process**

BOG released during ship loading arises from a number of sources:

- Vapour return (displacement) from ship's tanks.
- Heat input from inefficiencies in loading pumps.
- Cooling down of the ship's manifold and loading arms.
- Mixing of loaded LNG with the initial amount of LNG (known as "heel"; is there to keep the tank at a suitably low temperature) in ship.
- Cool down of jetty lines (if not continuously cooled).
- Cooling down ship's tanks:
  - Prior to loading if returned with insufficient heel.
  - After dry-docking, off-hire or during initial commissioning.



**Figure 4.11** – BOG Loss Comparison for Short and Long Jetties.

**Boil-off gas released during the ship unloading process**

BOG associated with ship unloading arises from:

- Vapour return (displacement) from storage tanks.
- Heat input from inefficiencies in the ship's unloading pumps.
- Cooling down ship's manifold and unloading arms prior to discharge.
- Mixing of unloaded LNG with existing stock of different quality.
- Cooldown of jetty lines (if not continuously cooled).
- Flashing into storage tanks due to a mismatch of pressure between the ship's storage tanks and the terminal storage tanks.

### 4.2.3 Ageing in tank

**Ageing or weathering of LNG in a storage tank results in changes in LNG composition over time, caused by heat ingress and preferential loss of volatile components. This is a slow but continuous process. The BOG could either be compressed and exported directly to the transmission pipeline, or re-condensed back into the LNG tank to maintain the LNG quality. If the LNG quality changes significantly so that it cannot be exported at contractual rates, a "less-profitable" cargo may be used for mixing and to restore the desired quality.**

LNG is stored within highly insulated tanks at 50 - 200 mbarg pressure. Typical tank volumes are from 80,000 - 200,000 m<sup>3</sup>. Heat input from the surroundings means that BOG is generated continuously within the tanks. LNG storage tanks are typically designed to reduce heat ingress from the ambient environment and due to solar heating so that vaporisation is less than 0.05 wt% of the total tank contents per day although this can vary between 0.02 - 0.1 wt%.

LNG is a mixture of components and the more volatile components (methane and nitrogen) are lost preferentially, so that the temperature of the stored LNG will increase with time. This process is called ageing or weathering and is normally a fairly slow process. For nitrogen-free LNG, the density also increases steadily with time. Weathering is particularly important if:

- The heat leakage from the walls of the tank is relatively high as in the case of some in-ground tanks.
- The storage period is long as in the case of peak shaving installations.

#### Boiling or Evaporation?

Under normal storage conditions the liquid does not boil: rather the heat input to the liquid from the floor and walls of the tank is absorbed and transferred by convection to the liquid surface where evaporation takes place. A convective circulation is set up of slightly warm less dense liquid moving upwards close to the tank walls. Warmed liquid reaching the surface cools by evaporation, becomes more dense than the liquid surrounding it, and returns to the tank bottom.

### BOG Re-condensation

Boil-off gas (BOG) is an issue in every LNG terminal. The use of recondensers to convert BOG back into LNG during gas send out periods is now normal practice.

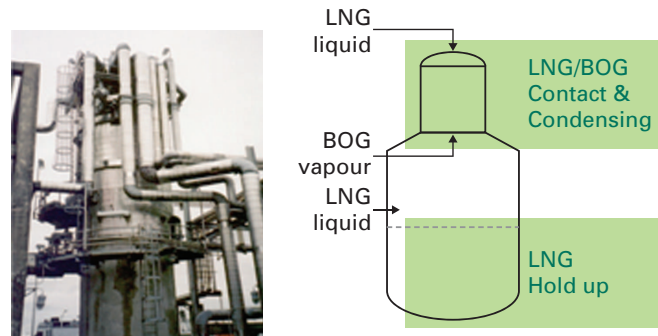


Figure 4.12 – LNG Recondenser.

However, for a recondenser to work there needs to be a minimum gas send-out. If a terminal has a reduced or even zero send-out because expected cargoes are being diverted to other destinations or demand is seasonal, an alternative approach needs to be considered.



### “Pipeline” BOG Compression



**Figure 4.13** – “Pipeline” BOG Compressor.

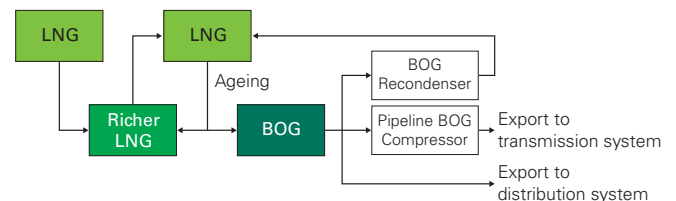
Historically, a high pressure “pipeline” BOG compressor is included, particularly in US terminals, to allow the BOG to be exported directly to the transmission system. The utilisation of these machines has been very low and the economics therefore difficult to justify. This solves the immediate problem of disposing of BOG but does not solve the issue of LNG loss (as BOG).

### Mixing with ‘Fresh’ LNG

If the LNG in a tank is not used for some time, LNG stock levels will reduce as BOG is disposed of (for example, into the local medium pressure gas distribution system) and secondly the quality of the LNG will change. BOG consists of the lightest components of the LNG and is therefore predominantly nitrogen and methane. With these components preferentially boiling off, the composition of the LNG in storage can change to such an extent that

supply/export is constrained (e.g. the gas no longer meets pipeline specification). A “less profitable” cargo, in gas trading terms, may then need to be delivered to restore the contractual viability of the terminal. The options for LNG BOG handling are illustrated in Figure 4.14.

“Less profitable cargo”



**Figure 4.14** – Option for LNG BOG Handling.

### Re-liquefaction of BOG

Some terminals are now considering the inclusion of re-liquefaction facilities for the BOG to ensure that BOG is not lost from the system and that the stock remains in prime condition and can be regasified at the optimum market price. These liquefaction plants are similar to those being employed on the new Q-flex and Q-max ships and generally use of a nitrogen based refrigeration cycle which has a low capital investment requirement but relatively high operating cost.



#### 4.2.4 Implications of stratification and rollover

LNG rollover is a phenomenon caused by rapid mixing of LNG layers of different densities (stratification). It can result in large amount of BOG generation and elevated tank pressure within short periods.

However, if controlled carefully to avoid the rollover effect, stratification may be encouraged (or created) in onshore storage tanks as evidence shows that BOG rates can be reduced if layers are formed.

**Stratification** refers to the formation of LNG layers of different densities within LNG storage tanks.

LNG stocks of different densities can form stable stratifications in LNG tanks, usually as a result of inadequate mixing of fresh LNG with existing LNG of different density in the tank. Once a stable stratification has been formed, heat and mass transfer across the interface is relatively small. The two layers behave as separate regions, each with its own density and temperature but the bottom layer is composed of liquid that is more dense than the top layer.

##### Stratification

For stratification to occur the kinetic energy of the incoming fluid must be smaller than the buoyancy forces acting on the entrained liquid. For stratification therefore:

$$g\Delta\rho l \gg \rho u^2$$

where:  $g$  = gravitational constant  
 $\rho\Delta$  = density difference  
 $\rho$  = density  
 $l$  = layer size  
 $u$  = velocity

This means that the velocity must be lower than 0.1m/s for a 1m layer and that lighter LNG is being top filled or heavier LNG is bottom filled.

Usually the temperature of the lower layer increases more rapidly than that of the upper layer as much of the heat ingress to the storage tanks occurs at or near the base of the tank.

Subsequently, due to heat leakage into the tank, heat and mass transfer between the layers and evaporation at the liquid surface, the layers equilibrate in density and eventually mix. The spontaneous mixing of layers is called **rollover**. This phenomenon is shown in Figure 4.15.

If, as is often the case, the liquid in the bottom layer has become superheated with respect to the pressure in the tank vapour space, the rollover can be accompanied by an increase in vapour release. Sometimes the increase is rapid and large: in a few instances the pressure rise in the tank has been sufficient to cause pressure relief valves to lift. The rollover phenomenon requires a significant time period to develop to levels of concern.

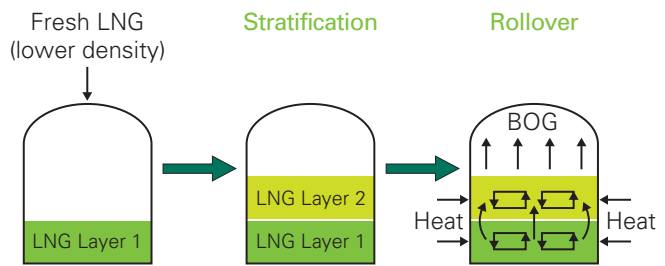


Figure 4.15: Stratification and Rollover in a LNG Tank

##### Nitrogen Increases the Chance of a Rollover

Nitrogen in LNG is both dense and volatile. If it is present in percentage proportions, its preferential loss causes a decrease in density of the remaining LNG. Large volumes of nitrogen might be expected to influence LNG fluid behaviour and potentially increase the chance of a rollover. The nitrogen content of LNG for transportation is usually limited to 1%.

##### Stratification reduces BOG production?

There is considerable evidence that BOG rates are reduced if layers are formed and remain separated. BOG will therefore remain in the liquid LNG until mixing breaks the stratification.

- Warm, poorly mixed LNG in storage will boil off rapidly if it becomes well mixed.
- Partial mixing will occur during the ship loading process.
- Full mixing is probably only achieved when the vessel is underway and ocean conditions cause movement and mixing within the cargo.

In this way, deficiencies within the liquefaction plant would only manifest themselves during ship loading with increased BOG (potentially leading to flaring), or on the LNG carrier whilst in transit.

Therefore, stratification may be specifically encouraged in a storage tank at an import terminal to reduce BOG losses. The interfaces between the deliberately created layers are then carefully monitored using a densitometer to track the approach of rollover. The tank contents are then pumped out before the risk of rollover becomes significant.

**LNG is sold in terms of its energy content. Custody transfer involves activities and measurements taken both on the ship and at the terminal.**

Custody transfer procedures are contractually agreed between the LNG buyer and shipper/seller for the determination and calculation of the energy transferred from buyer to seller. The formula for calculating the LNG transferred depends on the agreed contractual sales conditions. LNG sales can be:

- FOB (Free on board);
- CIF (Cost insurance freight), or
- DES (Delivery ex ship).

In the case of a FOB sale, the determination of the energy transferred and invoiced for will be made in the loading port. In the case of a CIF or a DES sale, the energy transferred and billed will be determined in the unloading port.

The energy content of unloaded LNG is determined from the:

- Volume of LNG transferred.
- Density of the LNG.
- Gross calorific value of the LNG.
- BOG returned from the Terminal to the Ship during unloading (to replace the volume vacated in the tanks by unloading LNG).
- BOG sent back onshore by the LNG carrier when loading. In most cases, this energy is returned free of charge to the loading facilities.

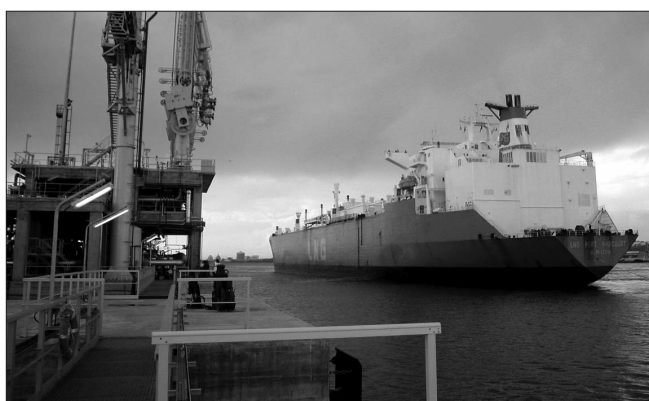
### 4.3.1 Custody Transfer

**There are four parameters that are used to calculate and determine the net quantity of energy transferred from LNG shipper/seller to LNG buyer – (i) LNG volume unloaded; (ii) LNG density; (iii) LNG gross calorific value; and (iv) energy of gas from terminal to ship during unloading, or sent ashore during ship loading.**

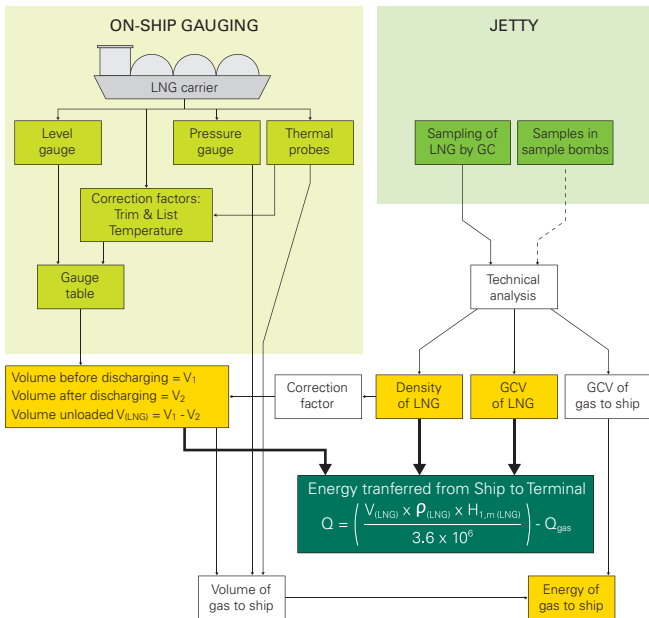
LNG is sold in terms of its energy content which is typically measured in GWh, BTU or Therms. Custody transfer is the expression used to describe the determination and calculation of the net quantity of energy (Q) transferred from the LNG shipper/seller to the LNG buyer. Table 4.2 shows the four elements that must be determined to be able to calculate the net energy transferred to the terminal. Also shown in the table are the measurable parameters used to determine the four elements of Q, and the formula for calculating the quantity of energy transferred (Note that for this case the denominator 3.6 x 10<sup>6</sup> is required to convert Q from units of MJ into units of GWh).

**Table 4.2 – Elements and Measurable Parameter for Custody Transfer.**

Elements of Q	Measurable Parameters
LNG volume unloaded, $V_{(LNG)}$	– Level
LNG density, $\rho_{(LNG)}$	– Pressure
LNG gross calorific value, $H_{i,m(LNG)}$	– Temperature
Energy of gas from terminal to ship during unloading or sent ashore during ship loading, $Q_{gas}$	– Condition of ship (e.g. trim/list)
Formula for Q (units: GWh)	– Volume calibration
$Q = (V_{(LNG)} \times \rho_{(LNG)} \times H_{i,m(LNG)} / 3.6 \times 10^6) - Q_{gas}$	– Sampling
	– Gas testing
	– Cargo (vapour/liquid) remainders
	– Vapours displaced/boil-off



The derivation of the four elements of Q is shown schematically in Figure 4.16 for an import terminal.



**Figure 4.16** – Schematic of the Custody Transfer Process.

The four elements are calculated as follows:

**(a) Volume of LNG unloaded**

The method used for measuring the volume, V(LNG) (units: m<sup>3</sup>), is based on the LNG carrier's instruments. It involves the use of level gauges and calibration tables and is called gauging. Usually a quantity of LNG, called 'heel', remains on board after unloading to keep the tanks cold. Determination of the volume transferred requires two measurements, one before and one after loading or unloading; so the result will be two LNG volumes. The difference between the larger volume and the smaller volume will represent the volume of liquid transferred. The procedure recommended in the GIIGNL (LNG importers association) Custody Transfer Handbook is most commonly used.

For the procedure described above, it is necessary to ensure that there is no on-ship use of LNG/BOG during loading/unloading.

**(b) Density of LNG**

The density of LNG, ρ(LNG) (units: kg/m<sup>3</sup>), is derived from the composition of the LNG transferred and the temperature of the LNG from measurements in the LNG carrier's tanks. The LNG composition is typically sampled continuously by a terminal gas chromatograph (GC). The GC can automatically calculate density from compositional data according to a method agreed by the shipper/seller and terminal/buyer. Typical standards which are used are ISO6578 and NBS1030 (National Bureau of Standards). The universally accepted

method for the calculation of LNG liquid density is the revised Klosek-McKinley equation.

As a backup, in the event of failure or malfunction of the GC, or in case any party disputes the results of the GC, samples of unloaded LNG can be collected and stored in containers (or 'sample bombs').

**(c) Gross Calorific Value of LNG**

The Gross Calorific Value (GCV) of LNG (units: MJ/kg), is derived from the composition of the LNG transferred, in accordance with the method agreed by the shipper/seller and buyer/terminal and can be automatically computed by a GC. This is the energy of combustion of gas (vaporised LNG) and not liquid LNG. In the event of failure or dispute with GC, an alternative method of calculation, as agreed between the shipper and buyer/terminal can be employed.

Typical standards used are ISO6976, GPA2145 and GPA2172. Contracts should state the reference conditions to be used, the key conditions being the combustion temperature and the metering temperature. If these are not stated this could lead to errors in the custody transfer calculation. The difference in Gross Calorific Value calculated at the reference conditions typically used in different world jurisdictions are indicated in Table 4.3 below for the gas composition provided.

**Table 4.3** – Effect of Reference Conditions on Gross Calorific Value.

Temperature	°C	-161
Pressure	bara	1.143
Nitrogen, N <sub>2</sub>	mol%	0.367
Methane CH <sub>4</sub>	mol%	93.080
Ethane, C <sub>2</sub> H <sub>6</sub>	mol%	6.157
Propane, C <sub>3</sub> H <sub>8</sub>	mol%	0.383
nC <sub>4</sub>	mol%	0.006
nC <sub>5</sub>	mol%	0.000
Density	kg/m <sup>3</sup>	442.9
Volume factor	kg/m <sup>3</sup>	620.5

Jurisdiction	Combustion	Metering	GCV MJ/kg	± to average
Japan	0	0	54.880	0.15%
	15	0	54.794	-0.01%
UK, Italy	15	15	54.794	-0.01%
France, Spain	25	0	54.738	-0.11%
USA	60°F	60°F	54.791	-0.02%
Average			54.799	

#### (d) Energy of gas displaced

The volume vacated in a ship's tanks by pumping out LNG is replaced by natural gas from the terminal through the vapour return arm. The energy content of this gas,  $Q_{\text{gas}}$  (units: GWh), is subtracted from the total energy of the LNG delivered to the terminal to give the net energy. The natural gas returned to the ship represents a proportion of that gas which boils off, due to heat ingress, during the unloading operations and vapour displaced from the storage tanks during fill (the remainder of the boil off gas being processed by the terminal). Returned natural gas vapour may be mixed with LNG in a jetty "de-superheater," to cool down the natural gas vapour, before entering the ship's tanks.

Energy content,  $Q_{\text{gas}}$  is determined knowing the total volume of LNG displaced, the average temperature  $T$  (°C) of gas in the ship's tanks after completion of unloading, the absolute pressure  $P$  (kPa) in the tanks and the Gross Calorific Value of the gas  $H_{v,m(\text{LNG})}$  (MJ/sm<sup>3</sup>). Since the Gross Calorific Value is calculated on a volume basis the reference conditions for both the combustion and metering temperatures and pressures should be stated.

The conversion of the volume to reference conditions is performed using temperature and pressure ratios which assume an ideal gas. The formula commonly used to calculate  $Q_{\text{gas}}$  for a reference condition of 15°C and 101.325 kPa is:

$$Q_{\text{gas}} = V_{\text{LNG}} \times \frac{288.15}{(273.15 + T)} \times \frac{P}{101.325} \times \frac{H_{v,m(\text{LNG})}}{3.6 \times 10^6}$$

Note that the return gas to the ship may not be separately sampled. The composition of the vapour return to the ship is not the same as the LNG delivered, though it can be assumed to have either, (i) the same calorific value (n.b. expressed in volumetric, rather than mass, terms) as the LNG delivered, or (ii) be 100% methane.

The same formula would be used to calculate the gas sent back from the ship during the loading operations although this is not always included in the custody transfer calculation.

#### 4.3.2 Custody Transfer Measurement System

**The custody transfer measurement system fitted on LNG carriers must comply with the international LNG shipping codes, compatible with the terminal and calibrated regularly.**

**Gauging allows calculation of LNG volume in ship's storage tanks using numerical tables relating to its height and applying condition-based correction factors. The total amount of LNG loaded/unloaded is determined by the level differential measured during initial and final gauging.**

LNG carriers are fitted with sophisticated means of cargo measurement, the equipment of which is usually called the 'Custody Transfer Measurement System' (CTMS). An independent surveyor usually produces the gauge tables during the building of the LNG carrier. The ship CTMS is used in preference to terminal tank measurements because the elements of it are specially calibrated by a classification society, to a high degree of accuracy, and periodically recalibrated.

Each LNG carrier destined to visit a terminal needs to be approved in advance to make sure that it will be compatible with the jetty and the terminal. The vessel needs to confirm that it complies with prevailing standards of the LNG shipping industry, including the "International Ship and Port Security Code"; and, more specifically, the standards set by the Society of International Gas Tanker & Terminal Operators Ltd (SIGTTO). Furthermore, the ship is required to provide details of its CTMS system specifications and methods.

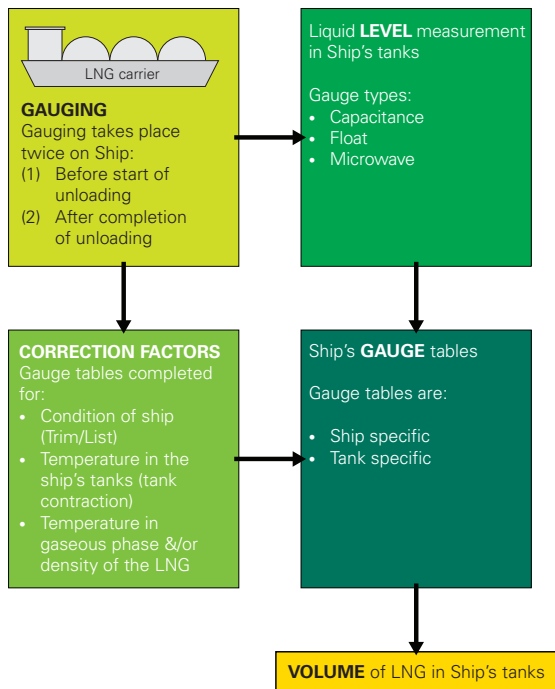
Gauging is the term given to measuring the level of LNG in ship storage tanks and using numerical (or gauge or 'sounding') tables which relate height of liquid in the tanks to the volume contained in the tanks under certain 'ideal' conditions. As gauging does not take place under 'ideal' conditions, the operation also includes the measurement of certain other parameters for completing the gauge tables with correction factors to reflect actual (non-'ideal') conditions. The correction factors are automatically calculated using the computer system on the ship, and are included on various ship certificates for custody transfer. The reference temperature of gauge tables is usually -160°C.

To determine the volume of LNG unloaded/loaded from/into the ship's tanks to/from the terminal, gauging takes place on board the ship twice:

- **Initial Gauging** – After connection of the terminal unloading/loading arms, but prior to the start of the unloading/loading operations from/to the ship to/from the terminal. Initial gauging is required to determine the starting volume of LNG in the ship's tanks.
- **Final Gauging** – After cessation of the unloading/loading operations, and disconnection of the liquid unloading/loading arms, to determine the final volume of LNG remaining in the ship's tanks.

Figure 4.17 shows a schematic overview of gauging.

## Appendix 4.1 LNG Production, Storage, Shipping and Supply



**Figure 4.17** – Gauging Process.

LNG is a colourless, odourless clear fluid and is about half the density of water. Typical properties of LNG are:

**Table 4.4** – Typical Properties of LNG.

Parameter	Value
Boiling point	-160 to -162°C
Molecular weight	16 – 19
Odour	None
Colour	None
Density	425 - 485 kg/m <sup>3</sup>
Calorific value	38 - 44 MJ/Nm <sup>3</sup>
Specific heat capacity	2.2 - 3.7 kJ/kg/°C
Viscosity	0.11 - 0.18 cP
Thermal conductivity	0.19 - 0.22 W/m°C

### (a) Why Liquefy Natural Gas?

The gas may be the result of natural gas produced in conjunction with oil production (“associated gas”) or large “dry gas” discoveries (“unassociated gas”). In either case, the local market may be too small to consume the complete production and pipelines may be uneconomical for delivering the gas to consuming markets.

Technology for bulk shipment of natural gas in compressed form (i.e. CNG at 200 bar pressure or more), which is an alternative means of gas transport, is close to being commercialised. CNG gives a storage density of around 200 to 1, so is still only about a third as dense in energy terms as LNG.

**Table 4.5** – Brief Comparisons between Natural Gas, CNG and LNG Technologies.

	NG	CNG	LNG
Description	1 bar 5 to 15°C Energy density = 1 v/v	200 - 250 bar -30 to 50°C Energy density = 200 - 250 v/v	1 bar -160°C Energy density = 600 v/v
Advantage	Minimum treatment and compression required.	Higher energy density than NG. Cheaper ships than LNG. No need for cryogenic liquefaction plant.	Highest energy density. Mobile transportation, independent of pipeline infrastructure.
Disadvantages	Low energy density. Expensive for large volume or long distance transportation.	Technology is not commercialised. High upstream compression cost.	High liquefaction and re-gasification costs. BOG losses over time.

v/v = volume of gas stored per volume of storage capacity.

### (b) LNG Liquefaction Process

Growing demand for LNG is leading to increased production from more difficult gas reservoirs which may contain higher levels of acid components (sulphur compounds and carbon dioxide) and may be located in more inhospitable environments where more production is by full well stream transfer. The consequences are that LNG facilities will increasingly need to be designed for higher levels of acid components and various inhibitors.

The levels to which the trace components generally need to be removed as part of the liquification process are summarised in Figure 4.6.

**Table 4.6** – Required Component Specifications Prior to Liquefaction.

Component	Specification	Unit Operation
Water (H <sub>2</sub> O)	< 1 ppmv	Dehydration
Carbon dioxide (CO <sub>2</sub> )	< 50 ppmv	Acid Gas Removal
Hydrogen sulphide (H <sub>2</sub> S)	< 3.3 ppmv	Acid Gas Removal
Organic S (RSH, COS, CS <sub>2</sub> )	< 50 ppmv	Acid Gas Removal
Mercury (Hg)	< 10 ng/Nm <sup>3</sup>	Mercury Removal
C <sub>5</sub> + Hydrocarbons	< 1,000 ppmv	Front End of Liquefaction
Aromatics (BTX)	< 10 ppmv	Front End of Liquefaction
Nitrogen (N <sub>2</sub> )	< 1%	End flash

The choice of liquefaction process does not influence the quality of LNG. This can be varied for each process and depends on the degree of refrigeration used and the gas processing carried out.

The typical processes to treat the various components to the required specifications are described in detail in Table 4.7.



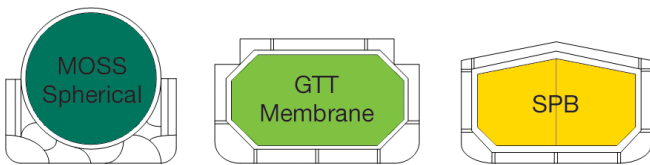
**Table 4.7** – Impurities Removal for Liquefaction Process.

Unit Operation	Description	Component(s) removed	Specification
<b>Acid Gas Removal</b>	<ul style="list-style-type: none"> <li>• Amine-based process such as MDEA.</li> <li>• To reduce corrosion problems.</li> <li>• A sulphur recovery unit, normally a Claus type process, will often be required to convert the recovered hydrogen sulphide from the acid gas unit to sulphur.</li> </ul>	<ul style="list-style-type: none"> <li>• Hydrogen sulphide (H<sub>2</sub>S)</li> <li>• Carbon dioxide (CO<sub>2</sub>)</li> </ul>	<ul style="list-style-type: none"> <li>• 3.3 ppmv</li> <li>• 50 ppmv</li> </ul>
<b>Dehydration Plant</b>	<ul style="list-style-type: none"> <li>• To prevent water solidification in the liquefaction process and to reduce corrosion.</li> <li>• A molecular sieve type of process is typically used.</li> </ul>	<ul style="list-style-type: none"> <li>• Water (H<sub>2</sub>O)</li> </ul>	<ul style="list-style-type: none"> <li>• 1 ppmv</li> </ul>
<b>Mercury Removal</b>	<ul style="list-style-type: none"> <li>• Mercury will cause damage to cryogenic aluminium equipment.</li> </ul>	<ul style="list-style-type: none"> <li>• Mercury (Hg)</li> </ul>	<ul style="list-style-type: none"> <li>• 10 ng/m<sup>3</sup></li> </ul>
<b>Heavy Hydrocarbon Removal</b>	<ul style="list-style-type: none"> <li>• Typically a scrub column is used prior to liquefaction to remove heavy hydrocarbons and aromatics which could freeze out in the main cryogenic exchangers.</li> </ul>	<ul style="list-style-type: none"> <li>• C<sub>5</sub>+ hydrocarbons</li> <li>• Aromatics</li> </ul>	<ul style="list-style-type: none"> <li>• 1000 ppmv</li> <li>• 10 ppmv</li> </ul>
<b>Mercaptan Removal</b>	<ul style="list-style-type: none"> <li>• Mercaptans are corrosive and toxic.</li> <li>• Mercaptans are partly removed in the acid gas unit. They need to be separated from the hydrogen sulphide as they can cause problems in the Claus process.</li> <li>• Also partly removed in the regeneration gas from the molecular sieves. They need to be separated from the molecular sieve regeneration gas.</li> </ul>	<ul style="list-style-type: none"> <li>• Mercaptans</li> </ul>	0
<b>Nitrogen Removal</b>	<ul style="list-style-type: none"> <li>• If present in quantity, it is removed in the last stage of liquefaction, known as the end flash to avoid the risk of a roll-over.</li> <li>• The end flash is also useful in reducing LNG temperatures and pressures without using energy and capital intensive refrigeration. As the boiling points of the nitrogen and methane are similar, multiple pressure levels, distillation columns, etc are used to minimise end flash methane losses.</li> </ul>	<ul style="list-style-type: none"> <li>• Nitrogen (N<sub>2</sub>)</li> </ul>	1%
<b>LPG Removal</b>	<ul style="list-style-type: none"> <li>• LPG is generally removed in a single distillation/scrub column which gives moderate to high extraction. A turbo-expander based process would give higher levels of extraction.</li> <li>• Several processing options exist for LPG removal. The best process for a given application depends on factors such as the feedstock composition, the degree of extraction required and the capacity.</li> </ul>	<ul style="list-style-type: none"> <li>• Liquefied petroleum gas (LPG)</li> </ul>	

### (c) How is LNG Transported by Sea?

LNG is shipped at atmospheric pressure in specialised, dedicated carriers.

LNG carriers have evolved into, effectively, three highly specialised designs known as 'Moss' type, 'Membrane' type and SPB (Self-supporting Prismatic shape IMO Type-B cargo containment system) type carriers.



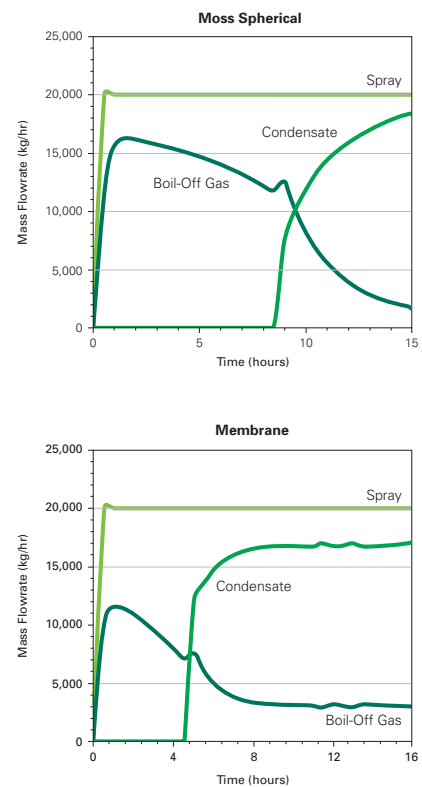
**Figure 4.18:** LNG Containment Designs

'Moss' type containment is installed on more than 70 LNG vessels. This design shows good resistance against LNG sloshing caused by wave action, thereby reducing BOG generation due to sloshing effect. The upper half of each sphere protrudes above deck and is painted in a light colour to help to reduce boil off due to solar radiation.



### Cooldown Rates for LNG Carriers

Hyundai Heavy Industries has provided a comparison of cooldown rates for Moss and membrane type ships. Cool down times are identical at 16 hours from ambient, but the Moss ships require significantly larger volumes of LNG and therefore create more BOG than membrane ships. From Mitsubishi's figures the Moss ship requires about 50% more LNG to cool down and generates about 45% more BOG.



**Figure 4.19 –** Cooldown Rate for Moss and Membrane Carriers.

Gas Transport & Technigaz (GTT), who owns the two patents for the membrane-type containment system, requires a maximum tank temperature of  $-80^{\circ}\text{C}$  before loading can commence but strongly recommend not starting the fill process if temperatures are above  $-130^{\circ}\text{C}$ . Cool down rates are given as  $20^{\circ}\text{C}/\text{hour}$  for the first five hours (from ambient) and then  $10 - 15^{\circ}\text{C}/\text{hour}$ .

## The Development of LNG Vessels

### 1975

- Until 1975, there was no universally accepted ship design and a variety of vessels traded, with the largest LNG carrier capacity at the time being ~90,000 m<sup>3</sup>.
- From 1975, a 'standard' worldscale LNG carrier design emerged as 125,000 m<sup>3</sup> which progressed to around 138,000 m<sup>3</sup> with Moss or membrane design – the volume restriction was largely the result of Japanese dominance of the industry and the need to conform to maximum displacement limits in Tokyo Bay.

### 2002

- There has been a gradual increase in vessel size to 155,000 m<sup>3</sup> and subsequently to 177,000 m<sup>3</sup>. Membrane vessels were preferred based, in part, on Suez Canal toll penalties for Moss vessels.
- These recent new build ships, however, are essentially the same as the conservative designs of the previous period but now optimised to achieve more within the same constraints.

### Post 2007

- The introduction by Qatar of the Q-flex (216,000 m<sup>3</sup>) and Q-max (up to 270,000 m<sup>3</sup>) vessels, on dedicated trades between Qatar and Italy, the UK and US, represents a radical change in the LNG shipping industry.
- The constraint now is water depth in the Persian Gulf. Everywhere else business will probably continue as normal with 140,000 - 177,000 m<sup>3</sup> vessels, or sub 75,000 m<sup>3</sup> for much of the Mediterranean.

## (d) How is LNG Regasified?

Pressurised LNG is vaporised by exchanging heat from a warmer medium into the cold LNG to regasify the liquid. The most common technologies used in the industry are open rack, sea water vaporisers (ORVs) and submerged combustion (fired) vaporisers (SCVs). Other technologies used are shell and tube vaporisers and air vaporisers.

### Open Rack Vaporiser (ORV)

Open rack vaporisers (ORV), using sea water as the heating medium, remain the lowest life cycle cost vaporisers for LNG and therefore the vaporiser of choice when water conditions and temperatures allow. However, environmental concerns over the damage the cold sea water and biocides do to fish, larvae and eggs have been raised in recent years.

### Submerged Combustion Vaporiser (SCV)

Submerged combustion vaporisers have been the traditional alternatives to ORVs. These vaporisers burn ~1.5% of their gas throughput to maintain a water bath, in which coils containing the LNG reside, at a constant temperature.

The increasing cost of gas has led to analysis of alternative methods of vaporisation to reduce revenue losses. Foremost of these has been the integration between the SCV and waste heat from a gas turbine exhaust used to warm water (instead of burning gas). This type of system has been successfully implemented in Europe.

The other 'free' energy source for vaporisation is air. The LNG can be warmed using an intermediate fluid such as propane or glycol and the fluid then warmed using the air. The first unit of this type at a worldscale LNG import terminal was installed at Dahej in India in 2004.

An alternative vaporisation process is to use the cold in an intermediate fluid to cool the air entering a combined cycle gas turbine (CCGT) power plant thereby increasing its power generation capability. This type of system has been installed at Ecoelectrica in Puerto Rico.



**Figure 4.20** – Open Rack and Submerged Combustion Vaporisers.

SCV image reproduced with permission of Selas Fluid (a Linde Company), Five Sentry Parkway East, Blue Bell, PA 19422

### (e) Offshore Regasification

An offshore LNG regasification terminal is, in simple terms, a facility that has the capability to vaporise LNG and send out high pressure natural gas from the vessel to shore. There are three major types:

- Floating.
- Gravity based structures.
- Platforms.

### Floating Terminals

There are two generic types of floating terminal:

- (a) A permanently moored vessel, either a new build or converted LNG carrier, to which an LNG carrier would offload its cargo of LNG directly into the storage tanks of the permanently moored vessel, i.e. a floating, storage and regasification unit (FSRU). The FSRU, as well as acting as a storage container, would also include the necessary regasification and send out equipment.
- (b) A sea-going regasification vessel (RV) where the ship becomes the terminal while unloading its cargo but is not permanently moored and, once its cargo has been discharged, is used as an LNG carrier to collect further cargoes.

### Sea-going Regasification Vessel (RV) – The Energy Bridge Vessels

Vessels where the ship becomes the terminal while unloading their cargoes are already in operation – Excelerate Energy operates several so called ‘Energy Bridge’ vessels. These vessels have demonstrated the general concept of offshore gas supply.

The Energy Bridge Regasification Vessels (EBRVs) are purpose built LNG carriers that incorporate onboard equipment for the vaporisation of LNG and delivery of high pressure natural gas. These vessels are capable of loading in the same manner to standard LNG tankers at traditional liquefaction terminals. EBRVs also retain the flexibility to discharge their natural gas cargoes in three different ways:

- Offshore as regasified LNG through a buoy which can be connected, through the bottom of the hull, to the front of the ship.
- Onshore as liquid at a conventional LNG receiving terminal.
- Onshore as regasified LNG through a high-pressure gas manifold located mid-ship.



**Figure 4.21** – Steam / seawater Vaporisers on Board the *Excelsior*.

(Reproduced with permission of Excelerate Energy)

### Gravity Based Structures (GBS)

Gravity based structures (GBS) are essentially a man-made island. They are more congested than onshore terminals typically 160 - 200m x 40 - 50m x 20 - 40m high. They use largely onshore technologies such as conventional pumps, vaporisers and unloading arms. However the LNG tanks used are of a ship type (membrane) and are incorporated below or adjacent to the other equipment within the concrete structure. Unloading is side by side and the structure provides some protection to berthed LNG carriers. There is a gas pipeline to shore.

An example of a GBS is Adriatic LNG's Rovigo terminal offshore of Northern Italy. However a GBS requires relatively shallow water (15 - 20m) to be cost effective, has no advantage in terms of schedule over onshore sites and claims on the effectiveness of a GBS as a breakwater have been challenged.

### Offshore Platforms

Platforms need relatively shallow water of 30 - 100m. Although much of the equipment can be placed on the platform, LNG storage tanks are too heavy and storage is generally by other means. The Freeport McMoran LNG platform had consent awarded in January 2007 after change to closed-loop vaporisers which were previously rejected due to the use of sea water for vaporisation. The project proposed to re-use sulphur mining platforms located 27 km offshore in the Gulf of Mexico and install a new platform for a small volume of LNG storage with most of the storage provided by salt domes adjacent to the existing platforms.





## Chapter 5

### Future Markets and Deregulations

Chapter 3 has identified the countries where gas quality specifications already exist or need to be developed. This chapter reviews the current international trading of liquefied natural gas (LNG) and the historical, growing and future markets for LNG. The worldwide capacities of both export and import facilities have been detailed to indicate current and future trading opportunities.

This chapter also describes the LNG gas quality from different sources. This is normally decided based on the field gas composition and trading requirements. Regional gas quality requirements are detailed here for comparison.

## 5.1 Where does LNG come from and go to?

- This section discusses the LNG trade movements according to the regional supply and demand requirements. Locations of the worldwide LNG liquefaction (export) and regasification (import) terminals are shown on a map.

## 5.2 Production Facilities Worldwide

- Middle East, Africa and South-East Asia are the three important regions for LNG production. Details for the LNG production facilities (current and those under construction) are included here.

## 5.3 Receiving facilities worldwide

- This section provides details for all LNG receiving facilities (current and those under construction).

## 5.4 LNG Gas Quality

- LNG producers decide on their LNG quality based on the field gas composition and more importantly, the market demands. This section discusses the range of LNG quality from different sources and also the regional gas quality requirements.

## 5.5 Deregulation of the LNG Chain

### 5.5.1 EU Gas Directives

- EU Gas Directives are creating an open internal market for natural gas. Details of the Gas Directives are provided here.

### 5.5.2 Liberalisation in LNG Trading

- The LNG industry has gone through liberalisation processes which affected the major players, contracts and regulations in the industry. This section provides a brief description on the evolution of the LNG industry, from the beginning to now.

### 5.5.3 Third Party Access

- Is Third Party Access to an LNG import terminal a regulated process? Further background, including the technical issues involved is examined here.

## 5.1 Where does LNG come from and go to?

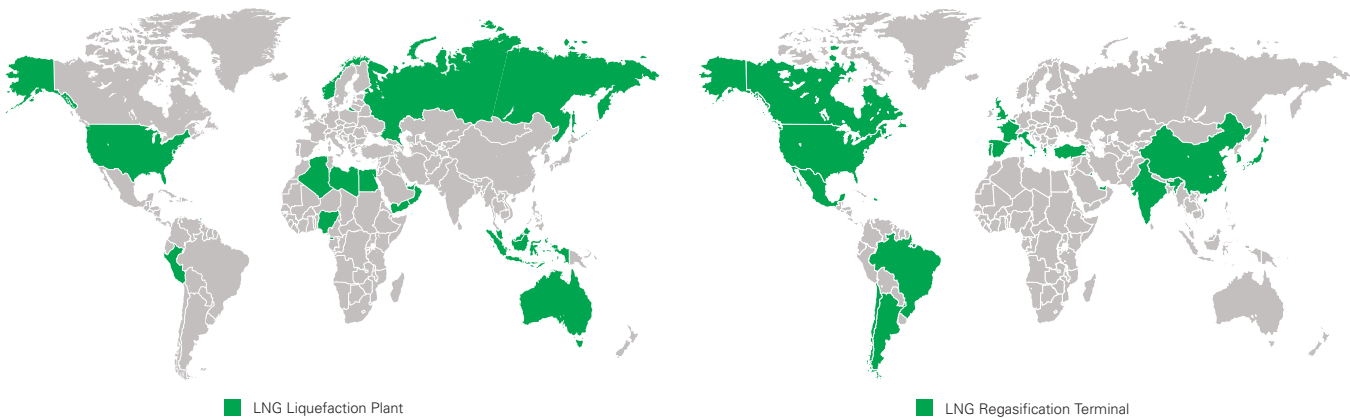
**Market demand for liquefied natural gas (LNG) is driven by declining indigenous supplies (Europe), fast market growth (South and Southeast Asia) and demands for gas for power generation. The Atlantic Basin (including Mediterranean) and Pacific Basin are the traditional LNG trading regions. The Pacific Basin often sees high traded volumes, high prices and rich gas compositions.**

Liquefied natural gas (LNG) primarily comes from areas where large gas discoveries have been made and no local market exists, such as Algeria, Brunei, Indonesia, Libya, Malaysia, Trinidad, Nigeria, Qatar, Oman, UAE, Egypt, Australia, Norway and Russia.

LNG trade has traditionally been split into two trading areas: the Atlantic Basin (including the Mediterranean) and the Pacific Basin. LNG has largely been shipped only within each market area. The markets have different characteristics:

- The Pacific basin is characterised by high traded volumes, high prices and rich (high Calorific Value) gas compositions. Japan remains the largest importer. Its volumes have stabilised in the recent years but rose in 2011 following the devastating earthquake and tsunami and the impact the tragic event had on the availability of Japan's nuclear powers stations. Regional growth has continued with South Korea and Taiwan increasing volumes, and India and China emerging as LNG importers.
- The Atlantic basin has a significant seasonal variation in traded volumes, lower prices to compete with pipeline gas and lean (low Calorific Value) gas compositions. LNG markets in the Atlantic basin have more liquidity than those in the Pacific basin.

Figure 5.1 shows a map of the world with the exporting and importing countries highlighted. Details of the location of the facilities are provided in Section 5.2 and Section 5.3 of this chapter.

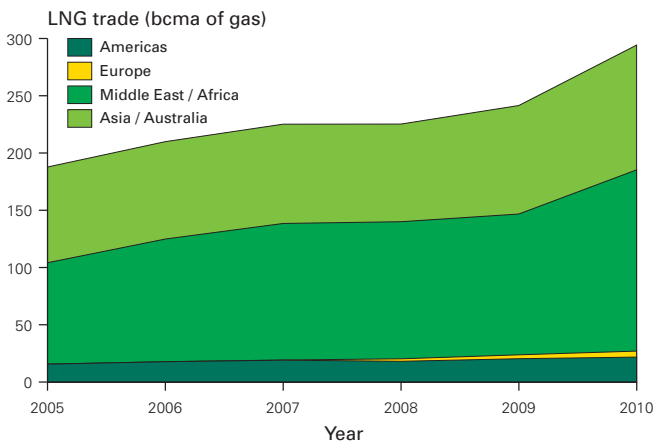


**Figure 5.1** – Importing and Exporting Countries.



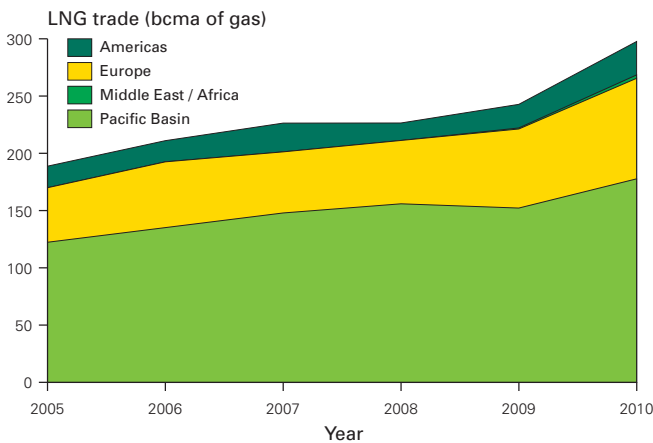
Historically, most liquefaction plants have been designed to serve clearly identified markets under long-term supply contracts. These contracts also specify the particular LNG quality parameters to be met by the plant in delivering to those local markets.

Figure 5.2 and Figure 5.3 show the regional and total growth in world LNG export and import trade.



**Figure 5.2 – World LNG Export Trade.**

Source: BP Statistical Review.



**Figure 5.3 – World LNG Import Trade.**

Source: BP Statistical Review.

**Table 5.1 – Summary of LNG Trade Movements for 2010 (mtpa).**

Source: BP Statistical Review.

To:	From:																				Total Imports
	USA	Trinidad & Tobago	Peru	Belgium	Norway	Russian Federation	Algeria	Egypt	Equatorial Guinea	Libya	Nigeria	Oman	Qatar	UAE	Yemen	Australia	Brunei	Indonesia	Malaysia		
<b>North America</b>																					
<b>USA</b>		5.38	0.45		0.76			2.07			1.18		1.29		1.10						<b>12.23</b>
<b>Canada</b>		1.59	0.08		0.08								0.25								<b>2.00</b>
<b>Mexico</b>			.26					0.16			2.23		1.02		0.18				1.87		<b>5.72</b>
<b>South &amp; Central America</b>																					
<b>Argentina</b>		1.63											0.15								<b>1.78</b>
<b>Brazil</b>	0.09	0.85	0.08						0.08		0.89		0.59	0.04							<b>2.78</b>
<b>Chile</b>		0.52					0.17	0.55	1.50				0.25		0.08						<b>3.07</b>
<b>Dominican Republic</b>		0.82																			<b>0.82</b>
<b>Puerto Rico</b>		0.77																			<b>0.77</b>
<b>Europe and Eurasia</b>																					
<b>Belgium</b>	0.05	0.08	0.08		0.09			0.17			0.16		5.80								<b>6.43</b>
<b>France</b>		0.35			0.51		6.27	0.73			3.57		2.43		0.08						<b>13.94</b>
<b>Greece</b>		0.08					0.98	0.08	0.03												<b>1.17</b>
<b>Italy</b>		0.32			0.16		1.61	0.72	0.09												<b>9.08</b>
<b>Portugal</b>		0.18			0.05						2.70		0.08								<b>3.01</b>
<b>Spain</b>	0.12	3.32	0.63	0.08	1.64		5.08	2.62		0.34	7.82	0.17	5.54		0.18						<b>27.54</b>
<b>Turkey</b>		0.26		0.08	0.26		3.87	0.27			1.26										<b>7.92</b>
<b>UK</b>	0.18	1.63			0.94		1.25	0.12			0.40		13.89		0.26						<b>18.67</b>
<b>Middle East</b>																					
<b>Kuwait</b>		0.33		0.09		0.09		0.33	0.29		0.08	0.91		0.25	0.09	0.09				0.24	<b>2.78</b>
<b>UAE</b>													0.16								<b>0.16</b>
<b>Asia Pacific</b>																					
<b>China</b>		0.07	0.08	0.08		0.51		0.08	0.08		0.17		1.61	0.08	0.70	5.21		2.45	1.68		<b>12.80</b>
<b>India</b>		0.66						0.09	0.17		0.33		10.53		0.37						<b>12.15</b>
<b>Japan</b>	0.85	0.15		0.08		8.23	0.08	0.57	0.72		0.84	3.80	10.15	6.86	0.16	17.66	7.78	17.00	18.55		<b>93.48</b>
<b>South Korea</b>		0.51			0.07	0.67		0.17	0.35		1.09	0.50	3.75	0.42		1.06		2.62	3.68		<b>14.90</b>
<b>Total Exports</b>	<b>1.64</b>	<b>20.38</b>	<b>1.82</b>	<b>0.57</b>	<b>4.71</b>	<b>13.40</b>	<b>19.31</b>	<b>9.71</b>	<b>5.16</b>	<b>0.34</b>	<b>23.90</b>	<b>11.49</b>	<b>75.75</b>	<b>7.90</b>	<b>5.48</b>	<b>25.36</b>	<b>8.83</b>	<b>31.36</b>	<b>30.54</b>		<b>297.63</b>

## 5.2 LNG Production Facilities Worldwide

### Regional LNG Supply and Demand Summary

#### USA – impact of shale gas on market

- The large supply shortfall that was predicted a few years ago, on the back of which many LNG import terminals were constructed, did not materialise. Large quantities of indigenous shale gas coming onto the market has suppressed the price of pipeline gas to 4 - 5 \$/mmBtu. As a result many proposed LNG terminal projects have been cancelled.
- Many LNG terminals are operating at very low utilisation rates. Some terminals, including Sabine Pass and Freeport, are developing projects to install liquification facilities, thereby enabling the terminal to liquify pipeline gas and export LNG to other markets.

#### Europe – A mixture of import and export

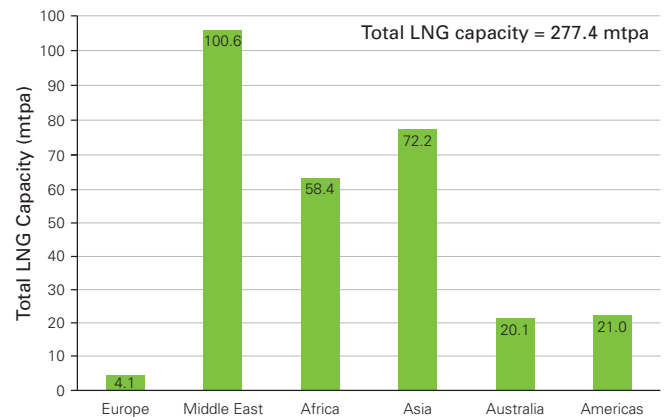
- Denmark, Norway and the Netherlands produce more natural gas than they consume.
- Dutch production is predicted to remain constant.
- The UK North Sea, German and Italian production are in decline, while Spanish and Italian gas markets are growing rapidly.
- Across Europe five more terminals are under construction and over 50 proposed.

#### LNG producers

- LNG producers are targeting the above markets, meaning that in the near future significant quantities of LNG produced from high-calorific value gas are likely to be unloaded in receiving terminals connected to low-calorific value gas pipeline networks.
- An exception is the new Qatar trains which are designed for low-Calorific Value gas, targeting European markets.

LNG is currently supplied from 18 countries and facilities in 25 separate locations.

### Supply of LNG by Region



**Figure 5.4** – Supply of LNG by Region.

Source: BP 2010.

Table 5.2 (overleaf) shows the currently operating liquefaction facilities worldwide.

**Table 5.2 – Operating liquefaction facilities worldwide.**

Source: GIIGNL LNG Industry Report 2010)

Country	Site	Liquification		Storage		Owner	Operator	Buyer	Start-up date
		No. of Trains	Nominal capacity (10 <sup>6</sup> t/yr)	No. of Tanks	Total capacity (m <sup>3</sup> )				
<b>Atlantic Basin</b>									
Algeria	Arzew GL 4Z	3	0.93	3	33,000	Sonatrach	Sonatrach	DEPA & GDF SUEZ	1964
	Arzew GL 1Z	6	8.19	3	300,000	Sonatrach	Sonatrach	GDF SUEZ, Botas, INI Gas & Power, Edison, Shell, Statoil, Endesa, DEPA, CEPSA	1978
	Arzew GL 2Z	6	7.98	3	300,000	Sonatrach	Sonatrach		1981
	Skikda - GL 1K	3	3.13	5	308,000	Sonatrach	Sonatrach	GDF SUEZ, DEPA, ENI Gas & Power	1972
Egypt	Damietta	1	5.00	2	300,000	SEGAS	SEGAS SERVICES	Gas Natural Fenosa, EGAS BP, BG & Petronas)	2005
	Idku	2	7.20	2	280,000	Egyptian LNG (EGPC, EGAS, BG, GDF SUEZ, Petronas)	Egyptian LNG (EGPC, EGAS, BG, GDF SUEZ, Petronas)	GDF SUEZ	2005
Equi	Bioko Island	1	3.70	2	272,000	Marathon, Sonagas, Mitsui, Marubeni	Marathon	BG Gas Marketing	2007
Libya	Marsa-el-Brega	3	0.60	2	96,000	Sirte Oil Co.	Sirte Oil Co.	Gas Natural	1970
Nigeria	Bonny Island	3	9.60	3	252,600	Nigeria LNG (NNPC, Shell, TOTAL, ENI)	Nigeria LNG Ltd	Enel, Gas Natural Fenosa, Botas, GDF SUEZ, Ren Atlantico	1999-2000
		2	8.10			Nigeria LNG (NNPC, Shell, TOTAL, ENI)	Nigeria LNG Ltd	BGLT-BGGM, Shell, Iberdrola, Endesa, Ren Atlantico, TOTAL, ENI G & P	2006
		1	4.00			1	84,200	Nigeria LNG (NNPC, Shell, TOTAL, ENI)	Nigeria LNG Ltd
Norway	Hammerfest	1	4.30	2	250,000	StatoilHydro, Petoro, Total, GDF SUEZ, RWE-DEA, Hess	StatoilHydro	Total, StatoilHydro, GDF SUEZ, Iberdrola	2007
Trinidad & Tobago	Point Fortin	4	15.10	4	520,000	Atlantic LNG (BP, BG, Repsol, GDF SUEZ, NGC)	Atlantic LNG (BP, BG, Repsol, GDF SUEZ, NGC)	GDF Suez, Gas Natural Fenosa, Repsol, BP, BG, NGC + various spot buyers)	1999
<b>Middle East</b>									
Abu Dhabi	Das Island	3	5.60	3	240,000	Adgas (ADNOC, BP, TOTAL, Mitsui)	Adgas	Tokyo Electric Power	1977
Oman	Qalhat	2	7.10	2	240,000	Oman LNG (Oman gvt, Shell, TOTAL, Korea LNG, Mitsubishi, Mitsui, Partex, Itochu)	Oman LNG	Kogas, Itochu, Osaka Gas, BP	2000
		1	3.60			Qalhat LNG (Oman gvnt, Oman LNG, Itochu, Mitsubishi, Union Fenosa Gas, Osaka Gas)	Oman LNG	Mitsubishi, Osaka Gas, Union Fenosa Gas	2006
Qatar	Ras Laffan (Qatargas 1 -T1 & 2)	2	6.40	4	340,000	QatarGas (QP, ExxonMobil, TOTAL, Marubeni, Mitsui)	Qatargas I	1997-98 (Chubu Elec), 1999 (Osaka Gas, Tokyo Gas, Toho Gas, Tohoku Elec, Kansai Elec, Chugoku Elec, Gas Natural)	1999
	Ras Laffan (Qatargas 1-T3)	1	3.10			QatarGas (QP, ExxonMobil, TOTAL, Marubeni, Mitsui)	Qatargas I	Tokyo Gas	1999
	Ras Laffan (Qatargas 2-T1)	1	7.80	8	1,160,000	(Qatar Petroleum, ExxonMobil)	Qatargas II	South Hook Gas	2009
	Ras Laffan (Qatargas 2-T2)	1	7.80			(Qatar Petroleum, TOTAL, ExxonMobil)	Qatargas II	South Hook, TOTAL Gas & Power Ltd	2009
	Ras Laffan (Qatargas 3-T1)	1	7.80			Qatar Petroleum, Conoco, Mitsui	Qatargas III	Conoco Philips, Repsol	2010
	Ras Laffan (RasGas 1 - T1 & 2)	2	6.60			RasGas 1 (QP, ExxonMobil, Kogas, Itochu, Nissho Iwai, LNG Japan)	RasGas I	Kogas, Distrigas, ... others (non GIIGNL members)	1999-2000
	Ras Laffan (RasGas 2 - T1)	1	4.70	6	840,000	Rasgas 2 (Qatar Petroleum, Exxon Mobil)	RasGas II	Petronet LNG	2004
	Ras Laffan (RasGas 2 - T2)	1	4.70			Rasgas 2 (Qatar Petroleum, Exxon Mobil)	RasGas II	Endesa, Edison	2005
	Ras Laffan (RasGas 2 - T3)	1	4.70			Rasgas 2 (Qatar Petroleum, Exxon Mobil)	RasGas II	Petronet, EDF, Distrigas, CPC	March 2007
	Ras Laffan (Rasgas 3 - T1)	1	7.80			Rasgas 3 (Qatar Petroleum, Exxon Mobil)	RasGas III	Petronet, KOGAS, Chevron, Sempra, Statoil	August 2009
Ras Laffan (Rasgas 3 - T2)	1	7.80	Rasgas 3 (Qatar Petroleum, Exxon Mobil)			RasGas III	Exxon, Kuwait Oil	April 2010	
Yemen	Balhaf - Train 1 & 2	2	6.70	2	140,000	Yemen LNG (TOTAL, Kogas, Yemen Gas Co., Hunt Oil Co., SK Corporation, Hyundai, GASSP1)	Yemen LNG	Kogas, GDF SUEZ, TOTAL Gas & Power Ltd	October 2009 & April 2010

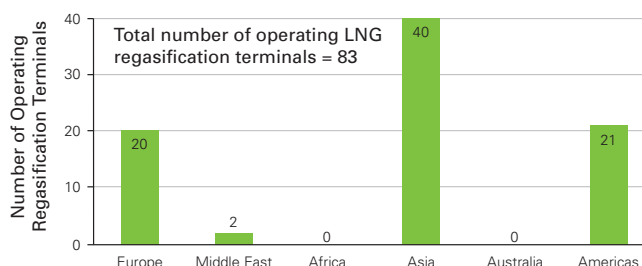
Table 5.2 – Continued

Country	Site	Liquification		Storage		Owner	Operator	Buyer	Start-up date
		No. of Trains	Nominal capacity (10 <sup>6</sup> t/yr)	No. of Tanks	Total capacity (m <sup>3</sup> )				
<b>Pacific Basin</b>									
Australia	Withnell Bay	4	12.10	4	260,000	NWS LNG JV (Woodside, Shell, BHP, BP Australia, Chevron, Mitsubishi/Mitsui)	Woodside	Tokyo Elec, Chubu Elec, Kansai Elec, Chugoku Elec, Kyushu Elec, Tokyo Gas, Osaka Gas, Shizuoka Gas, Tohoku Elec, Nippon Gas, Kogas, Shell Hazira Gas, DPLNG)	1989
		1	4.20	1	65,000	Woodsie, Shell, BHP, BP, Chevron_Australia, Japan LNG (16.67% each)	Woodside	Tokyo Elec, Chubu Elec, Kansai Elec, Chugoku Elec, Kyushu Elec, Tokyo Gas, Osaka Gas, Shizuoka Gas, Tohoku Elec, Nippon Gas, Kogas, Shell Hazira Gas, DPLNG)	2008
	Darwin	1	3.40	1	188,000	Darwin LNG (ConocoPhillips, ENI, Santos, Inpex, TEPCo, Tokyo Gas)	ConocoPhillips	Tokyo Electric, Tokyo Gas	2006
Brunei	Lumut	5	7.20	3	195,000	Brunei LNG (Brunei gvnt, Shell, Mitsubishi)	Brunei LNG Sdn Bhd	Tokyo Gas, Tokyo Electric, Osaka Gas, Kogas (1997)	1973
U.S.A.	Kenaï	2	1.40	3	108,000	ConocoPhillips, Marathon	ConocoPhillips, Marathon	Tokyo Gas, Tokyo Electric	1969
Indonesia	Blang Lancang - Arun	3	4.75	4	508,800	Pertamina	PT Arun NGL Co. (Pertamina, ExxonMobil, JILCO)	Tokyo Electric, Kogas (1986)	1978-1979
	Bontang - Badak	8	22.20						
	Bontang - Badak A & B	2						Kansai Elec, Chubu Elec, Kyushu Elec, Osaka Gas, Toho Gas, Nippon Steel Co.	1977
	Bontang - Badak C & D	2						Kansai Elec, Chubu Elec, Osaka Gas, Toho Gas	1983
	Badak E	1		6	630,000	Pertamina	PT Badak NGL Co. (Pertamina, VICO, TOTAL, JILCO)	C.P.C.	1990
	Badak F	1						Tokyo Gas, Osaka Gas, Toho Gas, Hiroshima Gas, Nippon Gas	1994
	Badak G	1						Kogas	1998
	Badak H	1						C.P.C.	1998
	Tangguh	2	7.60	2	340,000	Government of Indonesia	BP	Posco, K-Power, Sempra LNG, CNOOC Fujian LNG, Tohoku Elec	2009
Malaysia	Bintulu MLNG 1 (Satu)	3	8.10			Malaysia LNG Sdn Bhd (Petronas, Shell, Mitsubishi)	Malaysia LNG Sdn Bhd	Tokyo Gas, Tokyo Elec, Saibu Gas	1983
	Bintulu MLNG 2 (Satu)	3	7.80	6	445000	Malaysia LNG Dua (Petronas, Shell, Mitsubishi, Sarawak state Gvnt)	Malaysia LNG Dua	Tokyo Gas, Osaka Gas, Kansai Elec, Toho Gas, Shizuoka Gas, Tohoku Elec, Gas Bureau (city of Sendai), Saibu Gas, Kogas, CPC	1995
	Bintulu MLNG 3 (Satu)	2	6.80			Malaysia LNG Tiga (Petronas, Shell, Nippon Oil, Diamond Gas, Sarawak state Gvnt)	Malaysia LNG Tiga	Tokyo Gas, Osaka Gas, Toho Gas, Tohoku Elec, Japex, Hiroshima Gas, Kogas, CPC	2003
Peru	Peru LNG	1	4.45	2	260,000	Hunt Oil (50%), Marubeni (10%), Repsol YPF (20%), SK Corp (20%)	Hunt Oil	Repsol YPF	2010
Russia	Sakhalin 2	2	9.55	2	200,000	Sakhalin Energy Invest Co. (Gazprom, Shell, Mitsui, Mitsubishi)	Sakhalin Energy Invest Company	Gazprom Global LNG, Shell Eastern Trading, Kogas, Chubu Elec, Hiroshima Gas, Kyushu Elec, Osaka Gas, Saibu Gas, Toho Gas, Tohoku Elec, Tokyo Elec, Tokyo Gas	2009
<b>Total</b>		<b>94</b>	<b>269.58</b>	<b>91</b>	<b>9,155,600</b>				

## 5.3 LNG Receiving Facilities Worldwide

**There were a total of 83 LNG regasification terminals in operation worldwide (28 of which are in Japan) at the end of 2010, including 10 floating structures.**

Early LNG trade was primarily to Japan from the Pacific Rim and to Europe from North Africa. The world's first LNG import terminal opened in the UK in 1964, a 1.3 mtpa terminal at Canvey Island near London, UK. It was closed down in 1994 as a gas terminal and it is used as LPG (liquefied petroleum gas, a mixture of propane and butane) importation/exportation and storage terminal.



**Figure 5.4 – LNG Regasification Terminals by Region.**

**Table 5.3 – Summary of Operating LNG Regasification Terminals.**

Source: GIIGNL LNG Industry Report 2010)

Country	Site	Storage		Send out		Owner	Operator	TPA	Source of import	Start-up date
		No. of Tanks	Total Papa in cm (liq)	No. of Vapourisers *	Nominal capacity in NG bcm/y					
France	Fos-sur-Mer	3	150,000	15	5.50	Elengy	Elengy	Yes	Algeria, Egypt	1972
	Montoir-de-Bretagne	3	360,000	11	10.00	Elengy	Elengy	Yes	Algeria, Egypt, Nigeria, Norway, Qatar, Trinidad & Tobago, Yemen	1980
	Fos-Cavaou	3	330,000	4	8.25	Société du Terminal Méthanier de Fos-Cavaou	Elengy	Yes	Algeria, Egypt, Qatar	2009 (commercial operation from April 2010)
Spain	Barcelona	6	540,000	13	17.08	Enagas S.A.	Enagas S.A.	Yes	Algeria, Libya, Qatar, Nigeria, T&T, Egypt, Norway, Oman	1969
	Huelva	4	460,000	9	11.83	Enagas S.A.	Enagas S.A.	Yes	Algeria, Libya, Norway, Oman, Yemen, T&T, Nigerai, Qatar, Egypt	1988
	Cartagena	4	437,000	9	11.80	Enagas S.A.	Enagas S.A.	Yes	Algeria, Libya, Qatar, Oman, Nigeria, T&T, Egypt, Norway	1989
	Bilbao	2	300,000	4	7.00	Enagas, Repsol, Deutsche Bank, EVE	Bahia de Bizkaia Gas, SL (BBG)	Yes	Algeria, Egypt, Nigeria, Norway, T&T, Qatar, Oman	2003
	Mugardos	2	300,000	3	3.60	Gas Natural Fenosa, Endesa, Xunta Galicia, Sonatrach, Tojeiro Group, Galicia Government, Caixa Galicia, Pastor, Caixanova	Reganosa	Regulated T.P.A.	Algeria, Nigeria, T&T, Oman, Qatar	2007
	Sagunto	3	450,000	5	8.76	Gas Natural Fenosa, RREEF Alternative Investments, Endesa, Oman Oil Holding Spain	Saggas	Regulated T.P.A.	Algeria, Libya, Qatar, T&T, Nigeria, Oman, Egypt	2006
Italy	Panigaglia	2	100,000	4	3.32	GNL Italia S.p.A.**	GNL Italia S.p.A.**	Yes	Algeria, Qatar	1969
	Rovigo (Atlantic LNG)	2	200,000	5	8.00	Adriatic LNG	Adriatic LNG	Yes (20%)	Qatar	2009

**Table 5.3 – Continued**

Country	Site	Storage		Send out		Owner	Operator	TPA	Source of import	Start-up date
		No. of Tanks	Total Papa in cm (liq)	No. of Vapourisers *	Nominal capacity in NG bcm/y					
<b>Belgium</b>	Zeebrugge	4	380,000	11	9.00	Fluxys LNG	Fluxys LNG	Yes	Qatar, Egypt, Norway, T&T, Nigeria	1987
<b>Turkey</b>	Marmara Ereglisi	3	255,000	7	6.20	Botas	Botas	No	Algeria, Nigeria	1994
	Aliaga/Izmir	2	280,000	5	6.00	Egegaz	Egegaz	No	Algeria	2006
<b>Greece</b>	Revithoussa	2	130,000	6	5.00	Depa S.A.	Depa S.A.	No	Algeria	2000
<b>Portugal</b>	Sines	2	240,000	5	5.20	Ren Atlantico	Ren Atlantico	Yes	Nigeria, T&T, Equatorial Guinea	2004
<b>United Kingdom</b>	Isle of Grain	8	1,000,000	14	19.50	National Grid	Grain LNG	Yes (but no RTPA)	Algeria, Egypt, Qatar, T&T, Norway, Australia	2005
	Teesside	1	138,000		4.60	Excelebrate Energy			Trinidad & Tobago	2007
	Dragon	2	320,000	6	6.00	BG Group, Petronas, 4Gas	Dragon LNG	No	Trinidad & Tobago, Norway, Qatar, Nigeria	2009
	South Hook	5	775,000	15	21.00	Qatar Petr. LNG Services (QP), Exxon Mobil Qatargas Tml Co Lmted, ELF Petr. UK Lmted (TOTAL)	South Hook LNG Terminal Company Ltd	yes	Qatar	2009
<b>Canada</b>	Canaport LNG	3	160,000	8	10.00	Repsol Energy Canada (74.25%), Irving Canaport LP (24.75%), Repsol Canada (0.75%), Irving Canaport GP (0.25%)	Repsol Canada Ltd	Yes (but no RTPA)	Trinidad & Tobago, Qatar	2009
<b>USA</b>	Everett	2	155,000	4	6.90	Distrigas of Mass Co.	GDF SUEZ LNG North America	Yes	Trinidad & Tobago	1971
	Lake Charles	4	425,000	14	24.30	Trunkline LNG	Trunkline LNG	Yes	Nigeria, Egypt	1982, Infrastructure enhancement project completed March 2010
	Elba Island	5	535,000	11	16.30	Southern LNG	El Paso	Yes	T&T, Egypt	1978, restarted 2001, expanded 2006, expanded 2010
	Cove Point	5	380,000	10	10.74	Dominion Cove Point LNG	Dominion Cove Point LNG	Shell, BP, Statoil, Peakers 1/4 each	Trinidad & Tobago, Egypt	1978, restarted 2003
	Cove Point Expansion	2	320,000	15	8.00	Dominion Cove Point LNG	Dominion Cove Point LNG	Statoil Hydro	Norway	2008
	Gulf Gateway	1	150,000		4.60	Excelebrate Energy			Trinidad & Tobago	2005
	Northeast Gateway	1	150,000		4.60	Excelebrate Energy			Trinidad & Tobago	2008
	Sabine Pass	3	480,000	16	27.00	Cheniere Energy	Cheniere Energy	Total, Chevron, CMI	Qatar, Nigeria	2008
	Golden Pass	5	775,000		9.80	QP (70%), Exxon (17.6%), Conoco Philips (12.4%)	Golden Pass LNG		Qatar	2010
	Freeport LNG	2	330,694	7	18.00	Freeport LNG Development, L.P.	Freeport LNG Development, L.P.	Yes	Trinidad & Tobago, Egypt, Nigeria, Peru	2008
	Cameron LNG	3	480,000	10	15.50	Sempra	Sempra	Yes	Qatar, Trinidad & Tobago	2009
Neptune LNG	2	290,000		3.90	GDF SUEZ NA	GDF SUEZ NA			2010	
<b>Dominican Republic</b>	Punta Caucedo	1	160,000	2	2.32	AES Andres	AES Andres	No	Trinidad & Tobago	2003

Table 5.3 – Continued

Country	Site	Storage		Send out		Owner	Operator	TPA	Source of import	Start-up date
		No. of Tanks	Total Papa in cm (liq)	No. of Vapourisers *	Nominal capacity in NG bcm/y					
Mexico	Altamira	2	300,000	5	7.80	Terminal de LNG de Altamira (50% Shell, 25% Total, 25% Mitsui)	Terminal de LNG de Altamira	No	Nigeria, Egypt, Qatar, Trinidad & Tobago	August 2006
	Energia Costa Azul	2	320,000	6	10.33	Energia Costa Azul (100% Sempra LNG)	Energia Costa Azul	Yes	Indonesia, Qatar, Trinidad & Tobago	May 2008
Puerto Rico	Penueelas	1	160,000	2	3.75	EcoElectrica	EcoElectrica		Trinidad & Tobago	2000
Argentina	Bahia Blanca			6	3.00	Repsol YPF	YPF		Trinidad & Tobago, Egypt	June 2008
Brazil	Pecem**	1	129,000	2	2.50	Petrobras	Transpetro	No	Trinidad & Tobago, Nigeria	2009
	Guanabara Bay**	1	138,000	2	5.00	Petrobras	Transpetro	No	Trinidad & Tobago, Nigeria	2009
Chile	Quintero	3	344,000	3	3.65	GNL Quintero S.A.	GNL Quintero S.A.	No	Trinidad & Tobago, Qatar, Equatorial Guinea	2009
	Mejillones (FSU)	1	154,500	3	2.00	GNLM	GNLM	Yes	Yemen, Egypt, Trinidad	April 2010 (Phase 1)
Kuwait	Mina Al Ahmadi	1	150,000		7.07	KNPC	Excelerate Energy, KNPC		Australia, Malaysia, Russia	2009
China	Dapeng, Shenzhen	3	480,000	7	9.00	GDLNG	GDLNG	No	Australia, Qatar, Nigeria, Equatorial Guinea, Malaysia, Russia, Oman, Yemen, UAE, Indonesia	2006
	Fujian	2	320,000		3.70	Fujian LNG (CNOOC 60%, Fujian NV & Dev.Corp. 40%)	Fujian LNG	No	Egypt, Equatorial Guinea	2008
	Shanghai, Yangshan (Ximentang Isle)	3	495,000		4.10	Shanghai LNG (CNOOC 45%, Shenergy Grp (55%))	Shanghai LNG	No	Malaysia	2009
	Shanghai, Mengtougou	3	120,000		0.20	Shangai Gas Group	Shangai Gas Group		Malaysia	2008
India	Dahej	4	592,000	19	12.50	Petronet LNG	Petronet LNG	Yes (on a cargo by cargo basis)	Qatar, Algeria, Egypt, Australia, Oman, T&T, Nigeria,	2004, expansion in July 2009
	Hazira	2	320,000	5	3.40	Hazira LNG Private (74% Shell, 26% Total)	Hazira LNG Private Ltd	No		
Japan	Niigata	8	720,000	14	11.60	Nihonkai LNG	Nihonkai LNG	Yes	Indonesia, Malaysia, Qatar, Australia, Russia	1984
	Higashi-Ohgishima	9	540,000	9	18.00	Tokyo Electric	Tokyo Electric	Yes	Indonesia, Malaysia, Qatar, Australia, Oman, Abu Dhabi, Brunei, Russia	1984
	Futtsu	10	1,110,000	13	26.00	Tokyo Electric	Tokyo Electric	Yes	Indonesia, Malaysia, Qatar, Australia, Oman, Abu Dhabi, Brunei, Russia	1985
	Chita Kyodo	4	300,000	14	9.89	Toho Gas / Chubu Elec	Toho Gas	Yes	Indonesia, Malaysia, Australia, Qatar, Russia	1978
	Chita-Midorihamma Works	2	400,000	7	9.20	Toho Gas	Toho Gas	Yes	Indonesia, Malaysia, Australia, Qatar, Russia	2001
	Chita	7	640,000	11	15.70	Chita LNG	Chita LNG	Yes	Indonesia, Malaysia, Australia, Qatar, Algeria	1983
	Himeji	8	740,000	6	6.40	Osaka Gas	Osaka Gas	Yes	Indonesia, Malaysia, Australia, Qatar, Oman, Brunei	1984
	Himeji LNG	7	520,000	8	11.00	Kansai Electric	Kansai Electric	Yes	Indonesia, Malaysia, Qatar, Australia	1979
	Yanai	6	480,000	5	3.10	Chugoku Elec	Chugoku Electric	Yes	Australia, Qatar, Oman	1990
	Mizushima	1	160,000	3	1.30	Mizushima LNG	Mizushima LNG	Yes	Australia, Qatar, Oman	2006
	Oita	5	460,000	6	6.27	Oita LNG	Oita LNG	Yes	Indonesia, Australia, Russia, Algeria	1990
	Sakai	3	420,000	6	8.70	Kansai Electric	Kansai Electric	Yes	Indonesia, Malaysia, Australia, Qatar	2006



**Table 5.3 – Continued**

Country	Site	Storage		Send out		Owner	Operator	TPA	Source of import	Start-up date
		No. of Tanks	Total Papa in cm (liq)	No. of Vapourisers *	Nominal capacity in NG bcm/y					
Japan (cont)	Senboku I	4	180,000	5	2.94	Osaka Gas	Osaka Gas	Yes	Brunei	1972
	Senboku II	18	1,585,000	15	15.70	Osaka Gas	Osaka Gas	Yes	Indonesia, Malaysia, Australia, Qatar, Oman, Brunei, Russia	1977
	Tobata	8	480,000	9	10.28	Kita Kyushu	Kita Kyushu LNG	No	Indonesia, Australia, Russia, Equat. Guinea, Qatar	1977
	Yokkaichi LNG Centre	4	320,000	8	9.20	Chubu Electric	Chubu Electric	Yes	Indonesia, Qatar, Australia	1988
	Yokkaichi Works	2	160,000	4	2	Toho Gas	Toho Gas	Yes	Indonesia	1991
	Negishi	14	1,180,000	14	15	Tokyo Gas / Tokyo Electric	Tokyo Gas / Tokyo Electric	Negotiated TPA	Indonesia, Malaysia, Australia, Qatar, Brunei, Russia	1969
	Sodegaura	35	2,660,000	36	41.60	Tokyo Gas / Tokyo Electric	Tokyo Gas / Tokyo Electric	Negotiated TPA	Indonesia, Malaysia, Australia, Qatar, Brunei, Russia	1973
	Ohgishima	3	600,000	10	12.40	Tokyo Gas	Tokyo Gas	Negotiated TPA	Indonesia, Malaysia, Australia, Qatar, Russia	1998
	Fukuoka	2	70,000	7	1.10	Saibu Gas	Saibu Gas	Negotiated TPA	Malaysia	1993
	Sodeshi	3	337,200	8	3.90	Shimizu LNG	Shimizu LNG	No	Malaysia, Australia, Qatar, Nigeria, Indonesia, Russia	1996
	Hatsukaichi	2	170,000	4	1.15	Hiroshima Gas	Hiroshima Gas	No	Indonesia, Malaysia, Russia	1996
	Kagoshima	2	86,000	3	0.30	Nippon Gas	Nippon Gas	No	Indonesia, Australia	1996
	Kawagoe	4	480,000	4	7.10	Chubu Electric	Chubu Electric	Yes	Indonesia, Australia, Qatar	1997
	Shin-Minato	1	80,000	3	0.38	Gas Bureau	Gas Bureau, City of Sendai	No	Malaysia	1997
Nagasaki	1	35,000	3	0.20	Saibu Gas	Saibu Gas	Yes	Malaysia, Russia	2003	
Sakaide	1	180000	3	1.64	Sakaide LNG	Sakaide LNG	–	Malaysia	2010	
Korea	Pyeong-Taek	14	1,560,000	31	40.28	Kogas	Kogas	No	Indonesia, Malaysia, T&T, Brunei, Qatar, Oman, Egypt, Australia, Algeria, Nigeria, Equatorial Guinea	1986
	Incheon	20	2,680,000	33	40.99	Kogas	Kogas	No	Indonesia, Malaysia, T&T, Brunei, Qatar, Oman, Egypt, Australia, Algeria, Nigeria, Equatorial Guinea	1996
	Tong-Yeong	12	1,680,000	12	20.72	Kogas	Kogas	No	Indonesia, Malaysia, T&T, Brunei, Qatar, Oman, Egypt, Australia, Algeria, Nigeria, Equatorial Guinea	2002
	Gwangyang	3	365,000	2	2.30	Posco	Posco	No	Nigeria, Oman, Malaysia, Australia, Indonesia	2005
Taiwan	Yung-An	6	690,000	16	23.00	C.P.C.	C.P.C.	No	Indonesia, Malaysia	1990
	Taichung	3	480,000	6	9.00	C.P.C.	C.P.C.	No	Qatar	2009
<b>Total</b>		<b>363</b>	<b>38,506,394</b>	<b>646</b>	<b>795.5</b>					

\* Not including back-up capacity

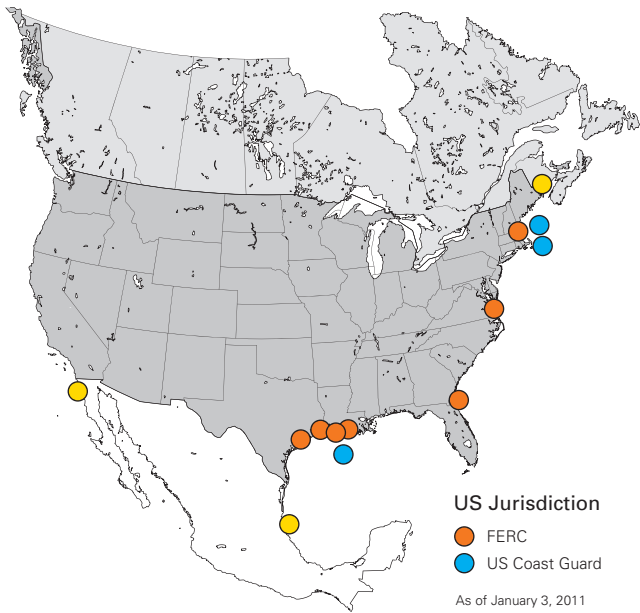
\*\* Floating Storage Regasification Unit - FSRU

\*\*\* GNL Italia is a wholly-owned subsidiary of Snam Rete Gas

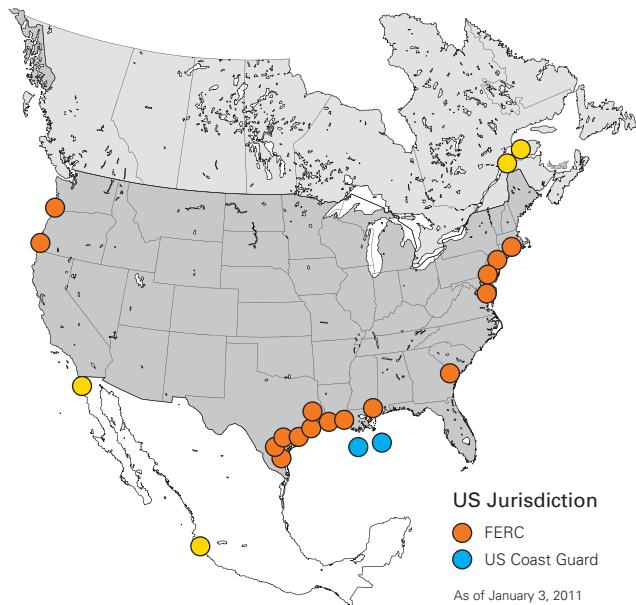
Figure 5.6 and Figure 5.7 show the locations of existing and proposed import terminals in North America, while Figure 5.8 shows the same for Europe.

**North America**

The yellow circles represent terminals outside the USA in Canada or Mexico.



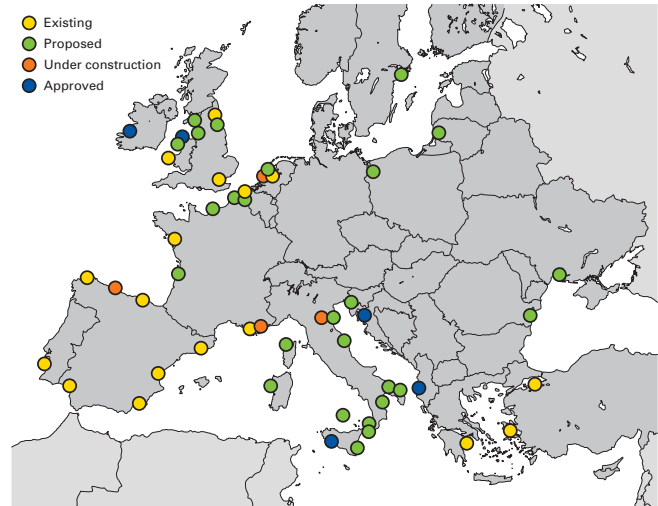
**Figure 5.6 – Existing North American LNG Terminals.**  
(Source: FERC)



**Figure 5.7 – Approved North American LNG Terminals.**  
(Source: FERC)

**Europe**

The circles in Figure 5.8 represent existing regasification terminals, the triangles those under construction and the circles are proposed terminals.



**Figure 5.8 – Existing, Planned and Proposed Import Terminals in Europe.**

## 5.4 LNG Gas Quality and International Requirements

### 5.4.1 Gas Quality Received from Liquefaction Terminals

**The leanest LNG is produced in Alaska's Kenai plant (almost pure methane) while the richest one is supplied by Libyan LNG. Most of the plants originally intended to serve the Asian market produce rich LNG with a Gross Calorific Value around 41.5 - 43.0 MJ/m<sup>3</sup> as shown in Figure 5.8.**

Producers face the following dilemma: "Is it better to produce a new lean quality LNG, together with rich LNG intended for Asian markets, which implies additional investment, or to produce only one LNG quality?" For the terminal operator the question is: "To what extent does it make sense to invest in nitrogen injection or LPG extraction units, in order to be able to receive LNG cargoes from many different suppliers?" Answering these questions is not easy and depends upon the particular situation of each company. Chapter 8 of the Guidebook sets out a strategy for considering the trading options for such situations.

Gas quality from different regions of the world is shown in Table 5.5. These are average figures which are representative of those received by import terminals (i.e. LNG has been weathered/aged so compositions are different from the production values).

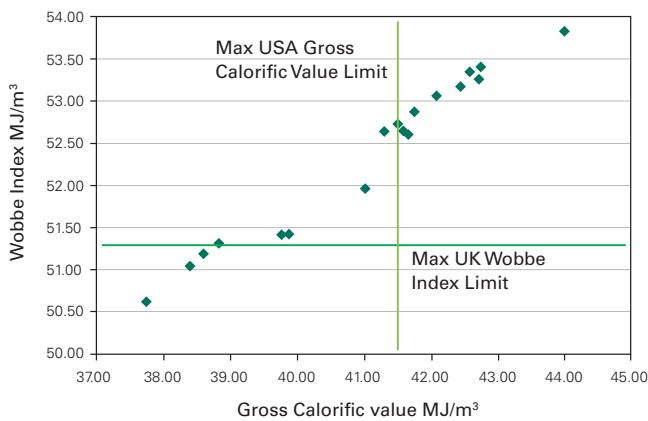
LNG composition varies widely between different sources. For example, LNG sourced from Alaska (Kenai plant) is extremely lean (almost pure methane with a low percentage of C<sub>3</sub>+ 's). Since LNG contains almost no carbon dioxide (as it is removed to avoid freezing during liquefaction) and has a low nitrogen content (i.e. as it is removed to avoid rollover problems), the leanest possible LNG is very close to pure methane, as at Kenai.

**Table 5.5** – Worldwide average LNG compositions: Basis 15°C metering and combustion, 1.01325 bar pressure.

	Nitrogen (%)	Methane (%)	Ethane (%)	Propane (%)	Higher Hydrocarbons (C <sub>4</sub> + %)	Gross Calorific Value (MJ/m <sup>3</sup> )	Wobbe Index (MJ/m <sup>3</sup> )
Algeria – Arzew	0.56	87.98	9.00	1.99	0.47	41.68	52.62
Algeria – Bethioua 1	1.20	87.59	8.39	2.12	0.70	41.01	51.96
Algeria – Bethioua 2	0.92	91.39	7.17	0.52	0.00	39.78	51.41
Algeria – Skikda	1.02	91.19	7.02	0.66	0.11	39.87	51.42
Egypt – Damietta	0.08	97.70	1.80	0.22	0.20	38.39	51.03
Egypt – Idku	0.00	97.20	2.30	0.30	0.20	38.61	51.19
Libya	0.69	81.57	13.38	3.67	0.69	44.02	53.82
Nigeria	0.08	91.28	4.62	2.62	1.40	41.76	52.87
Abu Dhabi	0.29	84.77	13.22	1.63	0.09	42.45	53.16
Oman	0.35	87.89	7.27	2.92	1.57	42.73	53.27
Qatar	0.36	90.10	6.23	2.32	0.99	41.58	52.65
Trinidad	0.03	96.82	2.74	0.31	0.10	38.82	51.29
USA – Alaska	0.17	99.73	0.08	0.01	0.00	37.75	50.62
Australia – NWS	0.09	87.39	8.33	3.35	0.84	42.74	53.40
Brunei	0.05	90.61	4.97	2.89	1.48	42.09	53.06
Indonesia – Arun	0.06	91.16	6.01	1.84	0.93	41.32	52.64
Indonesia – Badak	0.02	89.76	5.06	3.54	1.62	42.61	53.34
Malaysia	0.16	91.15	4.96	2.79	0.94	41.52	52.70

Algerian LNG is representative of a lot of existing liquefaction plants with relatively rich feeds, although four to five existing plants produce even richer LNG.

Many new liquefaction projects are being designed to produce a quality somewhere in-between the Kenai quality and the Algeria-Arzew quality to increase product acceptability.



**Figure 5.9** – Average GCV and Wobbe Index Received from Existing LNG Plants – Basis 15°C Metering and Combustion, 1.01325 bar Pressure.

### Regional Gas Quality Requirements



**Japanese** quality specifications very much reflect the fact that nearly all natural gas supplies arrive in the country as LNG. However, the LNG supplies have historically originated from Indonesia, Malaysia, Brunei, Australia, and Abu Dhabi (i.e. mostly

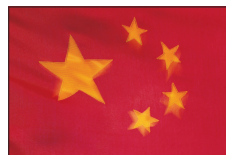
sourced from rich gas fields) and so Japanese specifications typically require LNG with a Heating Value and Wobbe Index that is higher than can be produced from gas fields with lower LPG content. In these cases, the imported LNG needs to be enriched with LPG. In addition, there are many different gas distribution networks in Japan and they are not generally interconnected. As a consequence, it is possible for each network to vary its specifications to meet the particular requirements of its gas consumers, although most companies use a common range of Wobbe Index.



**Korea** to a large extent has followed Japan, developing a LNG based gas quality standard but without LPG addition. Korea is planning, for the first time, to import gas by pipeline via China. The gas sourced from Russia is significantly leaner than

most LNGs. This gives Korea several options:

- add LPG to the pipeline gas but on a quantity basis this may be uneconomic;
- blend pipeline gas with LNG which is likely to be difficult given Korea's very high winter to summer load swings;
- widen the gas quality specifications to accommodate both LNG and pipeline gas in domestic and industrial use.



**China** has no standard for gas quality yet. It currently receives relatively rich LNG from the North West Shelf facility in Australia but will in future receive lean LNG from the Tangguh project in Indonesia. These LNGs have Wobbe Index of

around 54 MJ/m<sup>3</sup>. As most indigenous gas production is of similar Wobbe Index, this could determine the dominant (perhaps only) specification within China. To maintain access to a large variety of gas sources the specification limits may need to broaden further.



**India** represents a similar situation to China with no nation wide gas quality specifications. The LNG debate in India has so far been dominated by price rather than quality. Both LNG terminals at Dahej and Hazira have been importing a

wide range of spot cargoes of variable composition. Dahej has been extracting NGLs from the LNG but only as this represents a more profitable business than selling a rich LNG. The Indian government is currently considering overall gas quality standards but many commentators suggest that the calorific value range will remain broad to maintain energy growth and encourage a diverse LNG supply portfolio.



The various **European** gas quality specifications are different but broadly similar. Three groups of natural gases have been defined by EN 437 which specifies the test gases and pressures to be used when testing domestic gas

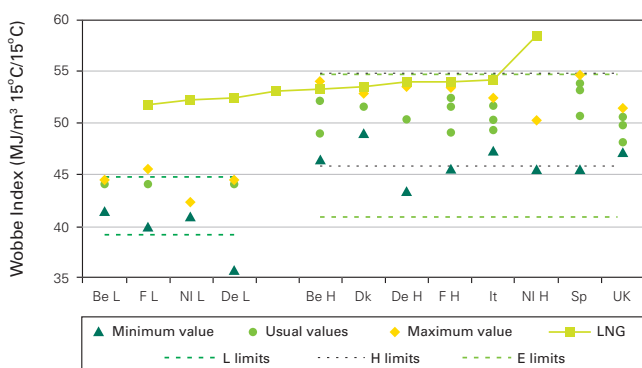
appliances for compliance with the Gas Appliance Directive. These categories are defined according to their Wobbe Index as follows:

**Group L:**  $39.1 < W < 44.8 \text{ MJ/m}^3$

**Group H:**  $45.7 < W < 54.7 \text{ MJ/m}^3$

**Group E:**  $40.9 < W < 54.7 \text{ MJ/m}^3$

Group L and H refer to low-calorific value and high calorific value gases available in countries in the Continental Europe. Specifically defined and used only in Germany and Luxembourg, Group E covers all of the Wobbe Index range of Group H and part of that of Group L. Each EU country has then defined their own limits within these categories for their different gas transmission systems. Examples of these are shown in Figure 5.10. The black dots represent the Wobbe Index of typical imported gas compositions into these countries and the red dots the Wobbe Index of LNG at its export point. It can be seen that not all LNG meets the Wobbe requirements. The Netherlands, UK and Italy are likely to need to process the import LNG to the national specifications.



**Figure 5.10** – European Gas Restrictions and Their Impact on Importation.

An organisation called EASEE-gas is leading efforts to harmonise these specifications, but realization of this goal is likely to take some time (further information in Chapter 3). An organisation of European terminal operators, GLNGE is working specifically to define LNG quality.



**UK** has a particularly onerous specification within Europe. This specification was originally developed when indigenous North Sea gas supplies were plentiful and so was not written with LNG in mind. As a consequence, gas entering the UK

distribution system needs to have a very low Wobbe Index and also needs to comply with two parameters that are unique to the UK called the Soot Index and the Incomplete Combustion Factor. These parameters measure the tendency of natural gas to generate soot or burn incompletely in domestic appliances (e.g. cookers, fires and central heating) and are necessary for the safe operation of older appliances supplied by the domestic gas distribution system. Most LNG is too rich for the UK gas market. LNG typically has a Wobbe Index that is too high to comply with the specification – see Figure 5.10. LNG may also have Incomplete Combustion Factor and Soot Index values that are too high to comply with the specification.



Only five liquefaction plants produce LNG which is suitable for the **USA** market. Unlike the UK and most of the rest of the world, which use Wobbe Index as a measure of gas interchangeability, pipeline specifications in the USA use Heating

Value. This is possible because butane, propane and usually ethane are removed from the natural gas for use in the petrochemical industry. This means that the gas supplied to end users in the USA typically has a Heating Value close to that of methane. The range of acceptable Heating Values varies between pipelines, but is lower than that of most LNG that is currently available. Exceptions to this are LNG from Trinidad, Egypt, Equatorial Guinea and some Algerian LNG; historically most of the LNG imports to the USA have come from these countries. The industry regulatory authorities are currently examining the use of other parameters to determine gas interchangeability, including Wobbe Index (see also Chapter 2 and Chapter 3).

## 5.5 Deregulation of the LNG Chain

### 5.5.1 EU Legislation

**The member states of the European Union have signed up to the Acquis Communautaire (the body of EU legislation). The Second Gas Directive is the key ruling for full marketing opening (by July 2007) although the progress on actual implementation is slow.**

Relevant EU legislation regarding the gas sector includes

- Commission Regulation No. 833/2010 of 21 September 2010 implementing Council.
- Regulation No. 617/2010 concerning the notification to the Commission of investment projects in energy infrastructure within the European Union.
- Regulation (EC) No. 663/2009 of the European Parliament and of the Council of 13 July 2009 establishing a programme to aid economic recovery by granting Community financial assistance to projects in the field of energy.
- Regulation (EU) No. 1233/2010 of the European Parliament and of the Council of 15 December 2010 amending Regulation (EC) No. 663/2009 establishing a programme to aid economic recovery by granting Community financial assistance to projects in the field of energy.
- Directive 2009/73/EC of the European Parliament and of the Council of 13 July 2009 concerning common rules for the internal market in natural gas and repealing Directive 2003/55/EC.
- Regulation (EC) No. 715/2009 of the European Parliament and of the Council of 13 July 2009 on conditions for access to the natural gas transmission networks and repealing Regulation (EC) No. 1775/2005.
- Commission decision 2010/685/UE of 10 November 2010 amending Chapter 3 of Annex I to Regulation (EC) No. 715/2009 of the European Parliament and of the Council on conditions for access to the natural gas transmission networks (Text with EEA relevance).
- Regulation (EU) No. 994/2010 of 20 October 2011 concerning measures to safeguard security of gas supply and repealing Council Directive 2004/67/EC.
- Directive 2008/92/EC of the European Parliament and of the Council of 22 October 2008 concerning a Community procedure to improve the transparency of gas and electricity prices charged to industrial end-users (recast) (text with EEA importance).
- Commission Decision 2003/796/EC of 11 November 2003 on establishing the European Regulators Group for Electricity and Gas repealed by:
  - Commission Decision 2011/280/EU of 16 May 2011 repealing Decision 2003/796/EC on establishing the European Regulators Group for Electricity and Gas.
- Regulation (EC) No. 713/2009 of the European Parliament and of the Council of 13 July 2009 establishing an Agency for the Cooperation of Energy Regulators (Text with EEA relevance).

- Directive 2009/142/EC of 30 November 2009 relating to appliances burning gaseous fuels laying out safety and performance requirements of common consumer and commercial appliances burning gaseous fuels.

The main legislation governing access to LNG terminals is contained within Directive 2009/73EC (The Gas Directive) and Regulation 715/2009 (The Gas Regulation) which together form part of the third internal energy market package.

Key aspects of this legislation cover:

- Promotion of competition.
- Non-discrimination.
- Interconnection and interoperability.
- Regulated access, negotiated access and exemptions.
- Unbundling.
- Transparency of access terms and utilisation.

As of October 2011, legal proceedings have been initiated against 18 member states for failure to implement in the provisions of the “Third Package” inside the legally required time.

## 5.5.2 Developments in LNG Trading

**LNG is increasingly traded in response to price differentials between regional markets. Although some long term supply contracts still exist, diversions for commercial reasons are increasingly common. Regulation largely focuses on the availability of capacity at LNG regasification terminals, and means of ensuring that lack of access does not contribute to barriers to entry in supply.**

With the decline in indigenous production in some areas of the world, and with new unconventional sources of gas in other areas leading to a surplus, different regions of the world can experience very different supply/demand balances. Increasingly, LNG deliveries and diversion of LNG cargoes enables market solutions to resolve these surplus and shortfall conditions. This in turn has led to increasingly liquidity in the traded LNG market, in shipping, and in access to LNG regasification terminals.

Where LNG is part of the supply base in a particular region, it can also provide a means to enter the market, if new suppliers are unable to obtain pipeline gas or capacity. LNG also allows new regions which are not currently located on pipeline routes to gain access to a gas supply.

However, it must be recognised that LNG cargoes are not an entirely homogeneous product. Larger tankers may not be able to land cargoes at smaller terminals, or may simply not be registered to do so. Rich gas that is destined for Japan may only be able to be landed at terminals in Europe that can provide the necessary ancillary facilities of blending or ballasting. If a cargo redirection requires significant additional shipping times, then this may not be available. Finally, cargoes tend to be large and can not easily be monetised by small players in illiquid markets.

For these reasons, the LNG market tends to be populated by large traditional players, and deals are negotiated bilaterally on special terms, rather than traded through exchanges.

There are additional difficulties when parties must share a regasification terminal and have some means to convert a short period of deliverability into a product that can be traded or delivered in a manageable profile to users. This typically requires either terminal sharing arrangements, or a liquid swaps market, or access to storage or a liquid traded market.

Attempts have been made to develop common contractual arrangements for trading, but none has yet become universal.

### Changes in LNG Trading

Traditional LNG contracts focused on security of supply for the buyer. Features of these contracts include

- Long-term (often 20 - 25 years).
- Rigid with take-or-pay clause and delivered ex-ship in designated tankers.
- Destination clause which specifies the country (or even terminal) to which LNG has to be delivered.

This was not usually a problem in regulated markets where costs could be passed on to the customers and buyer had a monopoly position. However, with market deregulation, buyer loses his monopoly position and becomes more interested in LNG trading to manage demand variations. EU has outlawed destination clauses as a restriction on free trade.

Emergence of short term LNG markets (down to individual or part-cargoes) is a result of this change. There are several factors to drive the short-term market:

- New plants are being built without committing the full capacity.
- Increasing demands for LNG in Spain, UK, Korea, Japan, South America, etc.
- Availability of ships that are not committed to projects.

**Table 5.6 – The Evolution of the LNG Chain.**

	The Beginning: 1964 - 1995	The Middle Years: 1995 - 2005	Now: 2005 +
<b>Driving forces</b>	Security of supply.	<ul style="list-style-type: none"> <li>• Alternative fuel for combined-cycle gas turbine (CCGT).</li> </ul>	<ul style="list-style-type: none"> <li>• Arbitrage opportunities.</li> <li>• Declining indigenous production in EU.</li> <li>• Potential to export unconventional gas from North America.</li> <li>• Security of supply.</li> </ul>
<b>Major Players</b>	<ul style="list-style-type: none"> <li>• National gas/electricity companies.</li> <li>• International/national oil companies.</li> </ul>	<ul style="list-style-type: none"> <li>• Dominated by the previous players.</li> <li>• Independent power producers also in business.</li> </ul>	<ul style="list-style-type: none"> <li>• Rising roles of National oil companies in production.</li> <li>• International oil companies starting to dominate transportation/importation.</li> </ul>
<b>Characteristics</b>	<ul style="list-style-type: none"> <li>• Simple, basic concept for production and supply of LNG.</li> <li>• Known LNG quality.</li> <li>• "Take or pay" contract.</li> </ul>	<ul style="list-style-type: none"> <li>• Remained long term and limited flexibility.</li> </ul>	<ul style="list-style-type: none"> <li>• Spot cargoes selling to the highest bidder.</li> <li>• Different terminal design amidst the concerns about gas quality regulations.</li> <li>• Banks/utilities entering traded markets.</li> </ul>

### 5.5.3 Third Party Access

**Regulated third party access to a LNG import terminal is the default in Europe, although many countries, for example the UK, have granted exemptions from the requirement, buy agreement with the national regulatory authority and the European Commission. New terminals constructed as part of an upstream project and merchant terminals have mostly been granted exemptions.**

Under both USA and European legislation, regasification facilities, like other gas infrastructure, are subject to third-party access. This means that companies who construct terminals have to offer capacity to other possible users, including competitors.

The issue of whether Third Party Access policies should be applied to LNG terminals is often expressed as a trade-off:

- Third Party Access promotes gas-on-gas competition in an open market, giving LNG buyers and gas suppliers choices to purchase spot cargoes.
- Third Party Access may discourage LNG import terminals projects. These projects are capital intensive and cannot be justified without secured returns/incomes. Third Party Access increases the risks associated with import terminal projects making it harder to finance.

Exemptions from Third Party Access may be granted if certain conditions are met. In Europe, national regulators are empowered to grant exemptions from the Gas Directive's Third Party Access stipulations, but these can be overruled by the European Commission.

The commercial arrangements for Third Party Access are crucial in ensuring that no participant in the terminal is advantaged or disadvantaged compared to any other, often regardless of their investment or throughput in the terminal. There are some technical issues that would arise from these contractual forms:

- How much LNG storage should there be? This is the key determinant of the terminal's economic viability. In order to minimise the storage inventory considerable discussions are required between owner and shippers along with modelling of the gas nominations regimes to show that the smaller storage volume can handle all the shippers' requirements.
- How much regasification/gas export capacity should there be? All the shippers want the rights to send out when the market price peaks and none of them wish to send out when it is at its nadir. Although regasification is relatively inexpensive and extra capacity can be justified, the commercial rules may need to be written to include pro-rata rules.
- How can the berth availability be maximised? This is often a difficult issue. The delay profiles on LNG ships using the terminal are beyond the control of the terminal owner and the need for a second jetty may become a critical issue.









## Chapter 6

### Impact on End Users

Downstream processes involving combustion (industrial, commercial and domestic systems) are “tuned” and optimised for specific fuel types or compositions. There is a range of fuel compositions that will be acceptable for use in these processes but this may be a narrow range compared to the gas supply variation.

Several methods can be used to accommodate the gas composition variation but often the equipment has to be operated in a non-optimum manner. This typically increases operating costs and can also lead to reliability, efficiency, operability and emission issues.

Interchangeability impacts are dependent on combustion technology employed in the various operational plants. Burners and combustion systems that employ complex control systems and advanced technology for lower emissions or improved efficiency are often the systems that cannot accept a wide variation in fuel gas composition. Less efficient, simpler designs can often accommodate wider variation in gas quality but with significant impact on emissions and overall process control/optimisation.

This chapter will review the downstream impacts of variation in gas quality on a range of types of combustion systems.

## 6.1 Background

- This section provides a general introduction to the impacts of gas quality variation on the combustion characteristics of gas-fired equipment. This also includes a brief indication of the adaptability of this equipment to gas quality changes.

## 6.2 Gas Burners

- What are the impacts of high Wobbe Index gas on burner efficiency and emissions? How is a burner control system designed? These are explained along with case studies for the impacts on domestic and industrial burners.

## 6.3 Gas Turbines

- Conventional and modern burners for low emissions are tuned differently to give satisfactory emissions profiles. The gas composition implications on flame, emissions and combustion characteristics are investigated. Case studies are included to illustrate the effect of higher hydrocarbon content and catalytic combustion systems for gas turbines.

## 6.4 Engines

- Engines could suffer performance losses, increased emissions or even serious damage when operated with different gas compositions. The impacts on system integrity, engine performance and emissions are studied in this section. A case study examining the impacts of propane-air addition in North America is also included.

## 6.5 Flame and Temperature Controlled Manufacturing Processes

- Metal reheating and glass production are examples of processes where changes in gas composition can have serious impact. This section focuses on the implications in the glass fibres and television tube manufacturing industries.

## 6.6 Chemicals – Methane Steam Reforming

- This is an example of natural gas used as a feedstock in the chemical industry. The methane steam reforming process produces hydrogen from methane. More details for the gas quality impacts on products and operating conditions are outlined in this section.

## 6.1 Background

**Gas-fired equipment demonstrates different levels of tolerance to the variation of gas composition, depending on the system sensitivity and design tolerance to parameters such as emissions and combustion efficiency. Rapid or transient changes in gas composition are particularly problematic for some combustors (e.g. in gas turbines).**

**Although Wobbe Index is commonly used to define a combustion process, many other parameters have been adopted for specific applications, to reflect the individual requirement (e.g. Octane Rating for vehicle engines).**

Natural gas is used widely in industrial and commercial applications both as a fuel source and a chemical feedstock. Natural gas can be a fuel for a gas turbine or engine for electricity or power production, in a boiler for steam or hot water production, and in a furnace for process heating/melting/etc.

In many instances, the degree of Wobbe Index (WI) variation affects the combustion process only marginally, and is often within the boundaries of normal control variations. However, in some process industries, even these small variations can cause significant process upsets if not adequately controlled.

### Burner Types

In industrial and commercial burner systems both diffusion and premixed flames are used and the preferred type depends on the requirements of the overall process. The burner types using the premixed and diffusion flames are varied but can be broadly classified into five types:

- Diffusion flame or post-aerated burners (no premixed air/gas).
- Atmospheric burners (entrained combustion air)
- Air-blast burners.
- Nozzle-mix burners.
- Specialist burners such as pulse combustors or catalytic burners.

Gas quality and composition variations have a direct impact on combustion characteristics and may result in incorrect operation of the system or a detrimental effect on the product. The magnitude of the impact depends on the application and the burner (and control) system. There may be the following impacts:

- Unstable combustion.
- Higher pollutant emissions.
- Lower efficiency.
- Ignition problems.
- Thermo-acoustic problems.

Different types of gas-fired equipment and the relevant gas quality issues are summarised in Table 6.1.



Generally, standard burners with forced draught fans for air supply are not very sensitive to modest changes in gas Wobbe Index. If the Wobbe Index drops then the burner control system ensures that the overall heat input is maintained. However, domestic burners are subject to a narrower window of Wobbe Index to meet the emission safety requirements. Combustion of off-specification gas could lead to toxic emissions.

The control systems installed on gas turbines are more sophisticated than conventional burner systems and can accommodate some fuel quality variation, although the emission profiles would be changed. However, modern premixed burners for DLN (Dry Low NOx) or DLE (Dry Low Emission) are often less tolerant of changes in fuel gas composition.

The performance and emissions of spark-ignition engines are very sensitive to the variations in gas composition, depending on good ignition, optimum combustion rate, adequate knock resistance and a controlled energy content of the fuel mixture.

This chapter investigates the impacts of gas quality on various downstream natural gas applications, including:

- Combustion applications – for gas burners (Section 6.2), gas turbines (Section 6.3), engines (Section 6.4) as well as flame and temperature controlled manufacturing processes (Section 6.5).
- Non-combustion applications – using the example of natural gas as feedstock for the methane steam reforming process (Section 6.6).

### Diffusion Flame Combustion and Lean Premixed Combustion

In diffusion flame combustion, fuel and air are introduced in separate passages, and the flame is stabilised where the fuel and air streams mix. This type of combustion typically happens very fast at near stoichiometric condition.

Diffusion flame combustion generally has high flame temperature, enough to oxidise nitrogen in air. This makes it difficult to reduce oxides of nitrogen (NOx) emissions.

Lean premixed combustion (DLN/DLE) pre-mixes the fuel and compressed air so that there are no local “hot-spots” of high temperatures. Excess air is provided to dilute the combustion and keep the flame temperature low enough to avoid thermal NOx formation. The combustor, however, must operate in a very narrow range of Equivalence Ratio ( $\phi$ ), to avoid blowout at  $\phi < 0.5$  and NOx formation at  $\phi > 0.6$  (typically).

Reference: (EPRI report “Tuning approaches for DLN combustor performance and reliability” Report 1005037. March 2005)

**Table 6.1 – Gas-fired Equipment and Gas Quality Issues.**

	Concerns	Control Parameter	Sensitivity to Gas Quality Changes
<b>Domestic burner</b>	<ul style="list-style-type: none"> <li>• Significant appliance population without in-built pressure regulation or sophisticated controls</li> </ul>	<ul style="list-style-type: none"> <li>• Wobbe Index</li> </ul>	<ul style="list-style-type: none"> <li>• High</li> </ul>
<b>Commercial /industrial burner</b>	<ul style="list-style-type: none"> <li>• Wide range of use</li> <li>• Efficiency</li> <li>• Emissions</li> </ul>	<ul style="list-style-type: none"> <li>• Wobbe Index</li> <li>• Calorific Value</li> </ul>	<ul style="list-style-type: none"> <li>• Low – medium</li> </ul>
<b>Gas turbine</b>	<ul style="list-style-type: none"> <li>• Efficiency</li> <li>• Emissions</li> <li>• Turbine life</li> </ul>	<ul style="list-style-type: none"> <li>• Wobbe Index</li> <li>• Modified Wobbe Index</li> <li>• Gas Index</li> <li>• Fuel Index</li> </ul>	<ul style="list-style-type: none"> <li>• Low – high</li> </ul>
<b>Engine</b>	<ul style="list-style-type: none"> <li>• Knock</li> <li>• Efficiency</li> <li>• Emissions</li> <li>• Stable combustion</li> </ul>	<ul style="list-style-type: none"> <li>• Wobbe Index</li> <li>• Methane Number</li> <li>• Octane Rating (MON or RON)</li> </ul>	<ul style="list-style-type: none"> <li>• High</li> </ul>

## 6.2 Gas Burners

---

**Burner noise, flame stability and mixture ignitability can all be altered by the variation of gas composition but the main impact is on pollutant emissions. This is linked to the efficiency as a consequence of the change in the air-to-fuel ratio or stoichiometry of the mixture.**

**The burner control systems can be designed at low to high levels according to the desired degree of control, which could be a simple “On-Off” type control or may involve complex process demands for heat and temperature.**

---

The variation of gas composition can affect burner performance and operation. The air-to-fuel ratio for simple burner control systems is a constant set point and often assumes that the gas used has a constant calorific value or Wobbe Index. The values of these constants will be set for a typical burner to give about 10% excess air under normal conditions.

As explained in Chapter 2, Wobbe Index is Gross Calorific Value (or High Heating Value) divided by the square root of relative density of the gas, and accounts for the impact of gas density on the fuel flow through a nozzle. However, in the gas burners industry, Calorific Value is more widely used than Wobbe Index for process control. This is mainly due to the relatively crude control system that operates on a volumetric basis (instead of a mass or energy basis).

If a higher Wobbe Index gas is fed to the burner, this could result in:

- Loss of efficiency. At the preset air-to-fuel ratio, higher Wobbe Index feed gas will cause incomplete combustion due the lack of oxygen. This directly reduces the output energy and results in loss of combustion efficiency.
- Substantial carbon monoxide emission as the burner operates at significantly reduced excess air.

If a lower Wobbe Index gas is fed to the burner, this could result in:

- Changes to the pollutant emission levels as the level of excess air increases substantially.
- Loss in overall efficiency. Lower Wobbe Index gas will cause an increase in oxygen level in the flue (exit) gas. An empirical relationship exists that states:  
“For each percentage point of oxygen above the optimum in the flue gas, there is a 1 - 1.5% increase in fuel consumption!”  
Any increase in fuel consumption can be directly related to a loss of overall efficiency.
- Flame blow-off as the burning velocity of the flame at high excess air is substantially lower than for normal operation.

Some of the operability issues relating to ignition, efficiency and operation of safety devices do not appear to be compromised with increase in the Wobbe Index. However, more significant changes occur with regard to appliance emissions of carbon monoxide and NO<sub>x</sub>.

Older burner designs appear to be less sensitive to changes in gas quality but do show some increase in emissions with increase in Wobbe Index.

### Burner Control Systems

Control systems for burners, developed to ensure that the burner is operating safely, can accommodate some changes in fuel gas composition. The measurements made for flame detection can be compromised with change in the flame envelope due to change in the gas composition. The result could be a “trip” of the overall system, with a resultant impact on plant operation, throughput and costs.

From a process performance viewpoint, the following factors need to be considered:

- **Temperature control** – typically, an industrial process requires operation at a particular temperature to ensure that the “product” is of the desired quality.
- **Heating rate** (impact of load or demand) – to maintain specified process conditions it is often necessary to control the heating rate and the heat input to a burner. This is often linked to overall temperature control.
- **Combustion efficiency** – although the most efficient use of fuel is to combust it with the stoichiometric amount of air, in practice this is not the target operation as natural process variability results in incomplete combustion and an increased potential for toxic carbon monoxide emission.

### Burner Control Systems

Control systems can be very complex and involve signal feedback or feed forward to provide information on the overall operation. There are several levels of control and several methods, the complexity of which depends on the degree of control required. At a “high level”, there are process demands for heat, temperature, steam, etc. These may be simple “On-Off” type controls. Other “lower level” controls may act on “real-time” measurements to provide “fine-tuning” of the overall control process. The temperature demand may also be in the form of a response curve, dictating the time-dependence of the desired temperature profile for the process.

### Case Study 6.1 Industrial/Commercial Burners and Systems

The Gas Technology Institute (GTI) investigated the impact of gas quality changes on the operation of several types of industrial and commercial burners. Several tests were conducted on radiant panel burners, radiant tube burners and a traditional ribbon burner. Although the studies have considered overall process operability and reliability, the main focus was on emissions variation with increase in Wobbe Index of the gas supplied.

Table 6.2 summarises the general trends observed:

**Table 6.2** – Impact of Wobbe Index on Different Types of Burners.

Burner type	Rating (btu/hr)	Impact of increasing Wobbe Index	
		Carbon monoxide emission	NO <sub>x</sub> emission
Radiant panel burner	100,000	Approximately constant	Approximately constant
Radiant tube burner	Not known	Increases	Decreases
Ribbon burner	Not known	Constant or slight decrease	Increases

Reference: D. Rue and Y. Chudnovsky (Gas Technology Institute) presentation to CEC Stakeholders Group, Sacramento, CA. October 29, 2007. entitled "Overview of Commercial Burner Test Program With Early Results"

### Steam Boiler/Power Plant Owners/Operators

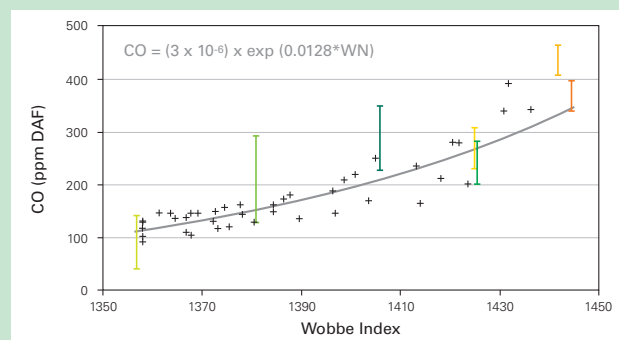
Natural gas is used in several large combustion plant designs and types. Typically there are no significant issues regarding change of Wobbe Index as the control system/forced draft fan arrangement typically has sufficient margin to accommodate increases to Wobbe Index. Two thermal power station owners/operators have commented that there are issues regarding mercury levels in gas. This problem is associated with emissions legislation compliance rather than operational difficulties. This problem, however, is not anticipated with regasified LNG as mercury is removed completely upstream of the LNG liquefaction process.

### Case Study 6.2 Impact on Domestic Appliances

With reference to Section 2.2.2 and the "UK Appliances Test Programme", independent studies were carried out by DTI (Department of Trade and Industry) in the UK and GTI in the USA, focusing on emissions and operability of appliances on a range of gas qualities. The studies concluded that there is not a definitive appliance response relating to changes in gas quality. Some burners and appliances display trends of increasing emissions whereas other show flatter response.

Both the UK and USA studies on domestic appliances highlighted the impact of initial start-up of the appliance where transient emission spikes are often observed. Here the appliance is starting from cold and acts to quench the combustion process resulting in higher than normal emissions of carbon monoxide. As the Wobbe Index increases the magnitude of the emission spike can increase for some appliances.

The consistent trends observed in both the USA and UK provide a strong argument that the impacts of gas quality are real and substantial. The data have been used to assist in developing a larger scale Europe-wide project to further investigate the effects of gas quality on domestic and commercial appliances and this project should begin in the near future.



**Figure 6.1** – Impacts of Wobbe Index Changes on Carbon Monoxide Emissions.

The above chart shows the impact on the emissions of carbon monoxide as a function of Wobbe Index, from the USA appliance studies.

References:

- (a) "UK Appliances Test Programme", DTI, UK. (see web site: <http://www.berr.gov.uk/energy/markets/gas-markets/gas-quality/phase-2/page21044.html>).
- (b) Brett C. Singer, "Appliance Emissions and Air Quality Impacts of LNG", Lawrence Berkeley National Laboratory, USA. ([http://www.energy.ca.gov/pier/papers\\_presentations/2007-10\\_29\\_pier\\_natural\\_gas\\_workshop/](http://www.energy.ca.gov/pier/papers_presentations/2007-10_29_pier_natural_gas_workshop/))

## 6.3 Gas Turbines

**Modern, premixed burners show lower tolerance to changes in fuel gas composition compared to traditional burner systems due to a narrow design fuel range to meet emissions profiles.**

**Gas turbines typically use fuel gas heating to prevent dewpoint liquid drop-out problems. As temperature becomes an important parameter, Modified Wobbe Index (MWI) has been derived and is often used to take into account fuel temperature.**

**On top of the emissions issues, other impacts of gas composition on gas turbines may include flame failure and burner instability problems like flash-back, auto-ignition, combustion dynamics, vibration and noise.**

The emissions profiles of premixed burners for DLN or DLE are optimised for a specific range of fuel qualities and if the fuel delivered to the gas turbine is outside of this range then emissions will almost certainly be higher. This is of major concern if the plant is operating close to any imposed, legislated emissions limits.

Combustor exhaust temperatures in such systems can be as low as 1750K and tests have shown that flame-out can be a problem if the temperature drops to around 1600K.

- Sudden drops in Wobbe Index can reduce the temperature and cause problems for the combustor.
- Increases in the Wobbe Index can increase the temperature and may result in thermo-acoustic problems within the system.

Some gas turbines have Calorific Value or Wobbe Index measurement of the fuel supply and the value is used in the sophisticated control systems for such machines.

### Gas Quality and Gas Turbines

Gas turbine manufacturers tend not to openly publish turbine operational problems related to gas quality. Contracted fuel specification for gas turbines is negotiated and performance guarantees are only provided for the quoted fuel quality General Electric (GE) generally quote a MWI range of 5% and state that GE must analyse and approve all conditions where the 5% variation is to be exceeded <sup>(a)</sup>.

Hydrocarbon dewpoint is a very important parameter for turbine fuel specification. Increases to the Wobbe Index typically increases the risk of forming liquid hydrocarbon droplets forming. Typical UK pipeline gas has a dewpoint of about -21°C at gas pressures of around 30 bar. This dewpoint value increases significantly with modest increases to the levels of higher hydrocarbons. For gas turbine fuel injection systems, it is important that gas-phase conditions are maintained. Any liquid fuel droplets entering the injection system can interfere both with the hardware and the heat input. Many gas turbines have fuel supply heaters to prevent dewpoint problems, hence the use of Modified Wobbe Index rather than Wobbe Index.

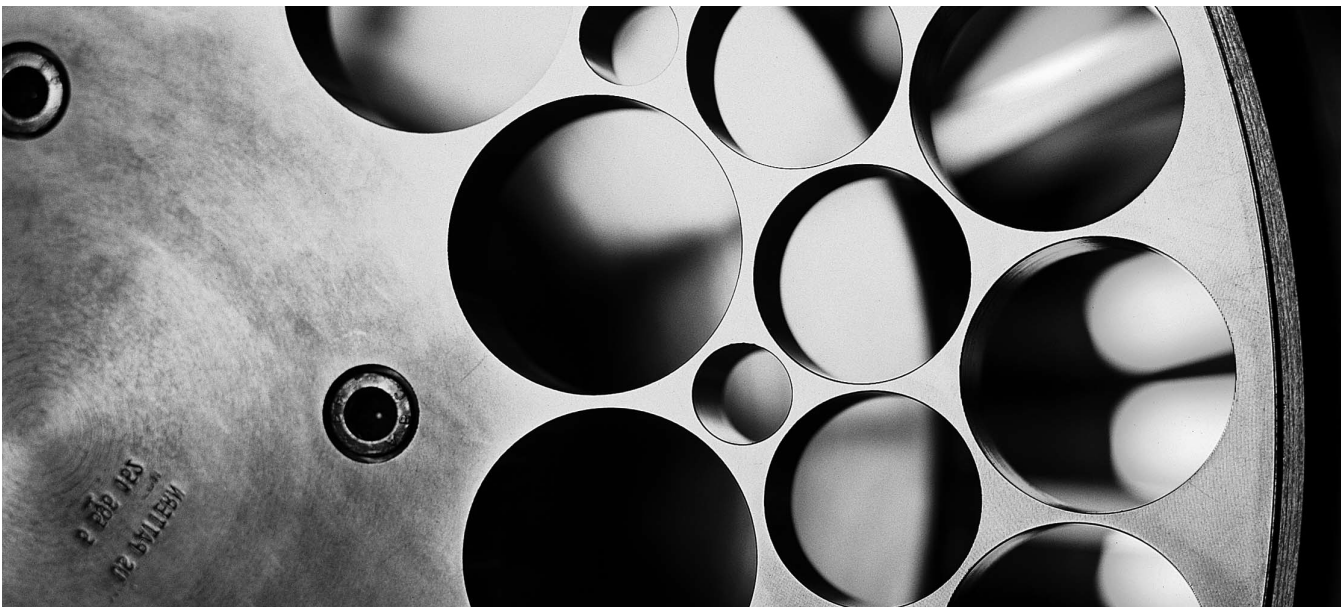
GE state that a turbine which is subject to fuel gas composition variation should have some measurement facility installed, such as a gas chromatograph <sup>(b)</sup>.

Trace components in the gas can have serious impacts on gas turbine performance. Trace metals can damage turbine blades.

Reference:

(a) GEI 41040G "Specification for Fuel Gases for Combustion in Heavy-Duty Gas Turbines" Revised issue January 2002

(b) GER 4189b "Design Considerations for Heated Gas Fuel" 2003 (see [www.gepower.com](http://www.gepower.com))





### Modified Wobbe Index

The Wobbe Index (WI) represents of the fuel energy flowing through an orifice to combustion equipment, for a contact pressure drop across the orifice

WI is a more useful indicator than calorific value alone in that it accounts for the impact of gas density on the fuel flow through a nozzle or orifice. Wobbe Index can be considered as a corrected calorific value accounting for the impact of density differences between different fuel gases on the actual heating performance.

Gas turbines typically have fuel gas heating systems to ensure that there are no problems associated with dew-point liquid drop-out. Also heating the fuel gas provides a method of control by altering the actual gas density. The fuel nozzles are designed to operate within a fixed range of pressure ratios and changes in heating value can be accommodated by increasing or decreasing the fuel nozzle area or gas temperature.

The fact that fuel gas temperature becomes an important parameter results in the use of Modified Wobbe Index (MWI). This term is used as a relative measure of the energy injected to the combustor at a fixed pressure ratio and is calculated using the fuel lower heating value, the specific gravity with respect to air and the fuel temperature. The mathematical definition is as follows:

$$\begin{aligned} MWI &= LHV / \sqrt{SG_{gas} \times T_{gas}} \\ &= LHV / \sqrt{(MW_{gas} \div 28.96) \times T_{gas}} \end{aligned}$$

where: LHV = lower heating value of the gas fuel (Btu/scf)  
 SG<sub>gas</sub> = specific gravity of the gas fuel relative to air  
 T<sub>gas</sub> = absolute temperature of the gas fuel (°Rankine)  
 MW<sub>gas</sub> = molecular weight of the gas fuel  
 28.96 = molecular weight of dry air

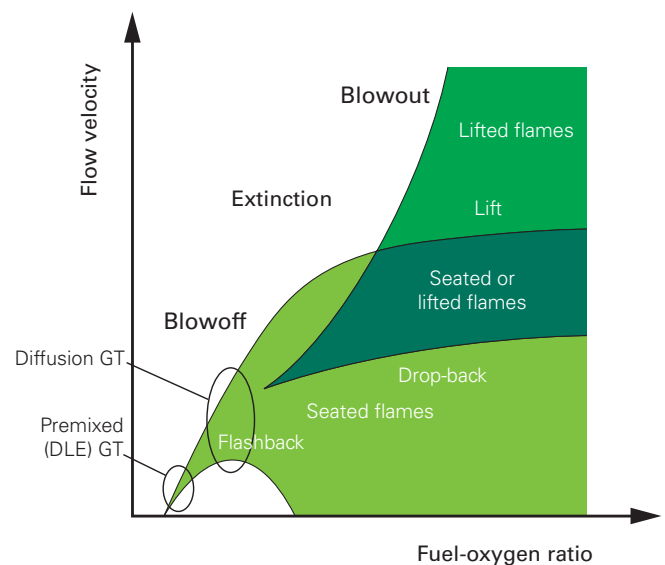
The impacts of gas composition on gas turbines have been investigated for the following factors:

- Flame failure due to change in fuel-to-oxygen ratio.
- NO<sub>x</sub> emission as a function of Wobbe Index changes.
- NO<sub>x</sub> speciation with increased higher hydrocarbon levels.
- Efficiency of catalytic combustion with variations in inert gas species and higher hydrocarbons.
- Flash-back and auto-ignition as a result of fuel gas composition variation.
- Impacts on combustion dynamics, vibration and noise.

### (a) Flame failure

Rapid changes in gas composition could result in flame failure and/or combustion induced dynamics and noise, with the further risk of vibration damage.

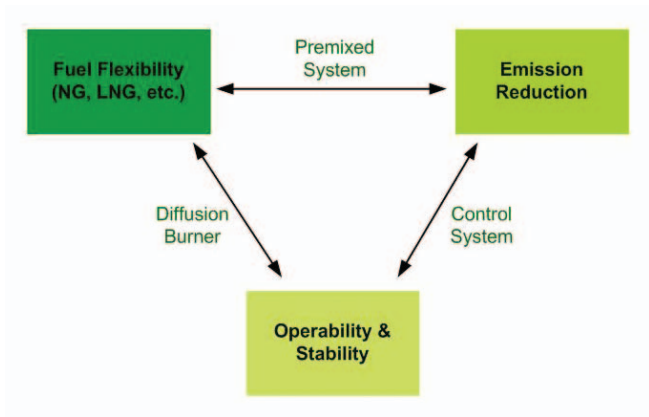
Figure 6.2 shows a traditional flame regime plot relating the overall flow and fuel-to-oxygen ratio to different flame phenomena:



**Figure 6.2** – Flame regimes as a function of fuel-oxygen ratio. Ref: White Paper on Natural Gas Interchangeability and Non-Combustion End Use NGC+ Interchangeability Work Group February 28, 2005 (from an original publication – I. Glassman “Combustion (3rd Edition)” Academic Press. 1996).

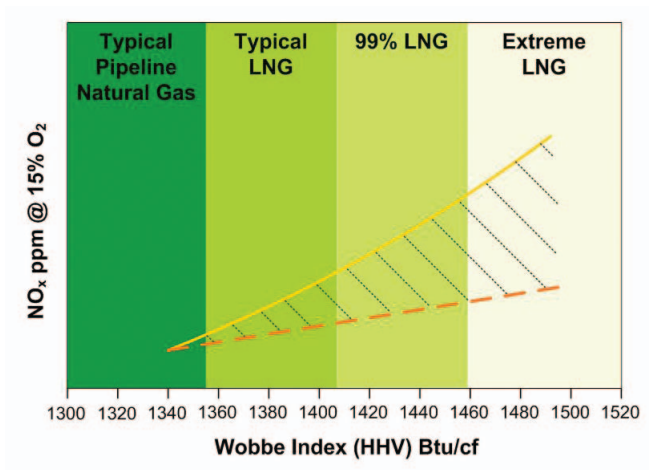
**(b) NO<sub>x</sub> Emission**

There is a trade-off between fuel flexibility, combustor type and emissions. A representation of this is shown in Figure 6.3:



**Figure 6.3** – Relationship between Fuel Flexibility, Combustor Type and Emissions.

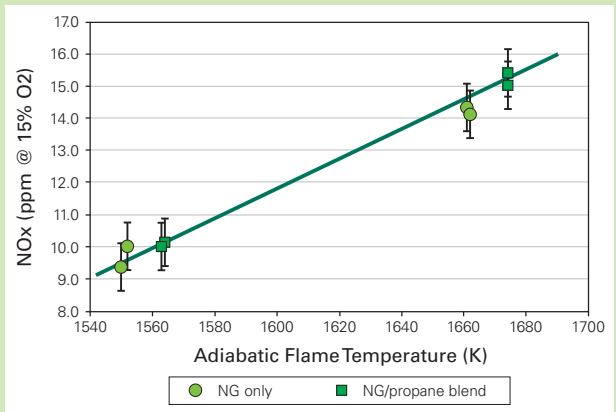
Some retuning of DLN combustors can improve emissions performance, although combustion dynamics may become more of an issue. This is demonstrated in the chart below showing NO<sub>x</sub> emission variation as a function of Wobbe Index.



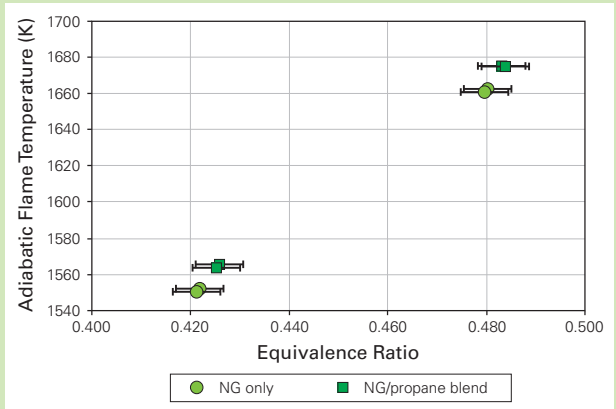
**Figure 6.4** – NO<sub>x</sub> Emissions and Wobbe Index.

**Case Study 6.3**  
**Effect of Higher Hydrocarbons on Gas Turbine Emissions**

Investigations at the National Energy Technology Laboratory in the USA have focused on a fundamental study on a simulated gas turbine system, to investigate the impact of increasing the higher hydrocarbon content of natural gas.<sup>(a,b)</sup>

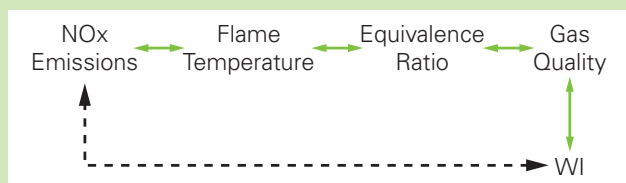


**Figure 6.5** – Impact of Flame Temperature on NO<sub>x</sub> Emission.



**Figure 6.6** – Impact of Equivalence Ratio on Flame Temperature.

This results in a correlation between different gas quality parameters as shown below:



The results from this work show that NOx emission dependence on Wobbe Index is not as pronounced as other studies and is not in line with previous data.

More research is needed but it is important to point out that these data were produced on a simulated gas turbine and the set-up is not the same as a real gas turbine. This might account for the different trends in the results.

Diluent addition can have a significant effect on the amount of fuel required to achieve constant power output from the gas turbine. In fact, diluent addition of approximately 4 - 5% can actually lead to lower flame temperatures in the combustor in order to achieve the same power output (as it is mass flow dependent). This is consistent with other observations that have shown that NOx emissions decrease with the addition of inert species in the fuel for a microturbine system.<sup>(c)</sup>

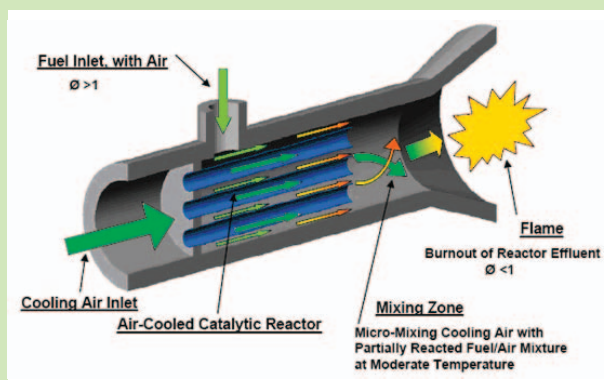
Observations made in the UK at a power plant located near an LNG import facility, have indicated that NOx does increase when regasified LNG is used.<sup>(d)</sup>

References:

- (a) 5th US Combustion Meeting organised by the Western States Section of the Combustion Institute and hosted by the University of California at San Diego March 25-28 2007.
- (b) CEC Natural Gas Interchangeability Stakeholder Advisory Committee Meeting October 29, 2007.
- (c) Hack, R. L., McDonell, V. G., "Impact of Ethane, Propane, and Diluent Content in Natural Gas on the Performance of a Commercial Microturbine Generator," ASME Paper GT2005-68777.
- (d) UK DTI Gas Quality Seminar -Issues for Generators (March 2006).

### Case Study 6.4 Catalytic Combustion Systems for Gas Turbine

Catalytic combustion in natural gas fired turbines is a technology being developed for ultra-low NOx emissions. A catalyst is used in the process to allow combustion without the significant formation of NOx and carbon monoxide (Figure 6.7).



**Figure 6.7 – Catalytic Combustor.**  
(Reproduced with permission of Combustion Inc)

Research, in the USA, has been performed using small-scale catalyst modules investigating fuel composition variation, with natural gases containing higher hydrocarbons and inert gases to simulate a range of gas quality.

Testing was done at conditions typical of a gas turbine operating at pressure ratios of 10 and 20 to cover both industrial and utility gas turbine combustor conditions. Experimental test data showed that:

- The addition of inert gases showed practically no effect on the performance.
- The addition of higher hydrocarbons led to lowering of the required catalyst inlet temperature (known as the catalyst "operating window").

From the test results, a correlation was derived for determining the window shift with quantity and carbon number of each higher hydrocarbon. The correlation was then used to calculate the operating window shifts for each of the surveyed gases. The majority of the gases, particularly in the USA, had calculated shifts of  $< 20^{\circ}\text{C}$ , which is within the tolerance of catalytic combustors. Gases with shifts greater than this can be used in catalytic combustion systems but the catalyst inlet temperature has to be lowered to maintain combustor durability.

The results of the study confirm the ability of catalytic combustion systems to run on natural gas with a wide range of fuel compositions. For most gases, the variability does not impact detrimentally on combustor durability.

Reference: "Durability of Catalytic Combustion Systems" Report P500-02-040F prepared for California Energy Commission (March 2002). Prepared by: Catalytica Energy Systems (Contract No. 500-97-033.)

**(e) NO<sub>x</sub> Speciation  
(Brown Plume in Gas Turbine Exhaust)**

Gas turbines without post combustion emission controls that burn fuels with increased higher hydrocarbon levels have a tendency to produce brown visible plumes from the stacks, associated with increased concentrations of nitrogen dioxide (NO<sub>2</sub>).

This effect often occurs during the warm-up phase or at part-load operation, when the combustion efficiency can be lower than that at base load operation. However, there are instances where even at base load operation, visible plumes due to NO<sub>2</sub> have been observed.

**Conversion of Nitric Oxide (NO) to Nitrogen Dioxide (NO<sub>2</sub>)**

To obtain a visible plume the level of NO<sub>2</sub> has to be > 50 ppm.m (i.e. concentration of NO<sub>2</sub> multiplied by the diameter of the plume – often assumed to be the stack diameter).

The mechanism of the conversion of NO to NO<sub>2</sub> involves peroxy radical species formed from the higher hydrocarbon species and the conversion can be over 50% under certain conditions. It is worth pointing out that the total NO<sub>x</sub> emission is not altered during this process only the speciation between NO and NO<sub>2</sub>.

A further consequence of the conversion of NO to NO<sub>2</sub> due to presence of higher hydrocarbons is the effect on exhaust NO<sub>x</sub> reduction methods, like selective catalytic reduction (SCR). SCR systems generally use ammonia and active catalysts to convert NO<sub>x</sub> to nitrogen. Changing levels of NO and NO<sub>2</sub> can result in increased ammonia usage and a consequence may be that ammonia is emitted in the exhaust (so called “ammonia slip”).



**(f) Gas Turbine Burner Instability  
– Flash-back and Auto-ignition**

Premixed burners employed in DLN and DLE combustors are sensitive to flash-back and auto-ignition. Both of these events can result from changes in gas composition and relate to the impact of higher hydrocarbon species and the change to the equivalence ratio.

**Flash-back** occurs when the flame velocity increases and the flow through the combustor cannot balance the change. The flame propagates back towards the injector and ultimately can result in significant damage to the fuel nozzles and air inlet distribution system. Any minor damage will impact on the system as a whole and impair the overall combustion. There is the potential for the initial effect to lead to further combustor damage if the fault is not captured early.

Flash-back can also be a result of combustion dynamics (see Section 6.3(e)). Figure 6.8 shows flash-back damage to the air swirl assembly of the gas turbine combustor.



**Figure 6.8 – Gas Turbine Damage by Flash-back.**  
(Reproduced with permission of E.ON UK)

**Auto-ignition** occurs when fuel is injected into the preheated air stream at a temperature high enough to start the combustion process without an ignition source. Higher hydrocarbon species have significantly lower auto-ignition temperatures than methane. Two different fuels with nominally the same Wobbe Index but with different levels of higher hydrocarbon species will exhibit different auto-ignition behaviours. Inert species do not have a significant effect.

Auto-ignition requires time for combustion reactions to give rise to thermal runaway and increase in rate leading to a full ignition, known as the ignition delay time. If the high temperature contact time is shorter than the ignition delay time, then auto-ignition will be prevented. This provides gas turbine design engineers with a time scale (residence time) for the premix systems.

The problem with auto-ignition is the difficulty of predicting the impact of fuel composition as there are only limited data available under gas turbine operating conditions. Auto-ignition delay times of the order of tens of milliseconds are expected for typical mixtures used in gas turbines, and residence times of the order of a few milliseconds in the combustor cans are used in many cases. Thus, although there is a safety margin, it could be reduced significantly if the gas composition changes result in lowering the auto-ignition delay.

#### (g) Gas Turbine Burner Instability – Dynamics, Vibration and Noise

Changes in gas composition can lead to combustion oscillations. These in turn can give rise to both noise and pressure pulsations leading to mechanical vibration. If the integrity of the mechanical structure of the gas turbine is compromised, it can give rise to fatigue stresses and potential failure of mechanical components. These can lead to extremely high repair and re-fit costs.

Dynamics and combustion oscillations provide a feedback mechanism to the combustion process. The result of a small oscillation is often a much larger one, with the associated increase in impact on the combustor. Resonance within the combustion chamber can give rise to excessive noise.

Figure 6.9 shows the impact of combustion dynamics and combustion oscillations (from a power station owned and operated by E.ON). There is clear damage to the fuel injectors and the combustor lining.



**Figure 6.9** – *Impact of Combustion Dynamics and Combustion Oscillations.*

(Reproduced with permission of E.ON UK)

#### Microturbines

Microturbines are small combustion turbines that produce 25 - 500 kW of power. They are typically used for small-scale on-site power generation and in combined heat and power applications.

The fuel control system can be optimised for a given fuel composition by setting parameters determined from its physical properties in the microturbine control system software. When configured for baseline natural gas most microturbines are tolerant of a 10 - 15% swing in the "fuel index". This is a parameter calculated from the gas specific gravity and gross calorific value.

The effect of variation in gas quality is summarised below:

- **Emissions** – in general NO<sub>x</sub>, CO and total hydrocarbon (THC) emissions will be adversely affected as the proportion of heavier hydrocarbons rise relative to methane.
- **Condensates** – presence of liquid droplets can cause serious damage to the engine. A Capstone microturbine for example, has a requirement to maintain the fuel gas at 10°C above its dew point at all points in the fuel system.

**Gas quality variation can affect the system integrity, engine performance and emissions profiles of gas engines. Specifications for critical components are in place to prevent damage to the engine system that are caused by corrosion and catalyst poisoning. The operations of gas engines are mainly governed by three factors: air-to-fuel ratio, gas composition (Octane Rating or Methane Number) and exhaust catalyst reactivity.**

Impacts of gas quality and interchangeability on gas engines include aspects relating to the fuel composition and in addition its burning characteristics.

Increasing use of adaptive engine control systems enables the latest generation of engines to be more tolerant of hydrocarbon composition variations. Some of the older generation of engines can incur serious damage if run on gas with a lower knock rating for any length of time.

The impacts of gas quality on the system integrity, engine performance and emissions of gas engines are governed by various standards explained below.

### System Integrity

The ISO standard 15403 (Natural Gas. Quality Designation for Use as a Compressed Fuel for Vehicles.) sets limit values for certain properties for natural gas for road transportation use. The critical issues regarding gas composition are listed below:

**Table 6.3** – Gas Specifications for Vehicle Engines.

Water content	<0.03 g/m <sup>3</sup> for the expected T and P range
Sulfur compounds	< 120 mg/m <sup>3</sup> if there is water present to prevent: <ul style="list-style-type: none"> <li>• Corrosion</li> <li>• Poisoning of exhaust catalyst</li> </ul>
Particulate matter	
Higher hydrocarbons	
Carbon dioxide	< 3%
Free oxygen	< 3%
Glycol/methanol	No glycol/methanol shall be added
Oil content	70 to 200 ppm
Corrosive components	

### Engine Performance

The performance and emissions of spark-ignition engines depend on good ignition, optimum combustion rate, adequate knock resistance and a controlled energy content of the fuel mixture.

The key performance parameters for gas engine performance are the air-to-fuel ratio, gas composition (Wobbe Index and Methane Number) and knock resistance.

#### (a) Air-to-fuel Ratio

- The main factor determining the energy content of the mixture. A change in air-to-fuel ratio has a much greater effect on power capacity than a change in gas composition.
- Engine efficiency peaks over air-to-fuel range of 1.05 - 1.10 but the NO<sub>x</sub> output is high in this range. Engine should run slightly fuel rich (air-to-fuel ratio ~0.9) to obtain the maximum torque.
- In spark ignition engines, the ignitability is strongly correlated with air-to-fuel ratio. Ignition of natural gas usually presents no problems if the air-to-fuel ratio is in the range of 0.9 - 1.5.
- Variations in air-to-fuel ratio also affects the speed of combustion. An increase in air-to-fuel ratio from stoichiometric leads to a longer time duration of the overall combustion process. This means that if engines have been timed for stoichiometric combustion, the timing should be advanced if the mixture is lean.
- The addition of inert gases such as nitrogen and carbon dioxide results in a lower combustion rate and again a need to advance spark timing. Turbocharging can be used to compensate for this effect.

#### (b) Gas Composition and Wobbe Index

- The influence of gas composition on engine behaviour can be adequately characterised by two measures: the Wobbe Index and the Methane Number.
- If the Wobbe Index remains constant, a change in the gas composition will not lead to a noticeable change in the air-to-fuel ratio and combustion rate. But this change in composition will change the volumetric energy content and knock resistance of the mixture.
- The Wobbe Index of the gas can also affect the output of an engine, resulting in loss of vehicle power if, for example, the nitrogen content of the gas increases.

### Impacts of Gas Composition on Natural Gas Vehicles

The effect of varying gas composition on vehicle performance is a concern for the natural gas vehicle (NGV) industry. NGVs which are conversions of original petrol vehicles will usually have sophisticated “closed loop” control systems which can adjust the air-to-fuel ratio to take account of varying gas composition.

With larger vehicles, such as trucks and buses, which are based on conversions of high-compression diesel engines, the effect of gas composition is more critical. These vehicles typically operate at maximum efficiency, close to the “knock limit” of the fuel. Changes to gas composition (e.g. increasing higher hydrocarbon content) can alter the potential for “pinking”, indicating incorrect ignition of the fuel in the engine cylinder. This can result in engine damage in the long term.

### (c) Knock Resistance

- A high thermal efficiency requires a high compression ratio, and hence a fuel with a high knock resistance. Natural gas has a higher knock resistance than petrol. Engines designed with a high compression ratio to match this high knock resistance will show a significant increase in efficiency.
- Knock rating of fuel decreases with presence of heavy hydrocarbons. This can lead to serious engine damage where engines are unprotected.

### Emissions

The exhaust emissions of most concern from natural gas fuelled vehicles are NO<sub>x</sub>, carbon monoxide, and unburnt hydrocarbons. It is recognised that carbon dioxide is the major emission and can be classified as a pollutant but the carbon dioxide emission based on a unit of energy input, is lower for natural gas fuelled vehicles than for those using petrol, diesel or liquefied petroleum gas (LPG).

- The production of NO<sub>x</sub> is determined by the peak temperature in the combustion process and the availability of oxygen. Thus, if the gas composition changes, the formation of NO<sub>x</sub> is affected as the peak temperature and air-to-fuel ratio changes.
- Carbon monoxide is produced in significant quantities when there is insufficient air to complete the combustion process (represented as an air-to-fuel ratio of less than 1.0). Also, carbon monoxide can be formed if the flame is quenched by a cool surface.
- Unburnt hydrocarbons from incomplete combustion of the fuel tend to increase with leaner mixture because of lower temperatures and flame speeds. Differences in the concentration of higher hydrocarbons in the fuel can affect the species composition and reactivity of the exhaust catalyst, leading to higher total hydrocarbons (THC) discharge values.

- This is especially important in countries that legislate on emissions of non-methane hydrocarbons (NMHC), as the level of higher hydrocarbon species in the fuel directly affects the levels of non-methane hydrocarbons emissions in the exhaust. Variations in gaseous fuel composition can affect the level of pollutant emissions. The primary effect is due to variations in the Wobbe Index. With a reasonably sophisticated engine control system (hardware and software), modest variations in Wobbe Index can be accommodated and have little effect on emissions. This assumes that the engine is operating close to stoichiometric with a three-way catalyst in the exhaust and closed-loop feedback control by means of an oxygen sensor in the exhaust.

### Case Study 6.5

#### Impacts of Propane-air Addition in North America

In some areas in North America propane-air mixtures are added to the distribution system to meet peak system demands. In this situation the variation of higher hydrocarbons in compressed natural gas (CNG) will be very high. Where these gases condense out in the service station gas storage there can be further concentration as the storage pressure drops when refuelling. In this case it is almost impossible to maintain adequate control over gas quality.

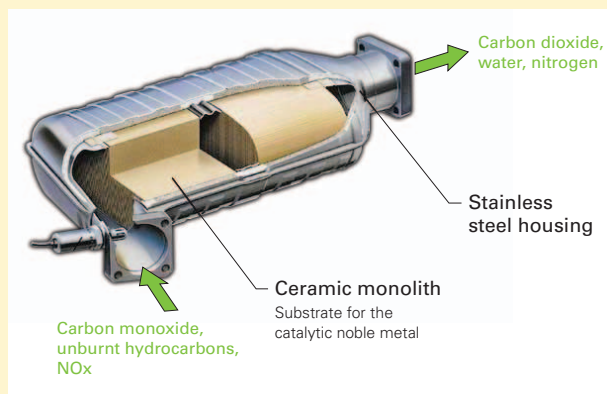
The main problem arises when the vehicle cylinder is charged with compressed gas containing high levels of propane. At low temperatures and tank pressures over 55 bar, the propane will “drop-out” of the gas phase and form a liquid and this liquid will not be withdrawn when the engine is operating. As the gaseous fuel continues to be used, the pressure will fall and the propane will become gaseous once more but the level of propane in the gaseous mixture will then be significantly higher than in the original gas fuel. This leads to significant engine control and reliability issues.

The issue is addressed in document SAE J1616 with limits set for the hydrocarbon gases other than methane. One solution suggested is to use stored liquefied natural gas (LNG) for peak shaving rather than add propane-air.

Reference: “Evaluation of Compressed Natural Gas (CNG) Fueling Systems.” Report P500-99-019 prepared for California Energy Commission (October 1999). Prepared by: ARCADIS Geraghty & Miller (Contract No. 500-98-002).

### Impact on exhaust catalyst operation

Catalytic converters are located between vehicle engines and exhausts. They are ceramic honey-comb structures coated with catalysts usually platinum, rhodium and/or palladium. Their honeycomb structure is designed to have a very high surface area to volume ratio since reactions with the catalysts only take place on the surface.



**Figure 6.10** – Honeycomb Structure of Catalytic Converter.

(Reproduced according to terms of Eberspächer website - [www.eberspaecher.com](http://www.eberspaecher.com))

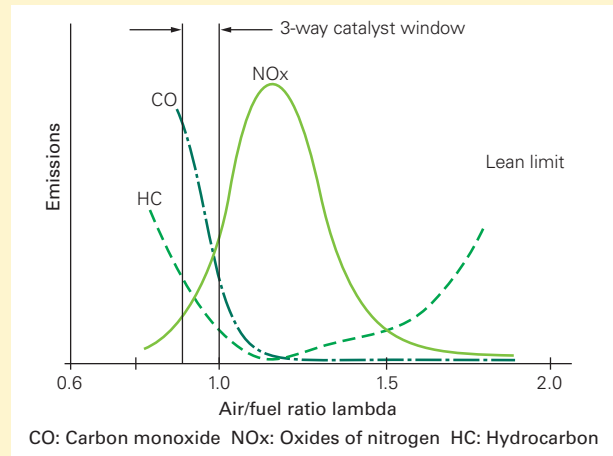
Petrol engines (spark ignition) have “3-way catalysts”, so called because they reduce emissions of three pollutants, namely carbon monoxide, unburnt hydrocarbons and NOx. A 3-way catalyst consists of two distinct sections:

- A reduction catalyst that converts NO into nitrogen and oxygen (essentially promoting the chemical reaction  $2NO \Rightarrow N_2 + O_2$ ).
- An oxidation catalyst then oxidises harmful carbon monoxide and unburnt hydrocarbon species into carbon dioxide and water.

Reduction catalysts can only operate if an engine is running close to ‘stoichiometric’. To ensure a petrol engine runs stoichiometric, an oxygen sensor is located immediately downstream (away from the engine) of the catalyst. This sensor feeds in to the electronic control unit which then regulates the amount of fuel injected in to the cylinders.

Diesel engines are designed to run ‘lean’, which means they run with more air than the stoichiometric ratio. Reduction catalysts cannot operate in lean conditions so diesel engines only have oxidation catalysts. Oxidation catalysts are effective at reducing carbon monoxide and unburnt hydrocarbons and also reduce some of the particulate matter (PM) but do not reduce NOx. This is why diesel vehicles typically have higher NOx emissions than petrol engine vehicles.

The operating “window” of the 3-way catalyst is shown below:



**Figure 6.11** – Operating Window of 3-way Catalyst

(Source: IANGV Position Paper 1997, reproduced with permission of IANGV).

If a catalyst and oxygen sensor are not used, the NOx and carbon monoxide emissions will be strongly affected if changes in fuel composition induce changes in air-to-fuel ratio.

The catalysts used may need to be modified with change in the natural gas fuel composition. Catalysts are more effective for higher hydrocarbons than for methane and ethane. Methane requires a high loading with catalyst material, a high exhaust temperature and a low space velocity. Palladium catalysts are preferred for the conversion of methane.



**The impact of gas quality on glass processing and metal reheating are related to factors such as the furnace atmosphere, flame length, flame impingement temperature and air-to-fuel ratio. This can affect the final product quality.**

**For the metal reheating industry, a low level of oxygen hardens the scale and promotes scale formation on the metal. For glass manufacturing, changes in oxygen concentration may not only affect the colour quality but can also lead to imperfection and breakage of glass fibres. This can be overcome by incorporating an on-site chromatography and air-injection unit to the process control system.**

For **metal reheating** the level of oxygen in the combustion products influences the scale formed. If the oxygen level is too low then the scale becomes hard and will not be easily removed in the forging process, whereas if the oxygen level is too high then the scale depth is too great and metal loss becomes an issue.

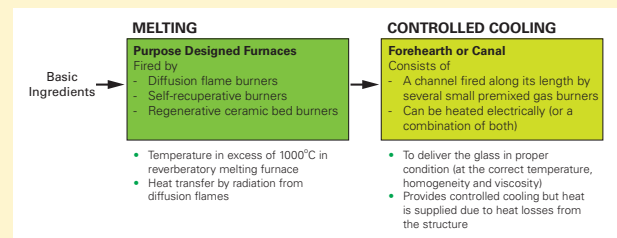
For the **glass industry** there are several problems related to gas quality. Production of coloured glass is dependent on the furnace atmosphere. If oxygen levels within the furnace change, or if the flame temperature alters then colour quality can diminish. Cutting and finishing of toughened safety glass requires burner operation near to the stoichiometric value. Thus any change to Wobbe Index will impact on both flame temperature and emissions.

### Glass Industry and Manufacturing Process

The glass industry is divided into the following sectors based on end products:

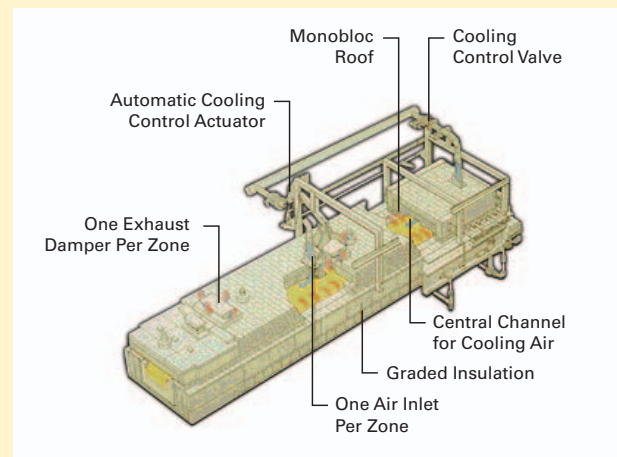
- Flat glass – Windows, picture glass.
- Container glass – Bottles, jars, and packaging.
- Pressed/blown glass – Table and ovenware, flat panel display glass, light bulbs, television tubes, scientific and medical glassware.
- Glass fibre – Insulation (fibreglass), textile fibres for material reinforcement, and optical fibres.

The basic process of glass manufacture is described in Figure 6.12:



**Figure 6.12 – Basic Process of Glass Manufacturing.**

A general layout of a forehearth is shown in Figure 6.13. It is typically completely enclosed by refractory except for flue passageways.



**Figure 6.13 – General Layout of a “BH-F” Technology Forehearth (Reproduced with permission of Fives Stein Limited).**

The performance of burners, large and small, and subsequently the process can be affected by the fuel gas composition.

One solution is to ensure adequate rapid measurement of fuel gas quality and to respond to changes by adjustment of air-to-fuel ratio to the combustion system.

## Manufacturing of Glass Fibre

Continuous glass fibre is a continuous strand, made up of a large number of individual filaments of glass. Molten glass is fed from the furnace through a forehearth to a series of bushings which contain over 1,600 accurately dimensioned holes or "forming tips" in its base.

The temperature of the glass in the bushings is controlled to very fine limits. Fine filaments of glass are drawn mechanically downwards from the bushing tips at high speed, giving a very fine filament diameter (~9 microns). From the bushing the filaments run to a common collecting point where size is applied and they are subsequently brought together as bundles, or "strands", on a high-speed winder.

Glass fibre is produced in a range of filament diameters and strand dimensions to tight tolerances for different end uses. It is used to strengthen and stiffen thermosetting plastics, thermoplastics, nylon and polypropylene as well as inorganic matrices, such as gypsum.

Glass wool is made in the Crown process. From the forehearth of the "tank" a thick stream of glass flows by gravity from the bushing into a rapidly rotating alloy steel dish "Crown" which has several hundred fine holes round its periphery.

The molten glass is thrown out through the holes by centrifugal force to form filaments, which are further extended into fine fibres by a high velocity blast of hot gas. After being sprayed with a suitable bonding agent, the fibres are drawn by suction onto a horizontally moving conveyor positioned below the rotating dish.



**Figure 6.14** – *Glass Wool Manufacturing.*

The mat of tangled fibres formed on the conveyor is carried through an oven which cures the bonding agent, then to trimmers and guillotines which cut the product to size. The mat may be further processed into rigid sections for pipe insulation. The mats are made into many products for heat and sound insulation in buildings, transport vehicles and domestic appliances.

## Case Study 6.6 Impacts of Gas Composition on Glass Fibre Manufacturing

Glass-fibre manufacture is sensitive to changes in gas quality. Problems have been experienced in a factory in the UK that could receive gas from several off-takes in the transmission network. The gas received by the factory depended on the load demands on the network and as such, its quality was not predictable.

The glass making process was critically dependent on a series of pre-mixed burners in the forehearth. These burners had to maintain a constant oxygen partial pressure within the furnace and tight temperature control. Variations in gas quality resulted in changes in the oxygen concentration above the glass melt leading to:

- Imperfections in the glass.
- A reduction of product quality and consequently breakage of glass fibres lead to loss of production.

To rectify the problem, in the first instance, manual intervention was required to change the burner controls to re-establish optimum combustion performance. The air-to-fuel ratio was set but it was impractical to make changes in a short time when gas quality changed. During this time, the product quality reduced and there was a corresponding loss in production.

From a practical viewpoint, manual intervention is not a long-term solution and to overcome the effects of changes in gas quality. Following the installation of an automatic gas chromatograph close to site, evidence suggested that problems were associated with step changes in concentrations of nitrogen and hydrogen sulphide in the gas supply, although the physical properties were still within the statutory limits.

It was decided that the air-injection-control system would have to be an integral part of the process control, and the problem was resolved by including a Wobbe Index control system in the gas supply to the plant, using air injection as the ballasting control mechanism.

Reference: Advantica confidential report

### Case Study 6.7 Impacts of Gas Composition on Television Tube Manufacturing

Maintaining a constant glass furnace temperature is a very important factor for manufacturing television tubes. Relatively small changes to the glass furnace temperature can cause product flaws and increase product rejection rates. Some manufacturers have experienced rejection rates up to 60% when the process temperature fluctuates.

With the process requirement of accurate temperature control, it is clearly evident that changes to the composition of the fuel gas have the potential to adversely impact on the manufacturing process.

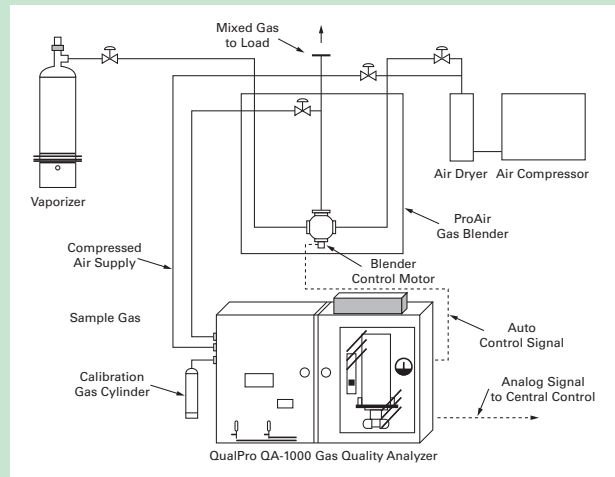
This problem has been recognised for several years and the ProAir Natural Gas Stabilization System has been developed and installed in several television tube manufacturing sites around the world.

The overall process uses a variable air ballast or dilution to maintain a constant calorific value, and it relies on highly accurate gas quality measurements and flow control. The process is set up with the minimum Calorific Value of the expected range of gas composition. The gas quality analyser measures the burning characteristics of the fuel gas and then adjusts the flowmeter blender to alter the amount of air ballast. The amount of air added to the fuel gas is typically in the range 1 to 10%.

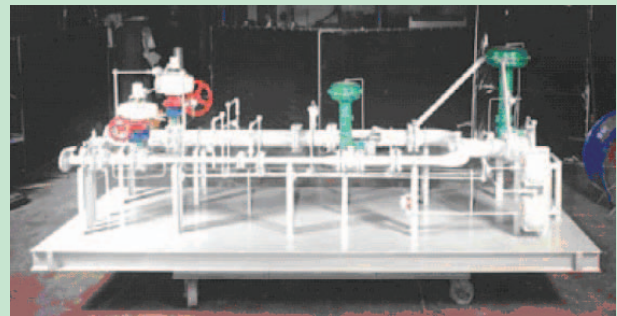
A schematic diagram of the control system is shown in Figure 6.15.

The claims from the manufacturer are that for changes in Calorific Value of the natural gas of up to 15%, the control system can give resultant variation of about 1% in the heat content.

A photograph of a skid mounted mixing valve assembly is shown in Figure 6.16.



**Figure 6.15:** Schematic of ProAir Control System  
(Reproduced with permission of Superior Energy Systems Ltd)



**Figure 6.16 – ProAir Natural Gas Stabilization System.**  
(Reproduced with permission of Superior Energy Systems Ltd)

Reference: Energy Solutions Centre. (see [energysolutionscenter.org](http://energysolutionscenter.org))

## 6.6 Chemicals – Methane Steam Reforming

---

**An increase in the higher hydrocarbon content in the natural gas feedstock to a methane steam reforming process could lead to catalyst deactivation (by carbon deposition) and implications for plant operating conditions (by the high CO<sub>2</sub>-to-H<sub>2</sub> ratio). A pre-reforming process would help in removing any undesired impurities and offers flexibility in feedstock.**

---

Natural gas is used in the chemical industry as both fuel and feedstock. The steam reforming process is used for the production of hydrogen from hydrocarbons. Hydrogen has many industrial applications and a major proportion is used to manufacture ammonia which serves as base feed to manufacture nitrate, phosphate and urea based fertilisers for agriculture.

Hydrogen plant operators will have to accommodate natural gas feedstock containing hydrocarbons heavier than methane. There are two significant effects to consider with increase in higher hydrocarbon content (increased Wobbe Index):

- Increased tendency to form carbon deposits which deactivate the catalyst used for the reforming reaction. This may cause unscheduled shutdowns to replace the reforming catalyst.
- Higher carbon dioxide to hydrogen ratio. This has implications for plant operating conditions, shift reaction catalyst life and product purification duty.

The inclusion of a pre-reformer upstream of the primary reformer offers flexibility in feedstock with added benefit of energy savings.

One of the steps in the reforming process is desulphurisation where hydrogen sulphide is removed to prevent poisoning of the reforming catalyst. The most common method to achieve this is to use an activated carbon bed. Heavier hydrocarbons are known to decrease the effectiveness of the carbon and higher sulphur content will lead to more frequent regeneration of carbon. This is achieved by passing superheated steam through the bed and will impact on the energy balance of the plant.







## Chapter 7

### Options to Manage Gas and LNG Interchangeability

The earlier chapters have set out to illustrate the wide range of gas quality and interchangeability impacts, from upstream gas production, through transportation and networks, to the point of combustion. Everyone in the gas industry is likely to be affected in some way in their day to day activities by the effects of gas quality.

Declining indigenous gas reserves, general moves towards shorter term contracts and increasing trade of liquefied natural gas (LNG) 'spot' cargoes have increased the risk of exposure to various different gas quality specifications. This makes LNG quality adjustment increasingly important.

This chapter will cover how these effects can be managed to ensure that gas which always meets the accepted specifications is supplied to consumers, thus ensuring safe use.

There is a wide range of available options to deal with gas quality variations, applied at points from upstream extraction through to end-use. This ensures gas can safely reach the markets even when it starts its journey with a composition which is far from what customers need. The choice of methods used requires a strategic approach which takes into account the whole of the "gas chain" as well as commercial, trading and regulatory aspects.

## 7.1 Options for Gas Quality Management

- Where should it be done? Options for gas quality management at production, upstream, midstream and downstream are listed alongside the appropriate techniques for each application.

## 7.2 Blending

- Co-mingling of an off-specification gas/LNG with another in- or off-specification stream could be the most cost effective way to bring the combined stream within range. Three blending techniques are discussed here: in LNG tanks, in the send-out section and in the transmission network.

## 7.3 Derichment

- Derichment options lower the Wobbe Index and Heating Value of rich natural gas. The two ways to achieve this are injecting an inert gas (ballasting) into the gas or removing rich components from it.

### 7.3.1 Ballasting

- Nitrogen, carbon dioxide, air and hydrogen are the choices for ballasting. They are discussed and compared in this section. Issues associated with each technique are also highlighted.

### 7.3.2 Liquefied Petroleum Gas (LPG) or Natural Gas Liquid (NGL) Removal

- Removal of the higher hydrocarbons in natural gas or LNG helps to reduce the Wobbe Index and provides opportunities for reforming the hydrocarbons back to natural gas. Although this is not currently implemented at any LNG plant, it has been and can be. It is explained here and compared with other methods.

## 7.4 Enrichment

- An enrichment process increases the Wobbe Index or Heating Value of lean natural gas by injecting higher hydrocarbons (typically LPG) or by removal of inert gas (nitrogen or carbon dioxide).

### 7.4.1 LPG Injection

- Propane, butane or a mixture of both is typically injected into natural gas to increase the Wobbe Index. This, however, also results in an increased hydrocarbon condensation temperature (dewpoint). The pros and cons of LPG injection are discussed here.

### 7.4.2 Inert or Carbon Dioxide Removal

- This section discusses various technologies established for the removal of carbon dioxide or nitrogen from natural gas and also technology for the removal of nitrogen from LNG.

## 7.5 Control of Send-Out Gas Quality for LNG

- Quality control prior to send-out point is crucial to meet the network entry specifications. A description of the quality control system is provided here, followed by case studies for quality adjustment programmes in Japan and USA.

## 7.6 Quality Correction Downstream of the Network

- Combustion control at the point of use involves measurement of gas properties, exhaust oxygen monitoring, adaptive engine tuning and blending.

## 7.1 Options for Gas Quality Management

**Quality adjustment of gas or liquefied natural gas (LNG) can be carried out at various stages in the chain of natural gas production and use, to meet contractual specifications.**

**Techniques listed below are widely used for quality adjustment at point of production, as well as at import terminal prior to send-out point, with the exception of blending which is mainly carried out in the transmission network:**

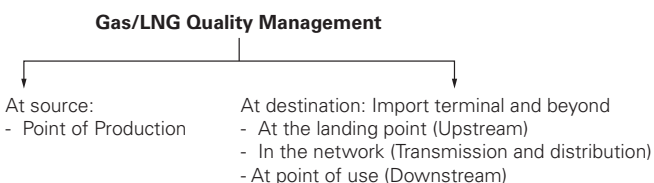
- **Ballasting with inert gas.**
- **Propane/butane removal/injection.**
- **Carbon dioxide or nitrogen removal.**
- **Blending of different streams.**

**Control of combustion process (air-to-fuel ratio) is often preferred at the point of use to cope with the variation in gas quality.**

The major gas quality concerns with pipeline natural gas and liquefied natural gas (LNG) are gas interchangeability (measured by parameters such as Wobbe Index and/or Heating Value) and their operational impacts on gas transportation. Excess concentration of components such as carbon dioxide, hydrogen sulphide and water have adverse impacts on the operation of transmission/ distribution networks, causing blockages and corrosion. The impurity removal processes were discussed in detail in Chapter 4. This chapter focuses on issues related to gas quality adjustment methods to ensure interchangeability.

The options for gas interchangeability adjustment can be deployed at various stages, depending on the contractual terms:

- Producers/exporters treat their gases to meet the specifications in sales agreements, or to the market demands.
- Beyond the sourced gas/LNG landing point, it is the responsibility of either importers or network operators to ensure the gas supplied meets local specifications.



**Figure 7.1** – *Quality Management at Different Points.*

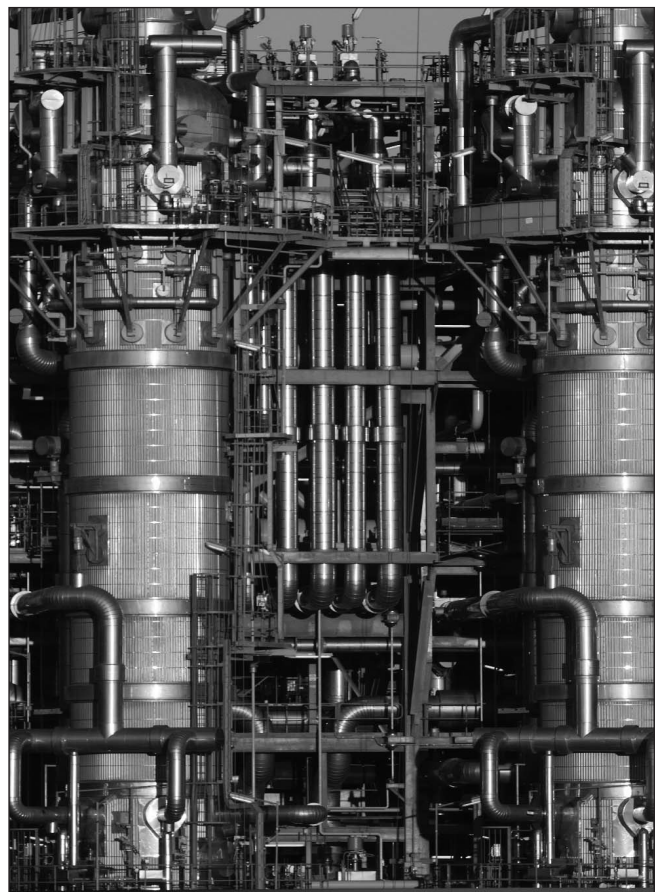
Compared to pipeline natural gas, LNG generally has low nitrogen content and very low (if not negligible) carbon dioxide, hydrogen sulphide and water contents. In cryogenic liquid form also poses a different set of criteria for quality adjustment, which can be carried out at both LNG import terminals and LNG liquefaction plants.

### LNG Quality Management at Import Terminal

Adjusting LNG quality at an import terminal is advantageous compared to liquefaction plant, for the following reasons:

- It minimises the processing requirements at the liquefaction plant, therefore reducing capital expenditure and cost of producing the LNG.
- Shipping relatively rich LNG leads to a lower shipping cost per unit of energy than shipping relatively lean LNG.

However, these savings would be at the cost of increased capital and operating expenditure at the LNG import terminal(s), if the quality of the LNG supplied is outside of the local specification. A detailed technical and economic evaluation would be required to determine the best course of action depending on a variety of factors, such as the technical feasibility, cost, contractual terms and ownership structures.





There is some overlap between quality management techniques that can be applied to natural gas (including regasified LNG) and LNG (in its cryogenic liquid form), as summarised in Table 7.1. While the quality of sourced pipeline gas could lie at either end of the heat value range, LNG typically has a richer composition and needs derichment to reduce its heating value.

**Table 7.1** – Options for Gas/LNG Quality Adjustments.

Gas Quality Management Technique	D/E <sup>1</sup>
<b>At gas/LNG production</b> <ul style="list-style-type: none"> <li>LPG and/or ethane extraction</li> <li>Nitrogen injection</li> <li>LPG injection</li> </ul>	D D E
<b>At import terminal</b> <ul style="list-style-type: none"> <li>Ballasting with inert gas</li> <li>Fractionation (LPG and/or ethane removal)</li> <li>LPG Injection</li> <li>Inert or CO<sub>2</sub> removal</li> <li>Blending of different streams</li> </ul>	D D E E D/E
<b>In the network</b> <ul style="list-style-type: none"> <li>Gases of different compositions</li> </ul>	D/E
<b>At point of use</b> <ul style="list-style-type: none"> <li>Ballasting with inert gas</li> <li>LPG injection</li> <li>Blending</li> <li>Downstream process control <sup>2</sup></li> </ul>	D E D/E –

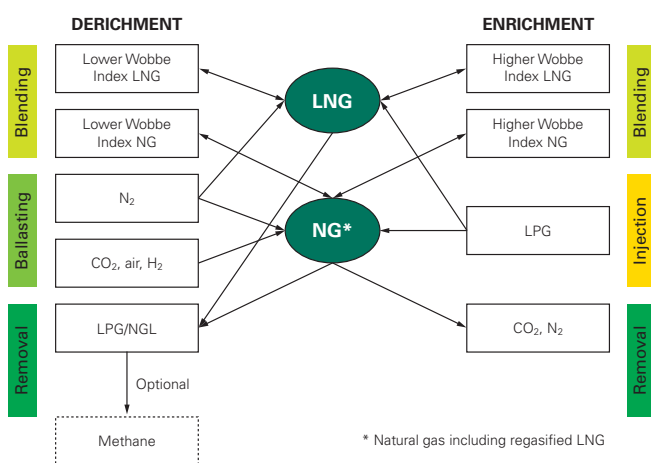
<sup>1</sup> Derichment (D) or enrichment (E) process

<sup>2</sup> Combustion process control to ensure a correct air-to-fuel ratio

### At the Point of Production

Quality correction at the point of production is managed by the producer or export terminal operator according to the export requirements. This can either increase or decrease the heating value of the gas or transported LNG to contractual specifications. Similar derichment and enrichment techniques to those shown in Figure 7.2 can be applied:

- Nitrogen can be added to LNG to reduce its Wobbe Index, but the shipping and receiving end requirements would need to be checked. Generally there is a 1% nitrogen limit for LNG shipping to reduce the risk of rollover problems – see Chapter 4 for more details.
- Derichment by removing liquefied petroleum gas (LPG, mainly propane and butane) and ethane is dependent on the degree of extraction required and a market for its disposal. The resale value of ethane does not usually support the cost of extraction.
- Injecting LPG requires a local source of LPG and the installation of facilities for LNG unloading and storage. It is unlikely to be economically feasible unless there are land restrictions at the receiving end. However, if the liquefaction facility ships LNG to several different markets, it is possible that a plant with significant LPG in the feed could be considered for both low and high heating value markets. In this case, the LPG could be extracted and stored until a high heating value cargo is required.



**Figure 7.2** – Summary of Quality Management Techniques for LNG and Natural Gas.

### **For the Network (Upstream, Transmission and Distribution)**

Similar derichment and enrichment techniques to those used at the point of production can also be used for gas/LNG quality adjustment at destination, i.e. import terminal and beyond. This, however, is subject to a different set of criteria, mainly to meet the contractual network entry requirements.

Depending on the local network entry requirements and composition of the sourced gas or supplied LNG, quality correction will either be enrichment (increasing heating value) or derichment (decreasing heating value).

Blending, of course, wherever it occurs can be classed as enrichment or derichment depending on the reference gas stream.

Techniques involving LNG are applied up to the send-out points at LNG import terminals, as it is then regasified prior to entering the transmission network.

These techniques are discussed further in Section 7.2, Section 7.3 and Section 7.4, along with their likely feasibilities, and compared and contrasted where appropriate.

### **At the Point of Use**

Downstream process controls which allow combustion of variable quality gases are discussed in Section 7.6.

#### **Case Study 7.1 Gas Quality Management in UK Interconnector**

In 2003 the UK's gas quality specification was first raised as a potential constraint for shippers importing gas from Continental Europe. Since then it has been reviewed at various times, first through the DTI's Three Phase Study and subsequently by Ofgem. The Government as part of the Three Phase Study ruled out the possibility of changing gas appliances in the UK, leaving the installation of a nitrogen ballasting plant as the only long term option available to the UK. In 2006, discussions broke down between Ofgem and the shipping community after Ofgem considered that interconnector shippers should fully underwrite investment in a ballasting plant, even though the actual need for this facility had not been fully explored.

More recently Fluxys (The Belgian TSO) has suggested that its ability to manage the quality of gas at Zeebrugge is becoming challenging due to unpredictable flows through the VtN pipeline from Eynatten and higher Wobbe gas flowing from Norway through Zeepipe. This has been

supported by reports that there have been a handful of incidents during 2010 and 2011 when the Wobbe has spiked above the UK GS(M)R specification. Up until now these spikes have only lasted a few hours and IUK has not been flowing gas in the direction towards the UK (reverse flow) so shippers' nominations have not been curtailed.

However, some are of the view that this problem will progressively worsen once Nordstream is commissioned given that initial tests on the wells providing gas for Nordstream are showing much richer gas than previously expected. Currently there is insufficient evidence and analysis to back up these claims but if it is proven that gas quality is and will continue to impede the trade and flow of gas to the UK then there is a potential risk that on specific days interconnector flows could be curtailed affecting shippers' ability to send gas to the UK.

Fluxys have since proposed that they are prepared to consider providing a service using existing system capabilities, with some cost recovery on a "polluter pays" basis.

**Upstream – Transmission**

Blending is typically a low cost option and can be used for both derichment and enrichment depending on the quality of the blending gas available.

At an LNG export/import terminal, blending of LNG between tanks in its cryogenic liquid form can be done for quality management. This is a routine operation for many import terminals receiving LNG from diverse suppliers and where storage is limited. It requires careful tank capacity management and monitoring to avoid stratification (explained in Chapter 4).

Another upstream adjustment option is blending of LNG in the send out section prior to entering transmission pipeline, to eliminate the need for an extra blending tank.

Blending in the network deals with transient changes of gas quality and is not always possible. It is very situation specific depending on pipeline sizes, gas specifications and customer offtakes.

Three blending techniques are discussed here:

- Blending in LNG tanks (for LNG only).
- Blending in the send-out section of an LNG import terminal (for LNG only).
- Blending in the transmission network.

For LNG, in-tank blending is likely to be the cheapest option provided no additional storage tank is required and stratification problems can be avoided.

**Blending in LNG Tanks**

This often takes place to free-up capacity for the next cargo to be unloaded, generally as an operational side effect rather than an operational objective.

**Issue with LNG In-tank Blending**

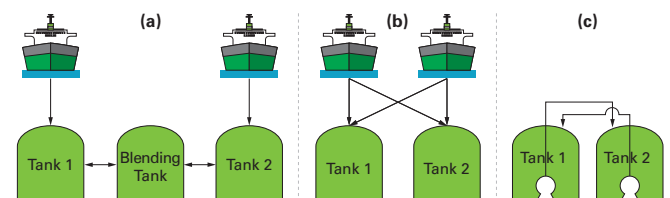
- LNG that is mixed in tanks is usually of a similar density; however, where the LNG densities are significantly different, then stratification and roll-over may become a concern (see Chapter 4).

In order to avoid this, a terminal operator should ensure that appropriate measures are taken to avoid excessive stratification leading to a rollover. For example, using a level-temperature-density (LTD) gauge to manage the density profile in the tank.

- Top filling encourages boil-off gas (BOG) generation so bottom filling is normally preferred. BOG is generated by mixing so in-tank mixing should be done slowly to avoid overloading BOG systems.

If in-tank blending of LNG for quality correction was used, then three approaches can be envisaged:

- A tank is designated for each LNG source and a further tank is used for blending LNG.
- All LNG cargos are proportionately distributed between the available tanks and Heating Values and tank levels remain the same in each tank.
- Pumping between tanks.



**Figure 7.4 – LNG Tank Blending Techniques.**

The first approach has significant operational advantages in providing sufficient storage to be able to segregate each delivery according to source, and to blend in a separate tank. However, it requires at least three tanks which, particularly for low throughput terminals, would represent a significant cost. Furthermore, it is unlikely that all tanks would be fully utilized as it is possible to foresee a situation whereby a ship arrived out of sequence and was unable to discharge all of its cargo because the tank designated for that LNG source was full, whilst tanks designated for other LNG sources had spare capacity.

LNG quality can be adjusted as it is unloaded by varying tank pressures to reduce or increase BOG rates. This preferentially removes nitrogen (and methane) potentially making the LNG heavier. The BOG may need Calorific Value modification (enrichment) to be within send-out specifications but it may be possible to blend in the recondenser.

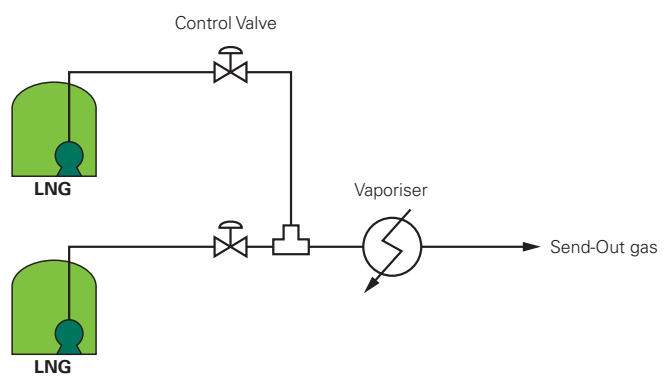
The second approach has the advantage of not necessarily requiring an additional tank; the number of tanks required is dependent upon other considerations such as total send-out rate and cargo delivery schedule. Therefore, there is a considerable incentive to blend directly in-tank from the ship, by discharging a proportionate amount of the cargo to each tank. In order to correct any failure to maintain the same Heating Value and level in each of the tanks, it would be prudent to have the ability to pump LNG between tanks.

A good flexible configuration for a large terminal could be three tanks each containing three pumps capable of delivering 33% of the send-out rate. This configuration would allow one pump per tank to be on send-out duty (i.e. maintaining the same level in each tank) whilst one or both of the other two pumps in each tank could be used to circulate LNG from the bottom to the top of the tank (i.e. to provide additional mixing) or to transfer LNG between tanks. A flexible configuration for a smaller terminal could be to have two tanks that each contained three pumps capable of delivering 50% of the send-out rate. The advantage of a three pump per tank arrangement is that it allows for continued operation on failure of one pump in each tank, although it would take longer to complete in-tank circulation mixing operations.

In order to consistently produce a particular Heating Value specification using either approach it would be necessary to carefully schedule deliveries and volumes of the two or more LNG types to be blended. Also, good control over tank inventory and filling operations would be essential, and a continuous analysis of the composition of the LNG in storage would be necessary to ensure that appropriate cargoes are scheduled in good time. Another issue that would need to be considered is that heat from the circulation pumps would generate additional boil-off gas.

### Blending in the Send-Out Section of an LNG Import Terminal

An alternative approach to blending in LNG tanks is to blend in the send-out section of a LNG import terminal. This could be achieved by blending LNG downstream of two or more LNG tanks, but upstream of the LNG vaporisers. In order to achieve the desired send-out gas quality, it would be necessary to control the flow rate of LNG from each tank such that each LNG was added in the correct proportion.



**Figure 7.5** – *Blending of LNG in the Send-Out Section*

An advantage of this technique compared to blending in LNG tanks is that no blending tank is required.

Disadvantages of this technique are:

- It is necessary to have separate tanks for each LNG source, which is likely to increase the total storage capacity and capital cost of the terminal.
- This type of blending may require special control strategies.
- It is unlikely that these tanks would be fully utilised as it is possible to foresee a situation whereby a ship would be unable to discharge all of its cargo because the tank designated for that LNG source was full, whilst tanks designated for other LNG sources had spare capacity.

However, provided careful control is kept of inventories and compositions, blending in the send-out section can be combined with in-tank blending to use the LNG storage capacity efficiently.

### Blending In the Network

An alternative to blending in the import terminal is to blend further downstream at the entry into a pipeline network. The feasibility of this technique is very situation specific and is dependent on factors such as:

- The operations of other shippers;
- The size of the pipeline network;
- Quality specifications of the gas streams, and
- Safety regulator approval.

In particular, the flow rate of gas available for blending with re-gasified LNG from an import terminal would have to be high enough to ensure that the blended gas stayed within the specified quality range of the pipeline network.

Unfortunately, given that the gas send-out rate from an LNG import terminal is usually substantial when compared to the flow rate in the network that it enters, there are currently very few places in the world where this can be achieved other than the Gulf Coast of the USA and possibly at Zeebrugge in Belgium. However, other opportunities will arise as the number of LNG sources and supply points increase.

One potential network entry point that could be particularly advantageous is upstream of an existing NGL recovery plant such as those that exist in the USA. This would enable the Heating Value of a rich LNG to be reduced such that it met the downstream pipeline quality specification. However, this will still cause issues:

- The send-out rate from the import terminal would probably form a very substantial part of the capacity of any existing plant.
- If the NGL recovery plant was designed for sour gas (containing hydrogen sulphide), then the unit cost of processing sweet LNG (free of hydrogen sulphide) through it would likely be greater than the unit cost of processing LNG through a dedicated fractionation plant at the import terminal.

### Case Study 7.2 Blending in the Network, Crown Landing

An LNG import terminal was proposed by BP at Crown Landing on the East Coast of America. A study was commissioned to enable BP to quantify the extent of a range of potential effects on the end users to whom BP wanted to market LNG. The models developed in this study allowed BP to see the predicted 'zone of influence' of gas from the terminal. In turn, an assessment was made of which networks would be affected. In particular, transient models were used to identify rapid changes in gas quality at gas turbine power plants. The study provided information to help determine the appropriate sizing of a nitrogen ballasting plant for treating the imported gas.

The deliverable from this study is a simulation tool (using Stoner's SynerGEE Gas and pipeline simulator software) which can be used by BP or by other parties to do further analysis of similar issues within affected pipeline systems.

The conceptual approach was as follows:

- Obtain FERC submittals for 2003 (public domain info).
- Use the meter flow data and flow schematics to construct a SynerGEE Gas simulation model of the pipeline system in the affected region.
- Goal: A medium-fidelity model to do flow pattern prediction for the purpose of blending the LNG with the pipeline gas.
- Projecting forward to future demands and a wide range of operational conditions.
- Conduct simulations at various system demand levels, with various LNG types.
- Predict the specific gravity, Heating Value, and Wobbe Index at every customer in the pipeline system.
- Compare these against HV and Wobbe Index limits from the NGC to identify customers that are at risk.
- Use the simulator to estimate the revised LNG injection rate that will bring the delivered gas into acceptable limits.
- For each injection rate, examine whether that rate is achievable at an injection pressure of 1,000 psi.
- As a side goal, examine dynamic cases where the LNG injection rate changes, and then track how fast the Wobbe Index will change at a given customer.
- Dynamically estimate nitrogen ballasting requirements at the terminal to ensure that there are no problems for end users.

### 7.3.1 Ballasting

#### Point of production – Upstream

**Ballasting is a technique to lower the Wobbe Index and Heating Value of rich natural gas by the addition of a readily available gas (e.g. nitrogen, carbon dioxide, air, hydrogen) such that the quality of send-out gas from a terminal meets customer requirements. The degree of adjustment is often limited by the allowable concentration of a specific component.**

- **Ballasting with nitrogen is widely used for its strong effect on Wobbe Index.**
- **Air ballasting is very similar to nitrogen ballasting albeit with the disadvantage of introducing oxygen into the natural gas.**
- **High levels of hydrogen induce high flame speed and high diffusivity; therefore, hydrogen ballasting is limited to small changes.**

Note that most pipeline gas specifications include inert gas limits which may restrict the application of ballasting techniques and ballasting may be combined with other techniques e.g. blending.

- Nitrogen ballasting is the most widely applicable method and has the advantage of maintaining the positive aspects of re-gasified LNG as purified natural gas stream, i.e. very low levels of carbon dioxide, oxygen and water.
- Ballasting with air is likely to be the cheapest method but the application of this technique is restricted by limits on the maximum allowable oxygen in natural gas (typically 0.2%) and is only used for small adjustments.
- Ballasting with other gases such as carbon dioxide is technically feasible but unlikely to be cost effective when compared to ballasting with nitrogen or air. Carbon dioxide can be dismissed based on the large quantity required and its impact as a greenhouse gas. Hydrogen could be used where small adjustments are required.

#### Ballasting with Nitrogen

Nitrogen ballasting has a particularly strong effect on Wobbe Index. The addition of nitrogen to LNG reduces the Higher Heating Value of re-gasified LNG because nitrogen is an inert gas. The addition of nitrogen increases the Relative Density of natural gas. This is because the Specific Gravity of nitrogen is 0.969, which is significantly higher than the Relative Density of methane, which is 0.556. The net results of adding nitrogen to natural gas are therefore to reduce the Higher Heating Value and increase the Relative Density, both leading to a reduction in Wobbe Index.

#### Nitrogen Generation Technologies

Ballasting with nitrogen can be an extremely effective way of adjusting LNG quality; however, it is of course necessary to first secure a supply of nitrogen. Nitrogen is typically obtained from air using one of three techniques:

- Gaseous and/or liquid nitrogen can be produced following separation from oxygen in the air by cryogenic distillation. This relatively high cost technique can economically produce nitrogen of virtually 100% purity (i.e. 100 ppb oxygen) at rates of the order of several hundred Nm<sup>3</sup>/h. Lower purity nitrogen (e.g. 99.9995%) can be economically produced using this technology at rates of the order of several thousand to tens of thousand Nm<sup>3</sup>/h.
- Gaseous nitrogen can be produced following separation from oxygen in the air by permeation using membrane technology. This relatively low cost technique can economically produce nitrogen with up to 99.9% purity (i.e. 0.1% oxygen) at rates of the order of several hundred Nm<sup>3</sup>/h. Lower purity nitrogen (e.g. around 95%) can be economically produced using this technology at rates of the order of several thousand Nm<sup>3</sup>/h.
- Gaseous nitrogen can be produced following separation from oxygen in the air by pressure swing adsorption (PSA). This intermediate cost technique can economically produce nitrogen with 99.9995% purity (i.e. 5 ppm oxygen) at rates of the order of several hundred Nm<sup>3</sup>/h. Lower purity nitrogen (e.g. 99.9%) can be economically produced using this technology at rates of the order of several thousand Nm<sup>3</sup>/h.
- Inert gas production by combustion (if oxygen content of 50ppm is allowed in the send-out).

The choice of technology will depend on a number of factors including costs versus purity requirement, availability, start-up time and delivery logistics. In the case of the UK for instance, which requires a very lean LNG and has a very tight oxygen specification, nitrogen production by cryogenic air separation is virtually the only option.

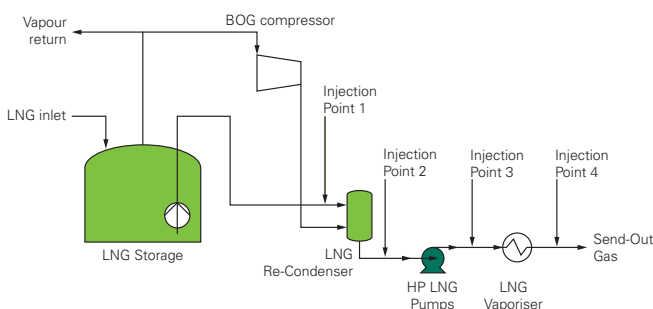
At many terminals it might not be possible to continue gas send-out if the terminal's nitrogen ballasting system were unavailable, in which case a reliable nitrogen supply would be of paramount importance. Fortunately, nitrogen generation technology is well proven and relatively reliable. The implementation options and measures to enhance the reliability are shown in Table 7.6.

**Table 7.6 – Installation of Nitrogen Facilities.**

Implementation Options	Reliability Improvement
<ul style="list-style-type: none"> <li>Dedicated nitrogen generation facilities located on or adjacent to the LNG import terminal. Additional oxygen sales possible.</li> </ul>	<ul style="list-style-type: none"> <li>Parallel installation of nitrogen generation trains, including a spare unit.</li> </ul>
<ul style="list-style-type: none"> <li>Shared nitrogen generation facilities. This could also supply gaseous/liquid nitrogen to other users.</li> </ul>	<ul style="list-style-type: none"> <li>Installation of cryogenic distillation plant to produce liquid (for back-up) and gaseous (for normal operation) nitrogen.</li> </ul>
<ul style="list-style-type: none"> <li>Liquid nitrogen delivered by road tanker and stored on site. Gaseous nitrogen could also be supplied by pipeline.</li> </ul>	<ul style="list-style-type: none"> <li>Setting up agreements and facilities to allow quick delivery of nitrogen by road tanker as backup for on-site generation.</li> </ul>

Trucking nitrogen is relatively expensive and only suitable for small quantities or intermittent use with occasional rich LNG cargoes. Clearly, all options will not be practicable for all locations or projects. The UK for instance, has a very well developed liquid nitrogen production and distribution system, in addition to well developed industry and infrastructure. As a consequence, there are likely to be few opportunities for integration between sites within the UK. In developing countries on the other hand, where industry in general and specialist gases companies such as Air Products, Air Liquide and Linde/BOC may be looking to expand, there may be some opportunities for integration.

In addition to the choice of nitrogen production technology and how it is applied, the point at which the nitrogen is to be injected is an interrelated and key decision. There are different locations that could be considered and these are shown in Figure 7.7.



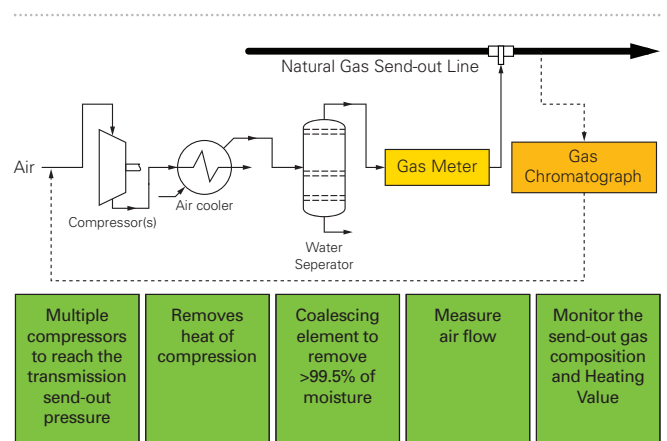
**Figure 7.7 – Potential Nitrogen Injection Points.**

Finally, consideration should need to be given to the best way of operating the nitrogen generation plant. In many instances, it may make more sense to have an operations agreement with the technology provider, rather than using staff from the LNG import terminal to operate the plant.

### Ballasting with Air

Air contains approximately 79% nitrogen and 21% oxygen, so the effect of air ballasting on the properties of natural gas is very similar to the effect of nitrogen ballasting.

Air ballasting is typically achieved by using one or more compressors to inject air into the natural gas send-out line through a mixing nozzle, as illustrated in the diagram below:



**Figure 7.8 – Air Ballasting System.**

Customers (e.g. pipeline owners/operators) typically have two main areas of concern when receiving natural gas that has been ballasted with air:

- The total percentage of oxygen, and
- The water dew point of the natural gas send-out stream.

### Case Study 7.3 Ballasting with Oxygen

UK GS(M)R currently restricts oxygen content to 0.2 mol%. If 4 mol% of air were added for ballasting purposes, the approximate resultant oxygen content would be 0.8 mol%. This would exceed the current GS(M)R specification.

Air ballasting is, therefore, limited to applications where only about 1 mol% of air is required to meet the Wobbe Index maximum specification. This would only be suitable for LNG imports into the UK with a Wobbe Index less than 52.0 MJ/m<sup>3</sup> of which there are only a limited few sources worldwide.

### Issues with Air Ballasting

The primary concerns with regards to air ballasting are safety and corrosion, although there are other potential issues. Some important points to bear in mind include:

- When ballasting with air, the maximum amount of injected air should be limited such that a flammable mixture is not reached in the system. As such, the mixture of air and natural gas should contain no more than 3 vol% oxygen. This process would produce safety risks because excess ballasting with air (e.g. caused by equipment malfunction) could result in the formation of possible flammable gas mixtures in networks.
- Corrosion of pipelines can occur in the presence of free oxygen and moisture. The water content of air increases with ambient temperature and so is usually only an issue on the hottest days of the year.
- Underground storage facilities, LNG peak shaving liquefiers and certain chemical plants may also be sensitive to oxygen levels due to poisoning of molecular sieves.
- Other potential issues include the interaction of free oxygen with other compounds present in the gas stream. For example, high sulphur content gas combined with oxygen and sufficient moisture can lead to the formation of sulphuric acid, or can be associated with the formation of crystallized sulphur.

It is worth noting that different customers and markets have very different specifications and air ballasting can only be performed where gas quality specifications permit. Even when permitted by the relevant quality specifications, it is critical that coordination is undertaken with stakeholders (e.g. other shippers and distribution companies) prior to any form of air ballasting, in order to address/manage their concerns.

- In the early days of the LNG Industry, the UK, USA and France, for example, used air ballasting at Canvey Island, Everett and at Montoir respectively.
- The UK and parts of the USA now have very strict oxygen specifications (due to the presence of LNG peak shaving plants) that make it impractical to ballast with air. The EASEE-gas draft specification limits oxygen to a very low 10 ppm.

### Ballasting with Hydrogen

Hydrogen can be used to decrease Wobbe Index. The UK National Transmission System (NTS) entry specification and GS(M)R currently only permit 0.1 mol% of hydrogen. Addition of this quantity of hydrogen has a negligible effect on the Wobbe Index. Even an addition of 4 mol% hydrogen would only reduce the Wobbe Index by about 0.5 MJ/m<sup>3</sup> as shown in the Dutton diagram in Figure 7.9. Addition of about 15 mol% would be required to correct the Wobbe Index of Nigeria LNG to meet the UK GS(M)R Wobbe Index limit. It is therefore concluded that ballasting with hydrogen alone would not be practical.

Nevertheless, hydrogen may ultimately be acceptable as a constituent of natural gas at concentrations up to around 5%. Higher levels are problematic to varying degrees due to high flame speed and high diffusivity. This rules out use for large changes but it could be possible where only a small decrease in Wobbe Index (by about 0.5 MJ/m<sup>3</sup>) is required.

At present there are other practical limitations to transportation of hydrogen mixtures in high- pressure natural gas transportation systems, which are the subject of large research projects throughout Europe. Additionally the costs of production, storage and transportation of hydrogen are currently prohibitive (but likely to fall as technology is developed).

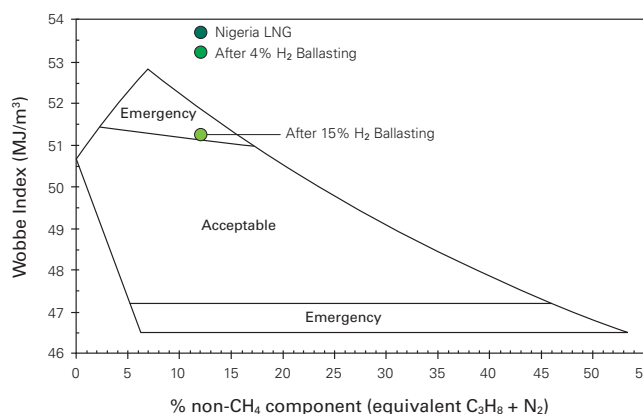


Figure 7.9: Effect of Blending LNG with Hydrogen.

### Ballasting with Other Gases

It is possible to ballast with other gases; however, it is not thought that this has actually been done in an import terminal. The main reason for this is that it is unlikely that another gas would be available at a location in sufficient quantity and at a low enough price to compete with nitrogen and/or air. It is possible to envisage a gas such as carbon dioxide being added after the LNG has been heated or re-gasified (i.e. to avoid freezing), but in most cases the amount of potential ballasting would be quite strictly limited by the gas quality specification. Furthermore, it would take a very special situation to make such a scheme economic.



## 7.3.2 Liquefied Petroleum Gas (LPG) or Natural Gas Liquid (NGL) Removal

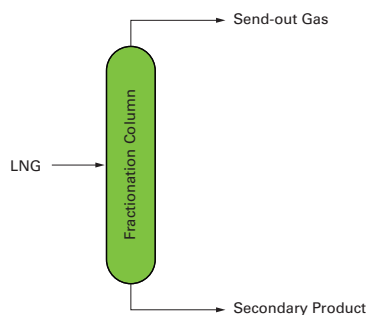
### Point of production – Upstream

**LPG and NGL removal from LNG are standard fractionation processes, except that the operating temperatures involved for LNG are substantially lower than most other fractionation processes. For rich feed gas streams, it is standard practice for the LNG plant to remove NGLs (LPGs and/or condensate).**

### LPG Removal from LNG

It is possible to design a process to separate as many LNG components as desired. Fractionation of LNG normally does not involve the production of side-streams, only top and bottom product streams.

- In the simplest process, in which it is desired only to separate light components (e.g. nitrogen, methane and ethane) from heavier components, only a single distillation column is required.
- In a more complicated process, a system of four distillation columns can be used in series to produce products consisting predominantly of methane, ethane, propane, butane and pentane. This type of scheme was used at the Barcelona LNG Terminal.



**Figure 7.10:** Simplified Flow Diagram of Single Column LNG Fractionation.

LNG lends itself to distillation in that it is a liquid feedstock and the top product is gaseous, so if this is the primary product stream then no re-gasification is required prior to send-out. Also, depending on circumstances it may be feasible to set the operating pressure of the distillation column to match that of the gas transmission/distribution system that is being supplied.

### Issues with LNG Fractionation

- At high pressures (perhaps 70 - 80 bar) the LNG mix may be a dense phase fluid and non-separable. LPG separation is more normally done at low pressure after the in-tank pumps with a total condenser to produce two liquid products.
- One aspect of LNG that is unfavourable for fractionation is the heat required to pre-heat the LNG feed to a distillation column and/or the reboiler. The easiest way to supply this heat and control the process is by using steam, but unless steam is available from an off-site source (e.g. from an adjacent power station or industrial complex), then operation of a steam boiler system will be required, which will incur additional capital and operating costs.
- A further disadvantage of applying fractionation at an import terminal is that it has the potential to limit the turndown capability of the send-out section.

For reasons of reliability, an additional nitrogen injection facility may be necessary for dealing with the maintenance periods of LPG removal units and nitrogen injection could also complement the fractionation in the case of spot rich LNG cargoes going out of the design specifications of the fractionation units.

For NGL removal schemes, there is also a requirement for LPG/condensate storage on site.

### LPG Fractionation Plants at LNG Terminals

Although there are currently no examples of these processes in operation at LNG import terminals, such a solution could be economical in the future, especially in regions where there is an active LPG demand and, even more importantly, a market for ethane.

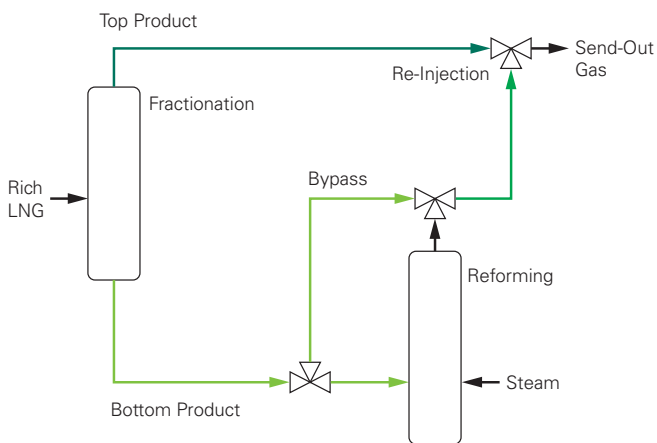
- In India the Dahej LNG Import Terminal has an associated plant external to the terminal to extract C<sub>2</sub>+ components by a cryogenic process which is in operation. This plant is not required for heating value modification but because it is profitable to remove the LPG for sale.

## Reforming of LNG Product Streams

Reforming refers to the reaction of hydrocarbons with steam. The purpose of the process is to convert a hydrocarbon stream with higher average molecular weight into a hydrocarbon stream with lower average molecular weight. The main reactions are:



In the context of LNG quality adjustment, this allows a heavy LNG fractionation product stream (e.g. consisting primarily of propane and butane) with a relatively high Heating Value to be converted into a stream with a relatively low Heating Value. This stream could then be recombined with a light LNG fractionation product stream to form a relatively lean send-out gas.



**Figure 7.11** – Simplified Flow Diagram of LNG Fractionation and Reforming.

Reforming was historically one of the main sources of synthetic natural gas (as an alternative to coal-gas) prior to the general utilisation of natural gas in Europe. In the process, a hydrocarbon reacts with steam in the presence of a catalyst. The reaction occurs at a relatively high temperature, usually over 600°C, and often only reaching completion around 1,000°C.

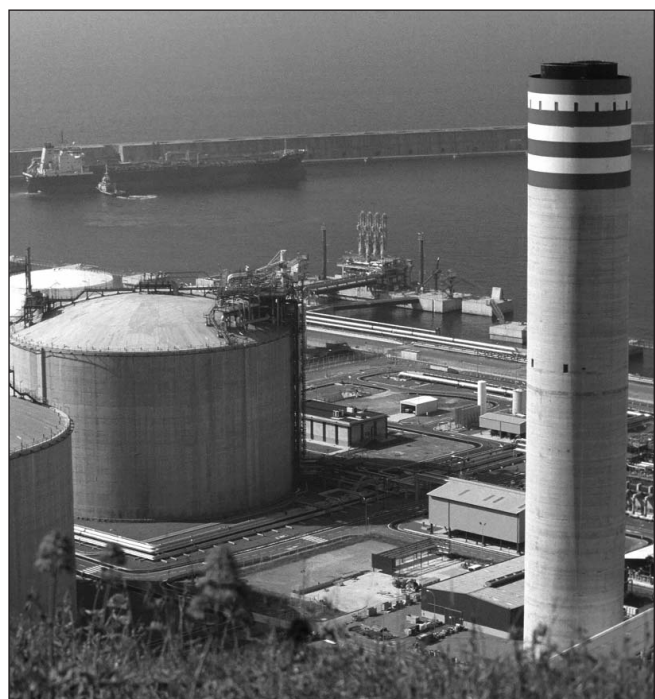
Reforming is highly endothermic. Delivery of heat to the reaction is a key technical issue.

More steam is required as the average molecular weight of the feedstock increases and cracking of higher hydrocarbons can also cause problems of carbon formation. The LNG also needs to be relatively free of sulphur compounds (ppm levels) to avoid poisoning of conventional reforming catalysts. Therefore reforming is most suited to sweet, relatively light LNG.

## Issues with Reformed LNG Product Streams

The re-injection of a reformed LNG product stream, which is composed essentially of hydrogen, carbon monoxide and carbon dioxide, presents a number of issues:

- Most reforming processes operate at pressures of 20 - 40 bara. Typical gas transmission systems require gas at a higher pressure, so it is likely that gas compression would be required.
- The various reforming processes operate at very high temperatures; typically around 400 - 500°C, so in most cases it would be necessary to cool the gas prior to mixing. In order to optimise the process, a high degree of heat integration would clearly be advantageous, at the cost of increased complexity.
- Reforming allows the Heating Value and Wobbe Index of a send-out gas stream to be reduced by increasing the proportion of reformed gas to non-reformed gas in that stream. However, the maximum proportion of reformed gas to non-reformed gas in the send-out stream will probably be limited by market specifications for hydrogen, carbon monoxide and/or carbon dioxide. Most gas markets have specifications limiting some or all of these components and the specifications can be tight (e.g. the UK limits hydrogen to less than 0.1 mol%).



### 7.4.1 LPG injection

#### Point of production – Upstream

**LPG (in both its liquid and gasified forms) can be injected into a natural gas or LNG stream to increase its Wobbe Index. One major issue with LPG injection is the increased hydrocarbon dewpoint which could result in condensation into local distribution systems after pressure letdown. Therefore, this is only practical for small corrections.**

For mid-stream and downstream LPG injection is the most common and generally most cost effective method of enrichment. It is widely used in Japan.

The addition of 10% propane to methane (at 15°C) has the effect of increasing Wobbe Index by about 6%. An equivalent amount of butane will increase the Wobbe Index by 8%. Heating Value is increased by 15% and 19% respectively.

The LPG that is injected can include commercial LPG (typically 75% propane, 25% butane mix) or commercial propane (containing approximately 3% butane). Approximately 1.2 mol% addition of LPG is required to increase the Wobbe Index by 0.5 MJ/m<sup>3</sup>. The hydrocarbon dewpoint would also be increased by about 4°C for this case, which in most cases would easily be accommodated without exceeding export gas quality specification. This is equivalent to about 250 tonnes/d of LPG per 10 mscmd of flow. This is a large quantity of LPG and is equivalent to at least 12 road tankers per day. This is likely to mean that such a scheme may need to be supplied either by pipeline, ship or rail.



#### Issues with LPG Injection

Although Wobbe Index can be corrected using LPG injection, such a scheme is likely to be considered unfeasible in many markets around the world for several reasons:

- The quantities of LPG required are very large which mean extremely high overall operating costs when the LPG supply costs are included (LPG costs are usually substantially higher than natural gas costs).
- The quantities of LPG required would raise concerns over a secure LPG supply. As an example, a typical UK oil refinery only produces around several hundred tonnes for export per day, with a total UK supply of around 15,000 tonnes per day.
- The addition of significant concentrations of LPG would cause problems meeting hydrocarbon dewpoint specification. The hydrocarbon dewpoint would rise by about 20°C by adding about 6.5 mol% of LPG. This could result in liquid formation through condensation.

Regarding this last point, this may be mitigated by blending with gases inside the hydrocarbon dewpoint specification, although this would not be guaranteed. Effective blending is feasible because natural gas undergoes “retrograde condensation,” which means that the maximum hydrocarbon dewpoint is only realised at the cricondentherm pressure, which typically occurs around 28 bar. This would only occur after pressure letdown facilities into local distribution systems and therefore would be distant from the network entry points.

Where liquids would form, their presence in the transmission network can cause damage to control, sampling and measurement systems whilst contamination of metering installations will generate metering errors. In all cases the immediate impact is a reduction in operational efficiency with a consequential increase in maintenance of affected installations and equipment.

Use of commercial propane instead of LPG will reduce the dewpoint effect. However, the quantities required would increase further, as propane has a lower Wobbe Index than butane, and is therefore less effective for Wobbe Index correction purposes.

It is therefore envisaged that although LPG injection could correct for all Wobbe Index modifications, in practice it would only be likely to be used for small corrections.

There are a number of options for injecting LPG:

- Addition of LPG to Re-gasified LNG.
- Addition of Gasified LPG to Re-gasified LNG.
- Addition of LPG to LNG.

### Addition of Vaporised LPG to Re-Gasified LNG

The conventional method of enrichment in Japan is to re-gasify LPG and inject it into a re-gasified LNG stream to produce a richer send-out gas. In order to achieve this, it is necessary to heat the LPG typically using steam.

Advantages of this method are:

- As it adds LPG as gas, the amount of LPG that can be injected is only limited by the availability of LPG and the capacity of associated equipment (e.g. LPG pumps and LPG vaporisers).
- There is no risk of solidification of LPG components and additives.

A disadvantage of this method is that if steam or another heating medium is not readily available from an off-site source (e.g. from an adjacent power station or industrial complex), then operation of a heating system will be required, which will incur additional costs.

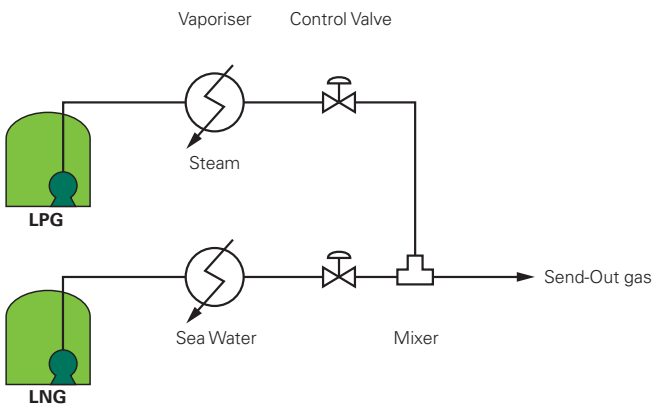


Figure 7.12 – Gas/Gas Enrichment.

### Addition of Liquid LPG to Re-Gasified LNG

A second method of enrichment used in Japan is to inject LPG into a re-gasified LNG stream using the heat in the re-gasified LNG to gasify the LPG.

Advantages of this method are:

- It removes the requirement for an additional heat source, reducing the amount of equipment required and associated costs.
- As with the conventional method, there is no risk of solidification of LPG components and additives.

A disadvantage of this method is that as it adds LPG in liquid form, the amount of potential quality adjustment is limited not only by the availability of LPG and the capacity of associated equipment (e.g. LPG pumps), but also by the temperature of the re-gasified LNG.

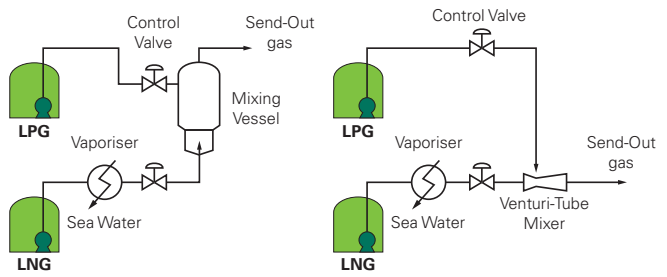
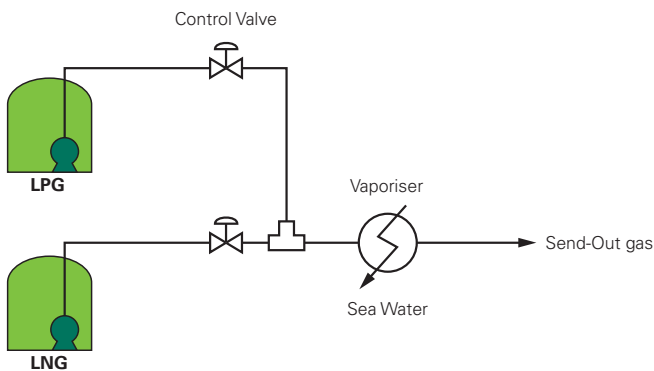


Figure 7.13 – Gas/LPG Enrichment Methods.



### Addition of LPG to LNG

A third method of enrichment is to inject LPG into the LNG stream upstream of the LNG vaporiser. This may become the preferred method in Japan.



**Figure 7.14** – LNG/LPG Enrichment.

Advantages of this method are:

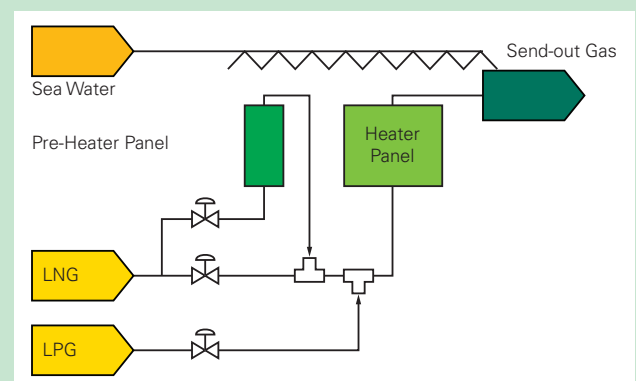
- As LPG is added in liquid form upstream of the LNG vaporiser, the amount of LPG that can be injected and hence the amount of potential quality adjustment that can be achieved is limited only by the availability of LPG, the maximum capacity of the LPG pump(s), the maximum duty of the LNG vaporiser and the rate of gas send-out.
- No additional heat source is required and the system is simple to operate.

A disadvantage of this method is that during a rapid load change on a conventional Open Rack Vaporiser (ORV), the Heating Value of the send-out gas will fluctuate as a result of the concentration of the LNG/LPG mixture at the lower header of the ORV panel(s). This is largely due to the difference in flow characteristics of the different gaseous and liquid components through the vaporiser.

A further disadvantage of this method is that LPG contains predominantly propane, butane or a mixture of the two components and may also contain additives such as methanol (e.g. for hydrate inhibition). Butane and some additives freeze at a higher temperature than LNG and so there is a risk of solidification and deposition, potentially causing blockage of downstream piping and equipment.

### Case Study 7.4 LPG/LNG Enrichment in Japan

In Japan, it has been found that uniformity of LNG and LPG mixing is important in order to avoid high localized concentrations of some LPG components. Also, a system is used whereby the temperature of LNG is raised to approximately  $-130^{\circ}\text{C}$  prior to injection of LPG. This is achieved in Japan by pre-heating and re-gasifying a side stream of LNG and re-injecting it into the main LNG stream prior to injection of LPG and re-gasification of the LNG/LPG mixture.



**Figure 7.15** – Outline of ORV with LNG/LPG Enrichment.

The pre-heating and re-gasification steps can take place in the same ORV. This is reported to increase the cost of the ORV by about 30%. However, the operating costs are reported to be about 10% of the operating costs of a conventional system utilising steam giving a payback of only 1.5 years assuming that the LNG is being enriched from  $38 \text{ MJ/Nm}^3$  to  $46 \text{ MJ/Nm}^3$  and the ORV has an annual average operating load of 60%.

## 7.4.2 Inert or Carbon Dioxide Removal

### Point of production – Upstream

Carbon dioxide removal is only applicable to pipeline gas as LNG contains no carbon dioxide. Removal could be based on amine absorption, solid bed adsorption or membrane separation. It is economical and efficient for small adjustment of Wobbe Index. The process of nitrogen removal by cryogenic distillation is more complex, as it requires upstream elimination of carbon dioxide and water which have lower boiling points. This technique is used to adjust gas quality which is beyond the capacity of carbon dioxide removal.

Since LNG has virtually zero carbon dioxide content, the carbon dioxide or nitrogen removal method is only applicable for adjustment of pipeline gas quality prior to entry into a transmission system.

### Carbon Dioxide (CO<sub>2</sub>) Removal

The two inert gases that are normally removed from natural gas streams are carbon dioxide and nitrogen. Carbon dioxide removal is a common unit operation on gas processing facilities with established technologies. Where only a small adjustment of Wobbe Index is required, carbon dioxide removal will usually be sufficient and it is therefore preferred to the more expensive nitrogen removal processes such as a cryogenic plant. Indeed, the cryogenic nitrogen removal plant requires prior removal of carbon dioxide and dehydration to prevent blockage.

There is a choice of carbon dioxide removal methods depending on the scale, feed gas concentration and product gas specification:

- Liquid Absorption (e.g. amines).
- Solid Bed Adsorption (molecular sieve).
- Membranes.

Liquid absorption is preferred for large scale operation and the selectivity of the carbon dioxide removal. Figure 7.16 shows a typical process flow diagram of such a unit.

It is estimated that removal of 0.24 mol% carbon dioxide from the gas stream reduces the Wobbe Index by 0.2 MJ/sm<sup>3</sup>. Depending on the carbon dioxide composition of the imported gas, only part of the gas stream need be fed into the carbon dioxide removal unit before it is mixed back with the main stream, thereby reducing capital/operating costs.

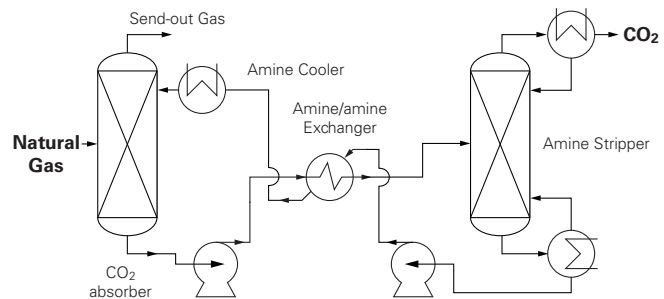


Figure 7.16 – Amine Absorption Process for CO<sub>2</sub> Removal.

### Nitrogen (N<sub>2</sub>) Removal

Nitrogen is usually only removed from natural gas streams where the acceptable nitrogen (or total inerts) specification is exceeded. For the UK this corresponds to 5 mol% nitrogen and 7 mol% total inerts. The only viable technique for nitrogen removal at large gas flow-rates (> 1.4 mscmd) is cryogenic nitrogen rejection. The process requires upstream carbon dioxide removal (absorption) and dehydration (adsorption or glycol) to eliminate the possibility of freezing of carbon dioxide and water in the cryogenic plant.

The cryogenic type of nitrogen rejection plant liquefies all of the natural gas stream (nitrogen has a lower boiling point than methane) and then separates the nitrogen by cryogenic distillation. Hydrocarbons are subsequently released by raising temperature. As the process produces the hydrocarbons at low pressure, the stream therefore requires re-compression back to the export gas pressure.

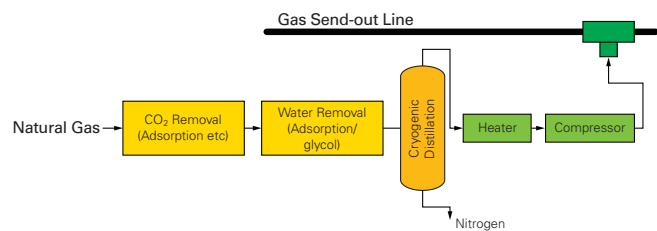


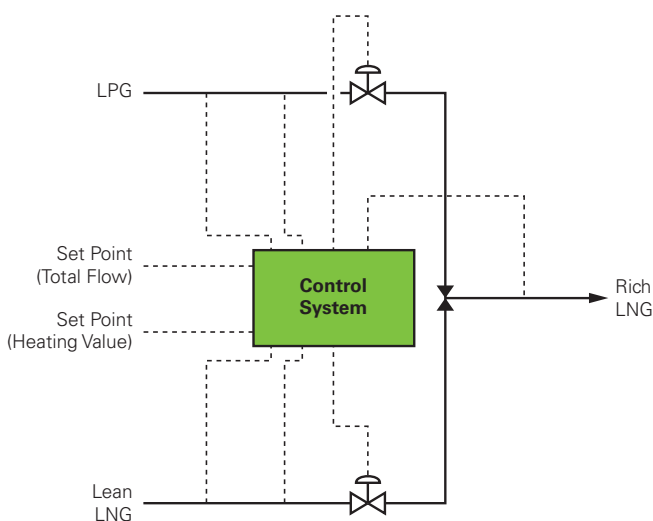
Figure 7.17 – Nitrogen Removal Flow Diagram.

The heat exchanger and compressor requirements make the plants complex and they have been reported to suffer reliability issues on some sites. These issues make the process highly costly and therefore it is only normally used where there are no other process routes.

**It is important to monitor the send-out gas quality constantly, particularly at an LNG terminal, where the pipeline gas quality specification range is relatively narrow.**

Unlike imported pipeline gas for which gas quality is usually known and delivered within an agreed range, the quality of LNG can vary between cargoes from different sources as well as with storage period. In LNG quality adjustment operations, the method of controlling send-out gas quality is of paramount importance. If there is no intermediate storage prior to sale, it is very important that a system is in place to continuously monitor and adjust parameters such that all send out gas meets the quality specification. The time taken to analyse the gas in the send-out pipeline of a LNG import terminal can be an issue if it is not rapid enough to detect off-spec gas entering the transmission network.

During enrichment operations in Japan, Heating Value is adjusted using dual control. LPG injection rate is controlled on a feed-forward basis based on LNG flow rate, LNG Heating Value and LPG Heating Value. LPG injection rate is corrected on a feed-back basis based upon the measured Heating Value of the re-gasified LNG/LPG mixture. A simplified control scheme is shown below.



**Figure 7.18** – Simplified Control Scheme for LNG Enrichment with LPG.

The same type of control scheme can be used for LNG blending in the send-out section of an import terminal.

### Case Study 7.5 Options for Quality Adjustment for Rich and Lean Gases to Japan and the USA

As discussed in Chapter 5, LNG composition varies widely between different sources. Two compositions have been chosen corresponding to LNG sourced from Alaska (Kenai plant), which is extremely lean (almost pure methane) and LNG sourced from Algeria (Arzew GL1Z & GL4Z), which is relatively rich.

Many new liquefaction projects are designed to produce a quality somewhere in-between the Kenai quality and the Arzew quality to increase product acceptability.

**Table 7.2** – Example Lean and Rich LNG Compositions.

Parameter	Lean LNG	Rich LNG
Higher Heating Value (MJ/m <sup>3</sup> )	37.74	2.04
Wobbe Index (MJ/m <sup>3</sup> )	50.60	52.75
Incomplete Combustion Factor	-0.08	1.46
Soot Index	0.49	0.61
Nitrogen (mol%)	0.20	0.71
Methane (mol%)	99.72	86.98
Ethane (mol%)	0.06	9.35
Propane (mol%)	0.01	2.33
Butane (mol%)	0.01	0.63

#### Notes:

- Both combustion and metering conditions are expressed at standard conditions of 15°C and 1.01325 bara.
- Higher Heating Value and Wobbe Index calculated for a 'real gas'.

### (a) USA

Table 7.3 shows the send-out gas quality requirements for Elba Island in the USA which requires relatively lean gas, but in other respects is relatively flexible. Comparison of this table with the example lean and rich LNG compositions shows that the example lean gas complies with the specification, whereas the rich LNG will not comply with the specification without quality adjustment.

**Table 7.3 – Quality Specifications for Send-Out Gas at Elba Island.**

Parameter	Specification
Higher Heating Value	37.74 (MJ/m <sup>3</sup> )
Higher Heating Value	37.17 - 39.95 MJ/m <sup>3</sup>
Oxygen	≤ 1.00 mol%
Carbon dioxide	≤ 3.00 mol%
Nitrogen	≤ 3.00 mol%
Mercaptans	< 200 grains
Total sulphur (S), including hydrogen sulphide, carbonyl sulphide and mercaptans, but excluding sulphur of odorant	< 200 grains

Notes:

- Both combustion and metering conditions are expressed at standard conditions of 15°C and 1.01325 bara. Where necessary, original specifications have been converted to this basis.
- Specifications relating to sulphur compounds are expressed in terms of elemental sulphur content.
- The sulphur specifications are unclear with regards to whether they are quoted on a volume basis or a mass basis and which units should be used (e.g. grains/Nm<sup>3</sup>, grains/te). However, as this area of uncertainty is not relevant to the example, it has been ignored.

In order for the example rich LNG to comply with the Elba Island specification, the Heating Value will need to be reduced prior to send-out. This could be achieved by blending, ballasting, fractionation or reforming.

As the example rich LNG is only slightly out of specification, blending in the local pipeline network could potentially be feasible, provided there is a local gas production supplied by a pipeline which is connected to the send-out pipeline of the LNG terminal, upstream of any gas consumer. In any event this would need to be discussed with the pipeline company.

**Blending** – Blending of different LNG qualities at the import terminal is also feasible and if, say, the example lean LNG were to be blended with the example rich LNG, a 1:1 mixture (expressed in molar terms) would have a Higher Heating Value of 38.98 MJ/m<sup>3</sup>, meeting the specification. If it was decided to follow the blending route, then qualitative considerations suggest that in-tank blending would likely be preferable to blending in the send-out section of the terminal as separate storage would not then be required. Careful management is critical for an in-tank blending operation to avoid stratification and rollover effects which will result in generation of a large volume of BOG (see Section 4.2.4 for further details).

**Ballasting** – Air or nitrogen ballasting alone is not feasible because the maximum nitrogen specification (≤3 mol%) will be exceeded before the Heating Value requirement is met. As the oxygen limit is relatively high, the potential for air ballasting is greater than the potential for nitrogen ballasting. Using the example lean LNG as a reference gas, the effect of nitrogen and air ballasting have been investigated and summarised in Table 7.4.

**Table 7.4 – Impacts of Nitrogen and Air Ballasting on an Example Rich LNG.**

	Rich LNG	Ballasted with: N <sub>2</sub>	Air
Nitrogen/air added (mol%)		2.35	3.05
Methane	86.98	84.97	84.41
Ethane	9.35	9.13	9.07
Propane	2.33	2.28	2.26
Butane	0.63	0.62	0.61
Nitrogen	0.71	3.00	3.00
Oxygen	—	—	0.62
Argon	—	—	0.03
Higher Heating Value (MJ/m <sup>3</sup> )	42.04	41.07	40.79
Wobbe Index (MJ/m <sup>3</sup> )	52.75	51.22	50.75

**Fractionation** – It is possible to use one or more fractionation columns to produce a product stream that complies with the specification. However, a use or market would be required for the product stream(s) containing heavier components such as propane and butane. NGL recovery is common in the USA, but the feasibility and design would depend very much on the specifics of the project. Fractionation and/or reforming are also feasible given that the Elba Island specification does not include a limit on hydrogen or carbon monoxide content. Table 7.5 gives details of an example of a simplified fractionation and reforming operation for the rich LNG.



**Table 7.5** – Example Fractionation and Reforming Operation.

Parameter	LNG Feed to Column	Column Top Product	Column Bottom Product	Reformed Bottom Product	Send-Out Gas (No Bypass)	Send-Out Gas (60% Bypass)
Higher Heating Value (MJ/m <sup>3</sup> )	42.04	40.24	93.05	12.06	32.80	37.74
Nitrogen (mol%)	0.71	0.74	0.00	-	0.54	0.64
Carbon Monoxide (mol%)	-	-	-	29.91	7.88	3.67
Hydrogen (mol%)	-	-	-	70.09	18.47	8.61
Methane (mol%)	86.98	89.82	8.07	-	66.14	77.24
Ethane (mol%)	9.35	9.32	10.09	-	6.87	8.19
Propane (mol%)	2.33	0.10	64.27	-	0.08	1.30
Butane (mol%)	0.63	0.02	17.58	-	0.02	0.35

Notes:

- (a) Both combustion and metering conditions are expressed at standard conditions of 15°C and 1.01325 bara.
- (b) As a simplification, only the reaction  $C_nH_m + nH_2O - nCO + (n+m/2)H_2$  is considered, where  $C_nH_m$  is the hydrocarbon equivalent to the composition of the inlet stream.
- (c) As a simplification, 100% selectivity and reforming efficiency is assumed.

It can be seen from Table 7.5 that the composition of the send-out gas is dependent on the bypass ratio used for the reformer unit. It is necessary to bypass part of the column bottom product stream around the reformer in order to avoid producing a send-out gas that has too low a heating value. The 60% bypass shown above allows the Elba Island specification to be comfortably achieved and an even higher bypass rate would be possible.

In conclusion, the quality of the example rich LNG could be adjusted to meet the Elba Island specification by blending, fractionation or fractionation and reforming. Ballasting alone would not allow the specification to be met, but it could conceivably be used in combination with one of the other methods.

#### (b) Japan

Table 7.6 gives send-out gas quality requirements for Fukuoka in Japan. This terminal has been selected as an example with a requirement for a particularly rich send-out gas. In this case neither the example lean LNG nor the example rich LNG would be suitable for send-out from Fukuoka without quality adjustment.

In order for the lean LNG to comply with the Fukuoka specification, the Higher Heating Value, Wobbe Index and proportion of heavier components all need to be increased prior to send-out. This could theoretically be achieved by blending, fractionation (without reforming) or enrichment. In order for the rich LNG to comply with the Fukuoka specification, only the heating value would need to be increased.

**Blending** – In order to meet the quality specification by blending, access to a very rich LNG (i.e. even richer than the example rich LNG) would be required.

## 7.6 Quality Correction Downstream of the Network

**Table 7.6** – Quality Specifications for Send-Out Gas at Fukuoka.

Parameter	Specification
Higher Heating Value	43.19 - 43.98 MJ/m <sup>3</sup>
Wobbe Index	52.72 - 54.60 MJ/m <sup>3</sup>
Nitrogen	≤ 1.00 mol%
Methane	86.00 ≤ Methane ≤ 91.00 mol%
Ethane to Pentane	10.00 ≤ Ethane to Pentane ≤ 15.00 mol%
Total sulphur (S), including hydrogen sulphide, carbonyl sulphide and mercaptans, but excluding sulphur of odorant	≤ 7.57 mg/m <sup>3</sup>

### Notes:

- Both combustion and metering conditions are expressed at standard conditions of 15°C and 1.01325 bara. Where necessary, original specifications have been converted to this basis.
- Specifications relating to sulphur compounds are expressed in terms of elemental sulphur content.

Fractionation of the example lean LNG or example rich LNG is also feasible and would require only one column (i.e. a de-methaniser) that would in this case produce a bottom product suitable for send-out. However, a use would be required for the top product, which would be very lean and consist primarily of methane. Given that the customer requires very rich gas, it is difficult to see where the top product could be used unless there was a user capable of burning lean gas at the import terminal or on an adjacent site.

LPG Injection – Enrichment of the example lean LNG with propane is feasible and it would require only around 1/9th the amount of propane as lean LNG (expressed in molar terms). Enrichment of the example lean LNG with butane alone is not feasible because the minimum C<sub>2+</sub> requirement cannot be achieved whilst also meeting the other specifications. Using a combination of propane and butane, enrichment of the example lean LNG is feasible.

Enrichment of the example rich LNG with propane, butane or a combination of the two is not feasible because the high ethane content means that the minimum methane specification is breached before the required Higher Heating Value is achieved.

Consideration of the above points suggests that enrichment, blending or a combination of the two techniques would be the best ways of meeting the Fukuoka specification.

**Instead of adjusting the gas quality, downstream management of gas interchangeability mainly involves control at the combustion points. This includes**

- **Property measurement for burner controls – Wobbe Index is often measured to control and optimise the air-to-fuel ratio through the burner.**
- **Feedback from combustion products – Control of engines through exhaust oxygen monitoring. ‘O<sub>2</sub> Trim Systems’ is an automatic flue gas monitoring system for the burner air supply adjustment.**
- **Adaptive engine tuning – This allows natural gas vehicles to be filled from a range of filling stations although it could be costly.**
- **Gas turbine blending – Localised controlled blending of two or more supplies for overall gas quality control. This has been proposed for large user such as combined cycle gas turbine (CCGT) power plant in Asia.**

The techniques for quality correction that can be employed on a local downstream utilisation process are similar to those that are used at import terminals for treatment of gas before transmission through high pressure pipelines. In addition for optimum utilisation more advanced control systems can be employed. Clearly this leads to two distinct approaches:

- Control the gas quality to ensure that it meets with the required specification for the process through blending and ballasting.
- Control the process using advanced control methods to ensure that the correct air:fuel ratio is maintained and the combustion process is optimised.

It is evident that to undertake the process control, accurate measurements of the gas quality or some characteristics of the overall process must be made and the information fed into the control systems either through a feedback loop or possibly a feed-forward approach.

The downstream approach for process control in dealing with variation in gas quality includes:

- Property measurement for burner controls.
- Feedback from combustion products.
- Adaptive engine tuning.
- Gas turbine blending or control of fuel properties.

### Case Study 7.6: Far East Power Generation

A power plant operator in the Far East was developing plans for the future mix of power generation facilities. They intended to replace natural gas supplied from an existing gas field, as primary fuel for power generation at a CCGT power station, where the prime movers were a bank of General Electric (GE) manufactured gas turbines, by introducing an alternative supply of natural gas, planned to be LNG.

A study of feasible options for modification of facilities at the power station to:

- Enable the move into the transition period where natural gas and LNG could be used simultaneously, either separately or concurrently, and
- Enable the move into the long term solution of using LNG only.

GE does not use Wobbe Index, per se, as a measure of the interchangeability of gas fuels on its turbines but uses a variant instead, known as the Modified Wobbe Index (MWI), which includes the temperature of the fuel gas entering the combustor.

$$MWI = LHV / \sqrt{SG_{gas}} \times T_{gas}$$

where: LHV = lower heating value of the gas fuel (Btu/scf)  
 $SG_{gas}$  = specific gravity of the gas fuel relative to air  
 $T_{gas}$  = absolute temperature of the gas fuel (°Rankine)

A number of options were considered such as continuing to use the existing burners or replacing some or all of them at different phases with burners suitable for unmodified LNG. For example, if the existing gas turbine burners are to feature in the ultimate outcome for the power station, the properties of the LNG would need be manipulated to bring the Modified Wobbe Index of the fuel gas into the range of the existing burners. Figure 7.19 shows, schematically, the options considered for manipulating the three variable parameters of Modified Wobbe Index, to decrease the Modified Wobbe Index of LNG, either independently or together.

The principal options feature:

- Increasing the fuel gas temperature, and/or
- Modify the fuel gas composition to derich the LNG
  - Mix with one or more lower Calorific Value gas(es).
  - Strip out higher calorific value components (i.e. LPGs) from the LNG.

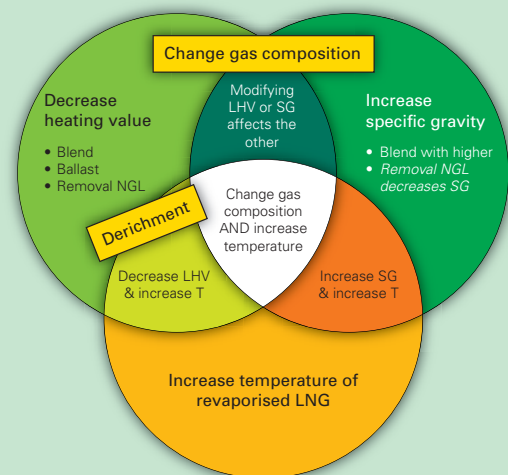


Figure 7.19 – Options for Modification of the Modified Wobbe Index of LNG.

The optimal ultimate long term solution recommended on a cost and ease of use basis for LNG firing was to convert all of the burners to LNG burners and do no gas processing.

### Property Measurement for Burner Controls

To overcome problems associated with variation in gas quality and composition, it is necessary to measure appropriate parameters to enable an additional control signal to be used. Whilst the ultimate goal would be a full gas composition analysis, with the output used to control and optimise the fuel and air flow through the burner, this is impractical and Wobbe Index is often used as a useful measure.

Calorific value, and hence Wobbe Index, is routinely measured on high-pressure transmission systems using process gas chromatography (Chapter 3) but these systems are expensive to install and maintain. For industrial control of Calorific Value and Wobbe Index, the response time of process gas chromatographs may be too slow when compared with the fluctuations in gas composition. A number of instruments have been developed to provide real-time measurements to incorporate into advanced control systems. Some instrument options are described below.

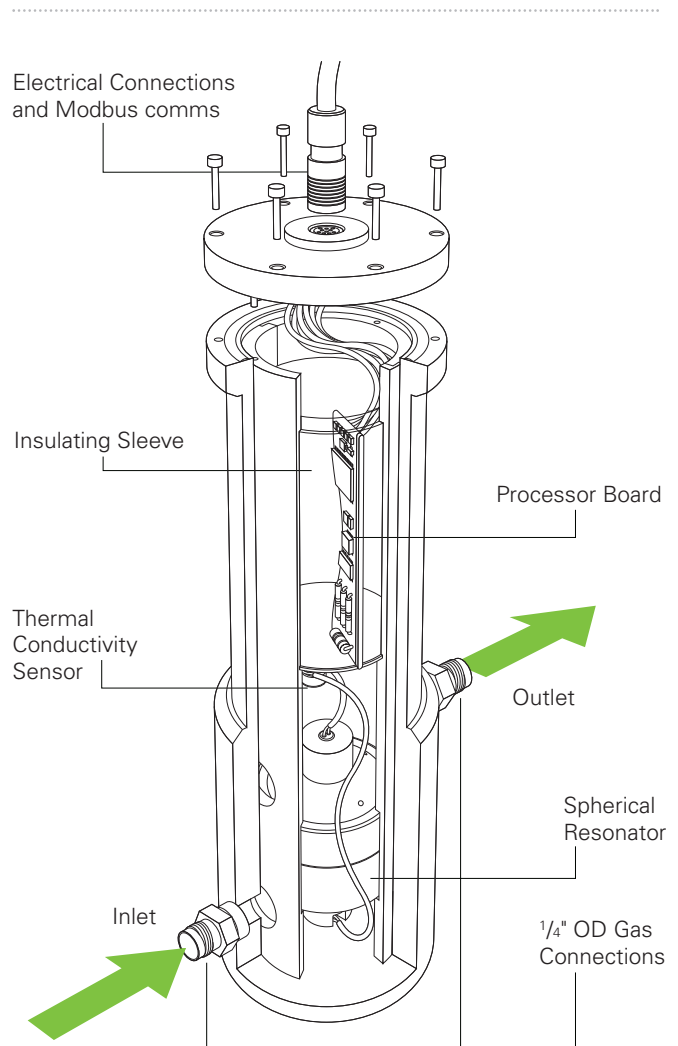
#### (a) GasPT

The GasPT was developed by Advantica. It determines Calorific Value, Relative Density and the effective gas composition expressed as methane, propane, carbon dioxide and nitrogen. The effective gas composition can be used to calculate a wide range of gas properties including Wobbe Index, density, compression factor, Motor Octane Number and Methane Number. The GasPT measures the speed of sound and the thermal conductivity at two temperatures and these two values are correlated with the gas composition. The speed of sound is measured with a specially developed spherical resonator. The 90% response time is 50 s although a change in gas quality can be detected in about 2 s.

The measurement uncertainties are:

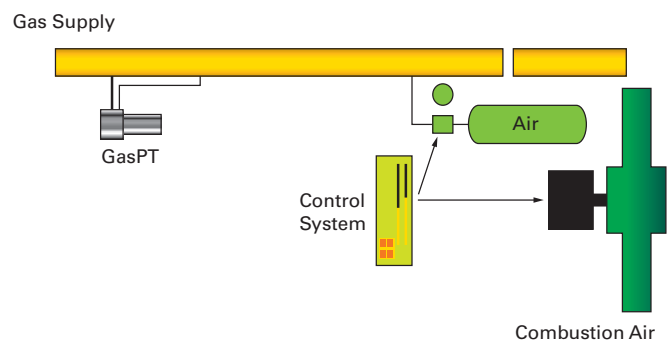
- Calorific Value  $\pm 0.5\%$  between 35.10 - 42.60 MJ/m<sup>3</sup> (9.7 - 11.8 kWh/m<sup>3</sup>) when calibrated for a specific range of gases.
- Relative density  $\pm 0.25\%$ .
- Temperature  $\pm 0.3^\circ\text{C}$  between -10 and 50°C.
- Pressure  $\pm 2$  mbar up to 1,300 mbar (absolute).

The Advantica GasPT unit and a typical installation are shown in Figure 7.20 and Figure 7.21.



**Figure 7.20** – The GasPT™

(Source: GL Industrial Services Ltd).



**Figure 7.21** – A Typical Set-up for a GasPT for Controlling Gas Quality.

### (b) Gas-lab Q1

The Gas-lab Q1 is manufactured by Flow Comp Systemtechnik and it reports Gross Calorific Value, density and the concentration of carbon dioxide. The Wobbe Index, Methane Number and a 10-component gas composition can also be derived. The instrument was developed by Ruhrgas, Sensors Europe GmbH and Flow Comp Systemtechnik GmbH.

The Gas-lab Q1 is a flameless gas quality analyser that operates using infrared absorption and thermal conductivity measurements. There are two infrared sensors, one of which is tuned to detect carbon dioxide only and the other to detect hydrocarbons, particularly ethane, propane and the butanes. The thermal conductivity sensor is strongly sensitive to methane and nitrogen.

As of 2010, Ruhrgas' plans are to use the Gas-lab Q1 as a control instrument in natural-gas blending stations and as a back-up instrument for process gas chromatographs. An application for approval under weights and measures legislation at PTB (The National Standards Laboratory) is underway in Germany and other applications will be filed in Europe and the USA.

The Gas-lab Q1 uncertainties are quoted as:

- Calorific Value <  $\pm 10.4\%$  between 34 - 45 MJ/m<sup>3</sup> (9.5 - 12.5 kWh/m<sup>3</sup>).
- Density < 0.8%.
- Carbon dioxide concentration < 0.2% for concentrations up to 5 mol%.

### (c) EMC 500

The EMC 500 is sold by the RMG group and it is a successor to the WOM 2000.

The instrument has two thermal sensors to measure heat capacity, viscosity and thermal conductivity, using these measurements to determine the Calorific Value. The gas density is calculated by measuring a pressure drop at constant temperature. The concentration of carbon dioxide (up to 20 mol%) is determined using an infrared sensor. A calibration gas with known Calorific Value and density is required for the initial and periodic calibration. The 90% response time is 60 s. The uncertainties of the measurements are claimed to be:

- Calorific Value <  $\pm 0.5\%$  between 25 - 50 MJ/m<sup>3</sup> (7 - 14 kWh/m<sup>3</sup>).
- Density <  $\pm 0.5\%$  between 0.65 - 1.3 kg/m<sup>3</sup>.

### (d) Calorimeters

Two commercially available calorimeter systems calculate the Wobbe Index through controlled combustion of a small sample of gas in a known amount of air. The residual oxygen in the combustion products is related to the Calorific Value of the gas. The output from the device can be used as an additional control signal for air to fuel ratio control of the main burner system.

Thermo ONIX manufacture a high-speed on-line calorimeter called the Fluid Data Flo Cal for measuring the Calorific Value and Wobbe Index of gas. The 90% response time is about 4 minutes and the uncertainty is  $\pm 1.5\%$  in Calorific Value. The Flo Cal has been in operation for about 20 years and it has been used for refinery and petrochemical fuel gas monitoring, steel making, furnace and boiler control, flare gas monitoring, LPG/Air blending and landfill gas monitoring.

Kelma manufacture the Rhadox calorimeter which was originally designed by engineers at Gasunie. The instrument is calibrated with two gases that span the operational range of Calorific Value. The Rhadox 2000 instrument has PTB approval for the measurement of Calorific Value and Relative Density.

## Feedback from Combustion Products

In a similar way to the control of engines through exhaust oxygen level monitoring, several large combustion processes incorporate oxygen monitoring in the flue or chimney stack to feedback information to the air-to-fuel ratio control system.

When boiler burners are manually tuned on a periodic basis, they are typically adjusted to about 3 - 5% excess oxygen which is about 15 - 20% excess air. This is because there are many ambient and atmospheric conditions that can affect oxygen/air supply. For example, colder air is denser and contains more oxygen than warm air; wind speed affects every chimney/flue/stack differently; and barometric pressure further affects draught through the process. Therefore, tuning for excess oxygen/air will ensure that there is enough oxygen available for complete combustion under all conditions.

From an efficiency standpoint, the excess oxygen means there is more air in the combustion stream than there needs to be. That air also contains moisture, and it is heated and then lost up the stack.

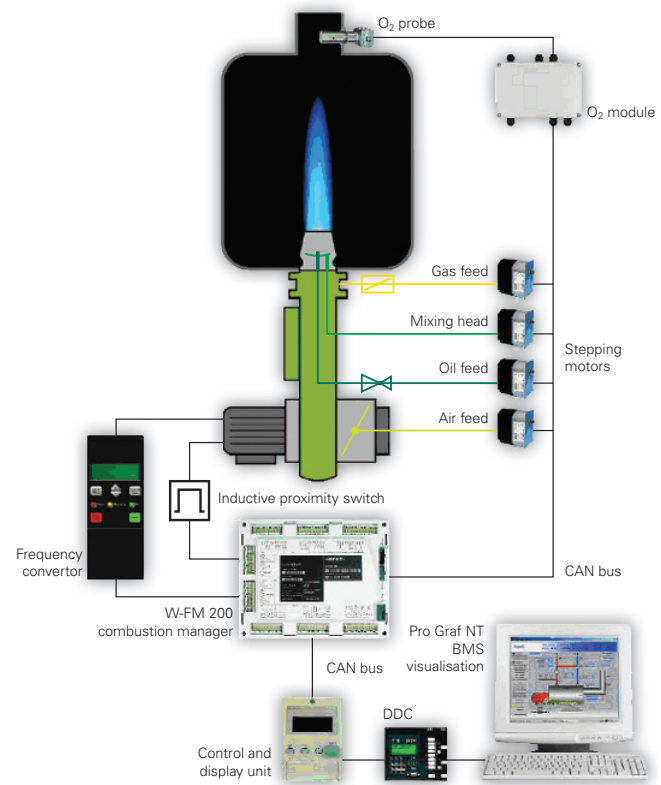
Although it may be possible to monitor and adjust the burner on a daily basis, it is not practical and could potentially be very costly. Automatic oxygen systems continuously monitor the flue gases and adjust the burner air supply. They are generically called 'O<sub>2</sub> Trim Systems'. A schematic layout of an oxygen trim system is shown in Figure 7.22.

Care must be taken with location of the oxygen probe to ensure that it is measuring the flue gas from the process. Combustion plants often has air leakage or "tramp" air (through walls or penetrations into the combustion/process chamber) which increases the oxygen level in the flue gas. But the "tramp" air has not passed through the process and was not part of the controlled air supply hence control system adjustments based on the measured oxygen level may not give the desired result.

Also, some combustion plant processes are too aggressive for the oxygen probe, in particular high temperature glass furnaces which can undermine the operation of the probe and result in incorrect measurements.

With a well-maintained and well-controlled combustion plant, oxygen trim provides a good method of maintaining high efficiency.

An example of an oxygen trim set-up is shown below:



**Figure 7.22 – An Oxygen Trim Set-up.**

One European domestic boiler manufacturer (Weishaupt) has introduced a self-adapting control system based on oxygen levels in the flue gas (called SCOT) which takes the concepts of industrial oxygen trim and applies them to a domestic-scale boiler. Other boiler manufacturers in Europe are investigating similar approaches to enable newer boilers to be more tolerant of changes in gas composition. The designs produced so far are not adapted for large-scale retro-fit into the existing domestic gas appliance market.

### Adaptive Engine Tuning

The IGU has commissioned studies into measures that may be required to enable NGVs to be filled from a range of different filling stations. The wide range of different qualities of natural gas distributed at different filling stations potentially gives rise to an engine management problem, in that for correct timing the engine management system must be recalibrated to fit the potentially new fuel mix in the tanks.

Some manufacturers automatically engage a self-adaptive program immediately after refuelling of the vehicle and via the owner's manual inform the driver that the engine performance during the first minutes after refuelling could be slightly below par. Even if the drivers accept this shortcoming, the compulsory onboard diagnostic systems are less forgiving and are likely to register emissions outside the allowed range. The wide spread of allowed natural gas qualities presents a very large challenge for engine operation to ensure that vehicles comply with legislated emission constraints. An example of the variation in gas quality as represented using Wobbe Index is shown in the following diagram:



**Figure 7.23** – Worldwide Variation in Wobbe Index.

Technology exists to handle the changes in gas quality on engine performance but practical implementation could be both costly and time consuming.

### Gas Turbine Blending or Control of Fuel Properties

Users are often constrained in their options for control of the fuel gas that they use in large gas turbines. Having two or more gas supplies that can be independently controlled and blended in the correct proportions is unusual but does provide some means of overall gas quality control. This concept has been put forward for a combined cycle gas turbine power plant in Asia, where the power station has an existing indigenous gas supply but will be close to a planned LNG import facility. The potential to blend re-gasified LNG with the indigenous supply may enable the gas quality to remain within the specification demanded by the gas turbine manufacturer.

As has already been mentioned gas turbines rely on heated fuel to prevent hydrocarbon dew-point issues and carry-forward of liquid droplets into the combustion chambers. This approach resulted in the use of the Modified Wobbe Index which incorporates an additional term related to the gas temperature. As gas turbine operation is linked to Modified Wobbe Index, one method to account for changes in gas composition is through the degree of pre-heating of the fuel. Higher levels of preheating can be accommodated in a combined cycle plant through extraction of some of the steam from the heat recovery steam generator (HRSG) and exchanging of the heat with the incoming gas fuel. Changes to the pre-heat can be accommodated over a relatively long timescale. There are significant problems trying to control the gas heating for transient gas quality changes.





## Chapter 8

### Conclusions and Strategic Decisions

The purpose of this final section of the BP Gas Interchangeability Guidebook is to provide a strategy which pulls together the elements of previous parts of the Guidebook and applies this information to give a decision process for the reader under a series of hypothetical scenarios. This will highlight the factors related to gas quality, which need to be considered in the early stages of an LNG project and which may influence decisions being made by the various stakeholders.

The purpose of the Guidebook has been to indicate areas of concern which may be raised when new LNG projects are proposed and to present possible solutions which mitigate the concerns through the developments and experience used in previous projects worldwide. As the different priorities are identified, some indication is given of the timescales involved for implementation of the strategy. Examples of the strategic approach are worked through in three assumed scenarios using a company firstly as the LNG producer, then as an LNG trader and finally as the LNG import terminal operator.



## 8.1 Stakeholders in the LNG Chain

- Across an LNG chain, especially in a deregulated market, there are different players (stakeholders) involved in the production, shipping, importation, supply and trading of LNG. They all have different interests and therefore, different issues and concerns. The relationships and issues for the various stakeholders are illustrated in Figure 8.1 and Table 8.6.

## 8.2 Examples of Strategic Approach

- The possible strategic approaches for company personnel involved in various activities are discussed in the following cases:

### Case 1: Company as Producer in Far East/Exporting to Europe

- Production and liquefaction costs are the major elements that determine the profitability of an upstream project. This section explains the importance of gas quality and upstream gas processing requirements.

### Case 2: Company as Trader for LNG from North Africa into UK

- Gas quality in the UK is governed by Gas Safety (Management) Regulations. The imported LNG should be meeting the GS(M)R specifications already or further treatment is required. The factors that need to be taken into account during trading of LNG are detailed here.

### Case 3: Company as Import Terminal Operator Importing Rich Gas from Far East into USA

- Importation of gas/LNG into the USA is controlled by the Federal Energy Regulatory Commission. The gas quality specifications, midstream and downstream quality adjustment options are important here.

### Case 4: Company as a Network Operator / Supplier in Far East

## 8.3 Conclusions

## 8.1 Stakeholders in the LNG Chain

---

**In a deregulated gas/LNG market, there are a number of players (stakeholders) involved across the supply chain. The level of involvement for different stakeholders and potential for objections or support to a new LNG project are dependent on the political position and commercial benefits for each stakeholder.**

---

Table 8.1 shows the various stakeholders who have been identified as having interest in LNG being produced, traded, processed or supplied into a natural gas network.

This guidebook concentrates on the feasibility of potential solutions and less on the costs and commercial viabilities which would need to be considered further. It is also worth noting that the positions of the various stakeholders will be firm and well-established in a mature or developed gas market. However, in new markets there may be more flexibility and opportunity to influence and change stakeholder attitude to LNG importation.

The three major external stakeholders in an LNG project are identified to be the national government (at the project location), government departments/agencies and trade associations.

- National government. The response of national governments to new LNG project proposals is usually driven by the need to secure additional energy supplies and therefore this is most likely to be a positive position.
- Government departments. As Table 8.1 shows, there may be certain government departments such as the Energy Regulator, Health & Safety, Energy Efficiency or Environment agencies who will be looking to protect forecasts or targets in the interest of their constituents. Regional politics may have a greater influence in some countries such as USA and China where State regulations may be more important.
- Trade associations. Stakeholders may also be represented by trade associations (for example industrial end-users) or consumer groups (for example residential end-users). As one body, representing many companies, or a large population, these can provide a powerful lobby.

Table 8.1 provides a brief summary for the issues faced by different stakeholders in the LNG chain under different hypothetical scenarios, together with proposed mitigation. A quick reference guide to the point in this Guidebook where that issue is discussed is also included. The stakeholders' concerns in various company activities as a producer, trader and importer are highlighted using a "traffic light" system in Table 8.2 to Table 8.5. Depending on the role of the company in the project, a high level of priority or interest is represented in red, while the lowest priority is green.

Regulations and contracts are put in place for the activities across the LNG supply chain to ensure regulatory compliance and avoid disputes between commercial partners. A simplified relationship is illustrated in Figure 8.1. Issues which stakeholders need to address, across the LNG supply chain, are summarised in Table 8.6.



Stakeholder	Issues	Mitigation	Guidebook
<b>National Government</b>			
– Energy Supply	Security of supply	Flexibility of supply	Ch4 Ch5
	Market volatility	Long-term contracts and stable supply routes	Ch5
– Energy Regulator	Consumer gas pricing	Minimal processing at importation	Ch7
– Health & Safety Agency	Process/plant safety	Experience and plant safety records	Ch4 Ch7
	Gas network safety	Pipeline network safety record and experience	Ch2 Ch7
	Consumer safety	Interchangeability parameters and test programmes	Ch2
– Environment Agency	Emissions impact	Interchangeability parameters and test results	Ch2 Ch6
	Visual impact	Previous project data and minimal processing	Ch6
– Health & Safety Agency	Liquefaction process	Design of plant/process on capacity & experience	Ch4 Ch5
	Gas specification	Optimise process to required gas quality	Ch4 Ch7
	Markets	Potential for NGL/LPG sales locally	Ch4 Ch5 Ch7
	Standards and legislation	Participation in working groups	3.5
<b>LNG Trader</b>	Market liberalisation	Understanding market deregulation	Ch5
	New markets	Market trends and developing gas markets	Ch5
<b>LNG Shipper</b>	Weathering	Calculations on boil-off during shipment timescales	4.2
	Energy accounting	Working to relevant Standards	Ch3 4.3
	Processing requirements	Options for processing	Ch4 Ch7
	Energy accounting	Working to relevant Standards	Ch3 4.3
<b>LNG Terminal Operator</b>	Boil-off gas	Calculations on boil-off during storage & offloading	Ch4
	Storage	Tank blending	Ch4 7.2
	Pipeline entry specification	Network mixing	Ch2 7.2
<b>Gas Transporter/ Transmission</b>	Pipeline specification	Entry specifications & legislation	Ch3 Ch5
	Blending	Availability of pipeline gas	Ch7
	Zone of LNG influence	Modelling of pipeline gas flows and composition	Ch7
<b>Gas Distributor/ City Gas</b>	Gas quality specification	Regulations & legislation	2.4 Ch3 Ch5
	Grid integrity	Experience from other LNG projects	1.3 Ch7
<b>Gas Supplier</b>	Gas quality specification	Gas interchangeability	Ch1 Ch2 Ch6
<b>End User</b>			
– Industrial	Product quality issues	Interchangeability	1.3 2.2 6.2 6.3 6.5
– Commercial	Heating/cooling services issues	Interchangeability	1.3 2.2 6.2 6.4
– Residential	Safety concerns on combustion	Wobbe Index range	1.3 2.2 6.2 6.3 6.4
– Power Generation/Turbines	Turbine combustion instability	Rate of change of Wobbe Index	1.3 2.2 6.2 6.3
– Natural Gas Vehicles/Engines	Knock resistance	Methane numbers	1.3 2.2 6.4

**Table 8.2** – Stakeholders priorities for the company as a Producer in Far East/Exporting to Europe.

## Case 1: Company as Producer in Far East/Exporting to Europe

Stakeholder	Issues	Mitigation	Guidebook
<b>National Government</b>			
– Energy Supply	<b>Security of supply</b>	Flexibility of supply	Ch4 Ch5
	<b>Market volatility</b>	Long-term contracts and stable supply routes	Ch5
– Energy Regulator	<b>Consumer gas pricing</b>	Minimal processing at importation	Ch7
– Health & Safety Agency	<b>Process/plant safety</b>	Experience and plant safety records	Ch4 Ch7
	<b>Gas network safety</b>	Pipeline network safety record and experience	Ch2 Ch7
	<b>Consumer safety</b>	Interchangeability parameters and test programmes	Ch2
– Environment Agency	<b>Emissions impact</b>	Interchangeability parameters and test results	Ch2 Ch6
	<b>Visual impact</b>	Previous project data and minimal processing	Ch6
– Health & Safety Agency	<b>Liquefaction process</b>	Design of plant/process on capacity & experience	Ch4 Ch5
	<b>Gas specification</b>	Optimise process to required gas quality	Ch4 Ch7
	<b>Markets</b>	Potential for NGL/LPG sales locally	Ch4 Ch5 Ch7
	<b>Standards and legislation</b>	Participation in working groups	3.5
<b>LNG Trader</b>	<b>Market liberalisation</b>	Understanding market deregulation	Ch5
	<b>New markets</b>	Market trends and developing gas markets	Ch5
<b>LNG Shipper</b>	<b>Weathering</b>	Calculations on boil-off during shipment timescales	4.2
	<b>Energy accounting</b>	Working to relevant Standards	Ch3 4.3
<b>LNG Terminal Operator</b>	<b>Processing requirements</b>	Options for processing	Ch4 Ch7
	<b>Energy accounting</b>	Working to relevant Standards	Ch3 4.3
	<b>Boil-off gas</b>	Calculations on boil-off during storage & offloading	Ch4
	<b>Storage</b>	Tank blending	Ch4 7.2
	<b>Pipeline entry specification</b>	Network mixing	Ch2 7.2
<b>Gas Transporter/ Transmission</b>	<b>Pipeline specification</b>	Entry specifications & legislation	Ch3 Ch5
	<b>Blending</b>	Availability of pipeline gas	Ch7
	<b>Zone of LNG influence</b>	Modelling of pipeline gas flows and composition	Ch7
<b>Gas Distributor/ City Gas</b>	<b>Gas quality specification</b>	Regulations & legislation	2.4 Ch3 Ch5
	<b>Grid integrity</b>	Experience from other LNG projects	1.3 Ch7
<b>Gas Supplier</b>	<b>Gas quality specification</b>	Gas interchangeability	Ch1 Ch2 Ch6
<b>End User</b>			
– Industrial	<b>Product quality issues</b>	Interchangeability	1.3 2.2 6.2 6.3 6.5
– Commercial	<b>Heating/cooling services issues</b>	Interchangeability	1.3 2.2 6.2 6.4
– Residential	<b>Safety concerns on combustion</b>	Wobbe Index range	1.3 2.2 6.2 6.3 6.4
– Power Generation/Turbines	<b>Turbine combustion instability</b>	Rate of change of Wobbe Index	1.3 2.2 6.2 6.3
– Natural Gas Vehicles/Engines	<b>Knock resistance</b>	Methane numbers	1.3 2.2 6.4

## Case 2: Company as Trader/LNG from North Africa into UK

Stakeholder	Issues	Mitigation	Guidebook
<b>National Government</b>			
– Energy Supply	<b>Security of supply</b>	Flexibility of supply	Ch4 Ch5
	<b>Market volatility</b>	Long-term contracts and stable supply routes	Ch5
– Energy Regulator	<b>Consumer gas pricing</b>	Minimal processing at importation	Ch7
– Health & Safety Agency	<b>Process/plant safety</b>	Experience and plant safety records	Ch4 Ch7
	<b>Gas network safety</b>	Pipeline network safety record and experience	Ch2 Ch7
	<b>Consumer safety</b>	Interchangeability parameters and test programmes	Ch2
– Environment Agency	<b>Emissions impact</b>	Interchangeability parameters and test results	Ch2 Ch6
	<b>Visual impact</b>	Previous project data and minimal processing	Ch6
– Health & Safety Agency	<b>Liquefaction process</b>	Design of plant/process on capacity & experience	Ch4 Ch5
	<b>Gas specification</b>	Optimise process to required gas quality	Ch4 Ch7
	<b>Markets</b>	Potential for NGL/LPG sales locally	Ch4 Ch5 Ch7
	<b>Standards and legislation</b>	Participation in working groups	3.5
<b>LNG Trader</b>	<b>Market liberalisation</b>	Understanding market deregulation	Ch5
	<b>New markets</b>	Market trends and developing gas markets	Ch5
<b>LNG Shipper</b>	<b>Weathering</b>	Calculations on boil-off during shipment timescales	4.2
	<b>Energy accounting</b>	Working to relevant Standards	Ch3 4.3
<b>LNG Terminal Operator</b>	<b>Processing requirements</b>	Options for processing	Ch4 Ch7
	<b>Energy accounting</b>	Working to relevant Standards	Ch3 4.3
	<b>Boil-off gas</b>	Calculations on boil-off during storage & offloading	Ch4
	<b>Storage</b>	Tank blending	Ch4 7.2
<b>Gas Transporter/ Transmission</b>	<b>Pipeline entry specification</b>	Network mixing	Ch2 7.2
	<b>Pipeline specification</b>	Entry specifications & legislation	Ch3 Ch5
	<b>Blending</b>	Availability of pipeline gas	Ch7
<b>Gas Distributor/ City Gas</b>	<b>Zone of LNG influence</b>	Modelling of pipeline gas flows and composition	Ch7
	<b>Gas quality specification</b>	Regulations & legislation	2.4 Ch3 Ch5
<b>Gas Supplier</b>	<b>Grid integrity</b>	Experience from other LNG projects	1.3 Ch7
	<b>Gas quality specification</b>	Gas interchangeability	Ch1 Ch2 Ch6
<b>End User</b>			
– Industrial	<b>Product quality issues</b>	Interchangeability	1.3 2.2 6.2 6.3 6.5
– Commercial	<b>Heating/cooling services issues</b>	Interchangeability	1.3 2.2 6.2 6.4
– Residential	<b>Safety concerns on combustion</b>	Wobbe Index range	1.3 2.2 6.2 6.3 6.4
– Power Generation/Turbines	<b>Turbine combustion instability</b>	Rate of change of Wobbe Index	1.3 2.2 6.2 6.3
– Natural Gas Vehicles/Engines	<b>Knock resistance</b>	Methane numbers	1.3 2.2 6.4

**Table 8.4** – Stakeholders’ Priorities for the company as an Import Terminal Operator for Rich gas from Far East into USA.

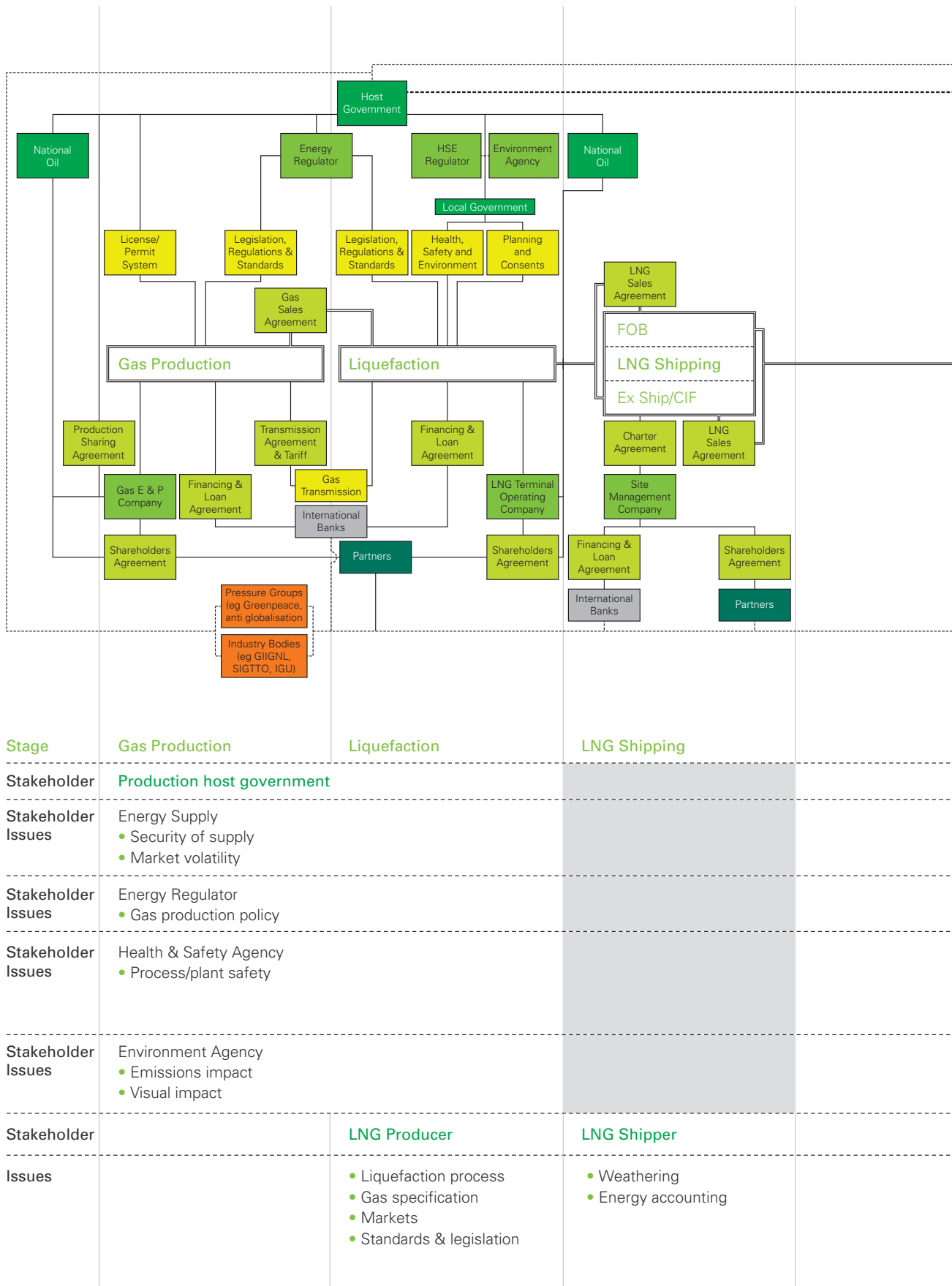
### Case 3: Company as Importation Terminal Operator/Importing Rich Gas from Far East into USA

Stakeholder	Issues	Mitigation	Guidebook
<b>National Government</b>			
– Energy Supply	<b>Security of supply</b>	Flexibility of supply	Ch4 Ch5
	<b>Market volatility</b>	Long-term contracts and stable supply routes	Ch5
– Energy Regulator	<b>Consumer gas pricing</b>	Minimal processing at importation	Ch7
– Health & Safety Agency	<b>Process/plant safety</b>	Experience and plant safety records	Ch4 Ch7
	<b>Gas network safety</b>	Pipeline network safety record and experience	Ch2 Ch7
	<b>Consumer safety</b>	Interchangeability parameters and test programmes	Ch2
– Environment Agency	<b>Emissions impact</b>	Interchangeability parameters and test results	Ch2 Ch6
	<b>Visual impact</b>	Previous project data and minimal processing	Ch6
– Health & Safety Agency	<b>Liquefaction process</b>	Design of plant/process on capacity & experience	Ch4 Ch5
	<b>Gas specification</b>	Optimise process to required gas quality	Ch4 Ch7
	<b>Markets</b>	Potential for NGL/LPG sales locally	Ch4 Ch5 Ch7
	<b>Standards and legislation</b>	Participation in working groups	3.5
<b>LNG Trader</b>	<b>Market liberalisation</b>	Understanding market deregulation	Ch5
	<b>New markets</b>	Market trends and developing gas markets	Ch5
<b>LNG Shipper</b>	<b>Weathering</b>	Calculations on boil-off during shipment timescales	4.2
	<b>Energy accounting</b>	Working to relevant Standards	Ch3 4.3
<b>LNG Terminal Operator</b>	<b>Processing requirements</b>	Options for processing	Ch4 Ch7
	<b>Energy accounting</b>	Working to relevant Standards	Ch3 4.3
	<b>Boil-off gas</b>	Calculations on boil-off during storage & offloading	Ch4
	<b>Storage</b>	Tank blending	Ch4 7.2
	<b>Pipeline entry specification</b>	Network mixing	Ch2 7.2
<b>Gas Transporter/ Transmission</b>	<b>Pipeline specification</b>	Entry specifications & legislation	Ch3 Ch5
	<b>Blending</b>	Availability of pipeline gas	Ch7
	<b>Zone of LNG influence</b>	Modelling of pipeline gas flows and composition	Ch7
<b>Gas Distributor/ City Gas</b>	<b>Gas quality specification</b>	Regulations & legislation	2.4 Ch3 Ch5
	<b>Grid integrity</b>	Experience from other LNG projects	1.3 Ch7
<b>Gas Supplier</b>	<b>Gas quality specification</b>	Gas interchangeability	Ch1 Ch2 Ch6
<b>End User</b>			
– Industrial	<b>Product quality issues</b>	Interchangeability	1.3 2.2 6.2 6.3 6.5
– Commercial	<b>Heating/cooling services issues</b>	Interchangeability	1.3 2.2 6.2 6.4
– Residential	<b>Safety concerns on combustion</b>	Wobbe Index range	1.3 2.2 6.2 6.3 6.4
– Power Generation/Turbines	<b>Turbine combustion instability</b>	Rate of change of Wobbe Index	1.3 2.2 6.2 6.3
– Natural Gas Vehicles/Engines	<b>Knock resistance</b>	Methane numbers	1.3 2.2 6.4

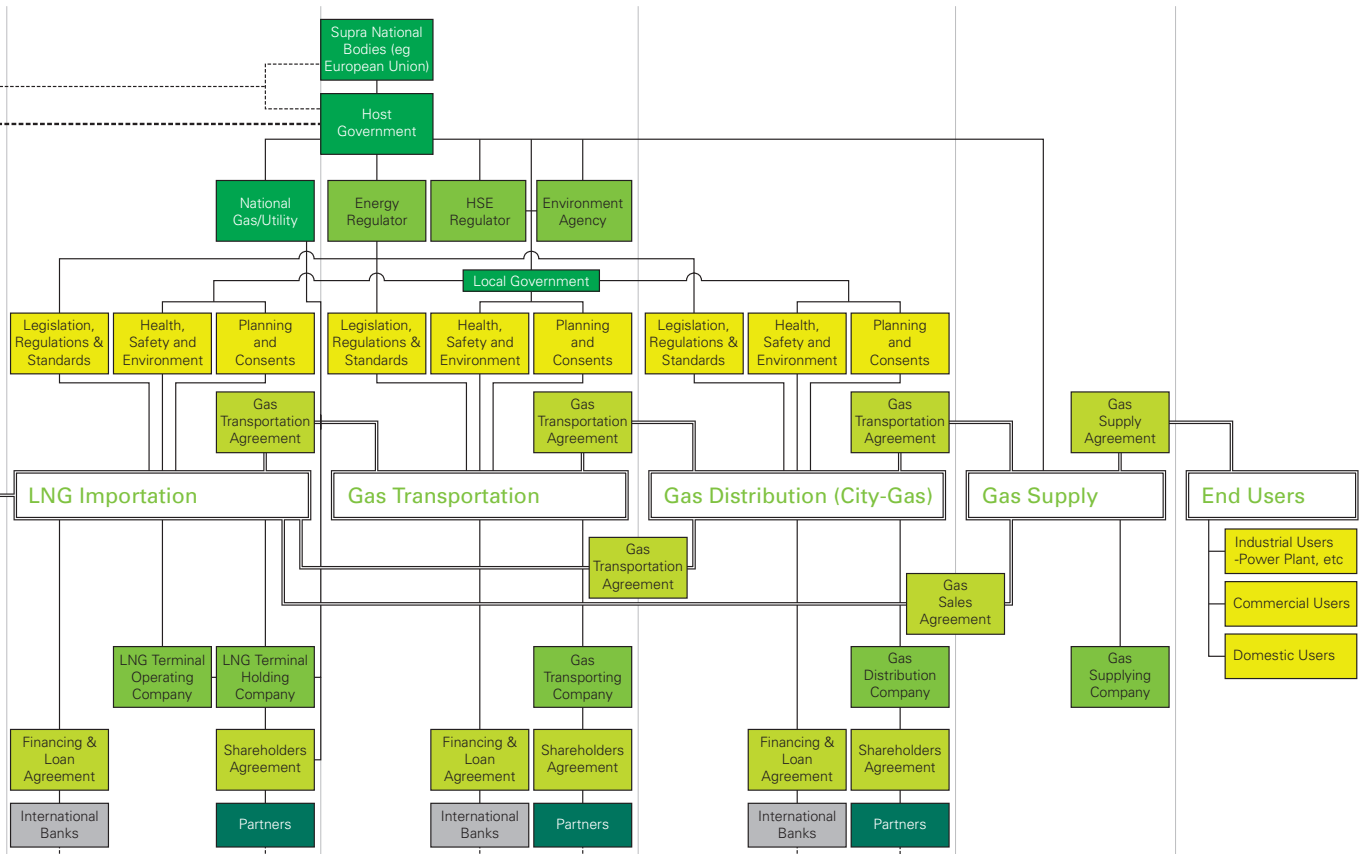
### Case 4: Company as Network Operator/Supplier in Far East

Stakeholder	Issues	Mitigation	Guidebook
<b>National Government</b>			
– Energy Supply	<b>Security of supply</b>	Flexibility of supply	Ch4 Ch5
	<b>Market volatility</b>	Long-term contracts and stable supply routes	Ch5
– Energy Regulator	<b>Consumer gas pricing</b>	Minimal processing at importation	Ch7
– Health & Safety Agency	<b>Process/plant safety</b>	Experience and plant safety records	Ch4 Ch7
	<b>Gas network safety</b>	Pipeline network safety record and experience	Ch2 Ch7
	<b>Consumer safety</b>	Interchangeability parameters and test programmes	Ch2
– Environment Agency	<b>Emissions impact</b>	Interchangeability parameters and test results	Ch2 Ch6
	<b>Visual impact</b>	Previous project data and minimal processing	Ch6
– Health & Safety Agency	<b>Liquefaction process</b>	Design of plant/process on capacity & experience	Ch4 Ch5
	<b>Gas specification</b>	Optimise process to required gas quality	Ch4 Ch7
	<b>Markets</b>	Potential for NGL/LPG sales locally	Ch4 Ch5 Ch7
	<b>Standards and legislation</b>	Participation in working groups	3.5
<b>LNG Trader</b>	<b>Market liberalisation</b>	Understanding market deregulation	Ch5
	<b>New markets</b>	Market trends and developing gas markets	Ch5
<b>LNG Shipper</b>	<b>Weathering</b>	Calculations on boil-off during shipment timescales	4.2
	<b>Energy accounting</b>	Working to relevant Standards	Ch3 4.3
<b>LNG Terminal Operator</b>	<b>Processing requirements</b>	Options for processing	Ch4 Ch7
	<b>Energy accounting</b>	Working to relevant Standards	Ch3 4.3
	<b>Boil-off gas</b>	Calculations on boil-off during storage & offloading	Ch4
	<b>Storage</b>	Tank blending	Ch4 7.2
<b>Gas Transporter/ Transmission</b>	<b>Pipeline entry specification</b>	Network mixing	Ch2 7.2
	<b>Pipeline specification</b>	Entry specifications & legislation	Ch3 Ch5
	<b>Blending</b>	Availability of pipeline gas	Ch7
<b>Gas Distributor/ City Gas</b>	<b>Zone of LNG influence</b>	Modelling of pipeline gas flows and composition	Ch7
	<b>Gas quality specification</b>	Regulations & legislation	2.4 Ch3 Ch5
<b>Gas Supplier</b>	<b>Grid integrity</b>	Experience from other LNG projects	1.3 Ch7
	<b>Gas quality specification</b>	Gas interchangeability	Ch1 Ch2 Ch6
<b>End User</b>			
– Industrial	<b>Product quality issues</b>	Interchangeability	1.3 2.2 6.2 6.3 6.5
– Commercial	<b>Heating/cooling services issues</b>	Interchangeability	1.3 2.2 6.2 6.4
– Residential	<b>Safety concerns on combustion</b>	Wobbe Index range	1.3 2.2 6.2 6.3 6.4
– Power Generation/Turbines	<b>Turbine combustion instability</b>	Rate of change of Wobbe Index	1.3 2.2 6.2 6.3
– Natural Gas Vehicles/Engines	<b>Knock resistance</b>	Methane numbers	1.3 2.2 6.4

**Table 8.6 – Relationship between Stakeholders across LNG Chain.**







LNG Importation      Gas Transportation      Gas Distribution      Gas Supply      End Users

**Importation host government**

Energy Supply  
 • Security of supply  
 • Market volatility

Energy Regulator  
 • Consumer gas pricing

Health & Safety Agency  
 • Process/plant safety  
 • Gas network safety  
 • Consumer safety

Environment Agency  
 • Emissions impact  
 • Visual impact

**LNG Terminal Operator**

- Processing requirements
- Energy accounting
- Boil-off gas
- Storage
- Pipeline entry specification

## 8.2 Examples of Strategic Approach

### Case 1 – Company as Producer in Far East/Exporting to Europe/North America

---

**The initial knowledge requirement by the LNG producer will be an understanding of the gas quality provided at gas source. Knowledge of the potential markets, downstream requirements and economics of processing upstream would determine the gas/LNG quality. Any requirements for removal of impurities will be identified and limited under gas purchasing contracts.**

---

The source gas composition may restrict the financial viability of markets for the gas. For example, a rich LNG may require significant gas processing, including possible inert gas ballasting, for some parts of the European and North American markets. Whereas shipment to Japan may require less processing and hence may look more attractive.

- Gas source composition and variability will be identified in order to design the liquefaction plant capability and capacity requirements.
- Ship loading flexibility and capacity will be linked to long-term contracts gained from the European or North American market.

The options for gas processing and adjustment of Wobbe Index or Calorific Value will depend on the local country market for natural gas liquids (NGLs) or liquefied petroleum gas (LPG) which may be stripped at the liquefaction plant and sold for local distribution.

The European market is changing rapidly as indigenous supplies of natural gas decline and LNG importation becomes more important. The LNG producer must be aware of the political situation in different European countries and the energy mix proposed by the different governments.

The European Commission is encouraging the harmonisation of standards across Europe and it is proposed that this will result in 2010 in a gas quality standard for Europe. Individual countries may have to process gas still to meet their national entry specifications but potentially this means that some European countries will take gas at wider Wobbe and Calorific Value limits than their neighbours.

The producer would identify potential importation terminals and also consider the flexibility for change in market conditions such that potential USA sales or other Atlantic area customers are within economic trading reach.

The timescales for permits, planning consent and contractual, commercial arrangements to be completed for a new liquefaction plant could be 5 to 10 years followed by another 2 - 4 years of construction.

### Case 2 – Company as Trader for LNG from North Africa into UK

---

**As an LNG trader, the strategic decisions are centred on gas cost, market demands and cost of gas processing in the UK. Understanding of gas quality impacts on the downstream market would facilitate commercial negotiations with an import terminal operator and increase confidence in the gas suitability for downstream equipment.**

---

This Guidebook has described the constraints still in place in terms of gas quality specifications in the UK. As a major natural gas consumer in Europe, the UK has one of the smallest ranges of Wobbe allowable in its Gas Safety (Management) Regulations, or GS(M)R. The UK market is therefore attractive in terms of volume but less attractive in the requirement for gas processing and ballasting of LNG imports.

Future harmonised European gas quality standards will improve the potential trading position but the UK government has stated that the GS(M)R limits will not be changed for at least 20 years or more. This is due to the population of old gas appliances in the UK and the fact that a change-out or conversion exercise (costed at £2 - 14 billion) would be far more expensive than continued gas processing at entry terminals (costed at £0.5 billion).

The trader should be more aware of the issues regarding downstream use such as end-user concerns on Wobbe Index limits and the rate of change of gas quality. This information will be required in order to negotiate terms with the importation terminal operator on gas processing requirements and to dispel any fears of downstream equipment owners in terms of gas availability and variability.

Sources of natural gas into the UK market have changed significantly in recent years. Indigenous North Sea gas reserves are declining and the UK is now a net importer of natural gas via new pipeline interconnection and new LNG importation terminals. Energy market liberalisation across Europe could add to price volatility and the LNG trader shipping in to UK would need to understand the options for trading elsewhere in Europe or potentially across the Atlantic.

The timescales for agreeing trading arrangements for LNG shipments into the UK will be similar to those required for the terminal construction period (2 - 4 years).

## 8.3 Conclusions

### Case 3 – Company as Importation Terminal Operator Importing Rich Gas from Far East into USA

**An important factor in any strategic approach for the importation terminal operator in the USA is to meet both Federal and State Regulations on gas tariffs. Options for gas processing and options for gas blending should be considered together with opportunities for medium pressure distribution supply of boil-off gas.**

Planning consents can prove to be lengthy proceedings with State regulators and FERC (Federal Energy Regulatory Commission) hearings requiring testimonies from all parties who may be affected including terminal, transmission, distribution, gas supply and end-user operations. The NGC+ white paper to FERC is being accepted as a start point for gas tariff specifications on gas quality. This sets Wobbe Index limits at  $\pm 4\%$  around the historical average Wobbe Index level, with a maximum Wobbe Index of 1,400 Btu/cf and High Heating Value capped at 1,110 Btu/cf. Higher hydrocarbons (C<sub>4</sub>+) at 1.5 mol% and total inerts at 4 mol% are also capped.

Downstream users will have concerns on gas quality variation particularly gas turbines for power generation plant which may be sensitive to rate of change of Wobbe Index. Network modelling can be used to illustrate blending and mixing of vaporised LNG gas within networks.

This Gas Interchangeability Guidebook has been developed to provide a range of readers with the issues and mitigation actions surrounding gas quality for the increasing worldwide trading of LNG and natural gas.

Wherever possible, real case studies have been used to illustrate how problems have been identified and overcome through technical or commercial solutions.

The strategic approach taken by a company in addressing a new LNG project will be steered by the role being adopted by the company as LNG producer, trader or importer. The Guidebook shows how issues of gas quality and gas interchangeability can alter priorities depending on the company role and the markets being targeted for business development.



## Glossary of Terms

ACER	Agency for Cooperation of Energy Regulators
AGA	American Gas Association
ASTM	American Society for Testing and Materials
API	American Petroleum Institute
APX	C3MR with cold-end nitrogen expander cycle process
(m)bar(a)	(milli)bar absolute
(m)Bar(g)	(milli)bar gauge
BOG	Boil-off gas
BSI	British Standards Institute
btu	British Thermal Units
BV	Burning velocity (flame speed)
BWRS	Benedict-Webb-Ruben-Starling
CH <sub>4</sub>	Methane
C <sub>2</sub> or C <sub>2</sub> H <sub>6</sub>	Ethane
C <sub>3</sub> or C <sub>3</sub> H <sub>8</sub>	Propane
C <sub>4</sub> or C <sub>4</sub> H <sub>10</sub>	Butanes (iC <sub>4</sub> - iso, nC <sub>4</sub> - normal butane)
C <sub>5</sub> or C <sub>5</sub> H <sub>12</sub>	Pentanes (iC <sub>5</sub> - iso, nC <sub>5</sub> - normal, neoC <sub>5</sub> - neo-pentane)
C6+	Hydrocarbons heavier than pentane
C3MR	Propane and mixed refrigerant
CAPEX	Capital expenditure
CARB	California Air Resources Board
CBP	Common Business Practice
CCGT	Combined cycle gas turbine
CEC	California Energy Commission
CEER	Council of European Energy Regulators
CEN	European Committee for Standardisation
cf	Cubic feet
CFD	Computational fluid dynamics
CHDP	Cricondentherm Hydrocarbon Dew Point
CIF	Cost insurance freight
CNG	Compressed natural gas
CNOOC	China National Offshore Oil Corporation
CO	Carbon monoxide
CO <sub>2</sub>	Carbon dioxide
COS	Carbonyl sulphide
CPUC	California Public Utilities Commissions
CRE	French Energy Regulator
CTMS	custody transfer measurement system
CV	Calorific Value
DEPA	Public Gas Corporation of Greece
DG Tren	European Commission's Directorate for Energy and Transport

DLE	Dry low emission
DLN	Dry low NOx
DMR	Double mixed-refrigerant
DOE	Department of Energy (US)
DTI	Department of Trade and Industry (UK)
EASEE-gas	European Association for the Streamlining of Energy Exchange
EGR	Exhaust gas recirculation
EGO	Exhaust gas oxygen
EM	Ethylmercaptan
EBRV	Energy Bridge Re-gasification Vessel
EOS	Equation of state
EPA	Environmental Protection Agency
EU	European Union
FERC	Federal Energy Regulatory Commission
FSRU	Floating, storage and re-gasification unit
FOB	Free-on-board
FPD	Flame photometric detector
G[00]	Appliance test gases as defined in BS EN 437
GAD	Gas Appliance Directive
GAMA	Gas Appliance Manufacturers Association
GBS	Gravity base structure
GC	Gas chromatograph
GCV	Gross Calorific Value
GdF	Gaz de France
GE	General Electric
GIIGNL	Groupe International des Importateurs de Gaz Naturel Liquéfié
GPA	Gas Processors Association
GS(M)R	Gas Safety (Management) Regulations
GT	Gas turbine
GTI	Gas Technology Institute
GTT	Gas Transport & Technigaz
GUM	Guide to Expression of Uncertainty in Measurement
GWh	Gigawatt hour (equivalent to 1x10 <sup>9</sup> watt hour)
H <sub>2</sub>	Hydrogen
H <sub>2</sub> O	Water
H <sub>2</sub> S	Hydrogen sulphide
HC	Hydrocarbons
H/C	Hydrogen/carbon ratio
HHV	Higher Heating Value
Hg	Mercury
HSE	Health and Safety Executive

ICF	Incomplete Combustion Factor	OEM	Original equipment manufacturer
IGU	International Gas Union	ON	Octane number
ISO	International Organisation for Standardisation	ORV	Open rack vaporiser
KOGAS	Korean Gas Corporation	PAHs	Poly-aromatic hydrocarbons
kPa	Kilo-Pascal	PE	Polyethylene
kWh	Kilowatt hour (equivalent to $1 \times 10^3$ watt hour)	PM	Particulate matter
LDC	Local distribution companies	PN	Propane- nitrogen Number
LDZ	Local distribution zone	ppm(v)	Parts per million (volume)
LEL	Lower explosive limit	PR	Peng-Robinson
LHV	Lower Heating Value	PSA	Pressure swing adsorption
LI	Lift index	PSRK	Predictive Soave-Redlich-Kwong
LNG	Liquefied natural gas	Q	Energy
LPG	Liquefied petroleum gas	RD	Relative Density
nm <sup>3</sup>	Normal cubic metres	RV	Re-gasification vessel
MARAD	U.S. Maritime Administration	RMS	Root mean squared
Marcogaz	Technical Association of the European Natural Gas Industry	scm/sm <sup>3</sup>	Standard cubic metres
mg	(Milli)gram	scf	Standard cubic feet
MJ	Mega Joules (equivalent to $1 \times 10^6$ Joules)	SCR	Selective Catalytic Reduction
MN	Methane Number	SCV	Submerged combustion (fired) vaporiser
MNR	Methane Number requirement	SG	Specific Gravity
MON	Motor Octane Number	SI	Sooting Index
mtpa	Million tonnes per annum	SIGTTO	Society of International Gas Tanker & Terminal Operators Ltd
MW	Molecular weight	SNG	Synthetic natural gas
MWI	Modified Wobbe Index	SOS	Speed of sound
N <sub>2</sub>	Nitrogen	SOx	Oxides of Sulfur
NCV	Net Calorific Value	SPB	Self-supporting Prismatic-shape
NETL	National Energy Technology Laboratory	SRK	Soave-Redlich-Kwong
NG	Natural gas	T	Temperature
NGA	Natural gas analyzer	TBM	Tertiary butylmercaptan
NGC	Natural Gas Council	TCD	Thermal conductivity detector
NGL	Natural gas liquids	THC	Total hydrocarbons
NGV	Natural gas vehicles	THT	Tetrahydrothiophene
Ni	Nickel	TPA	Third party access
NIST	National Institute of Standards and Technology	UAE	United Arab Emirates
NO	Nitric oxide	µg	Microgram (equivalent to $1 \times 10^{-6}$ gram)
NO <sub>2</sub>	Nitrogen dioxide	UHC	Unburned hydrocarbons
NOx	Oxides of Nitrogen	UKCS	United Kingdom continental shelf
NTS	National Transmission System (UK)	USCG	United States Coast Guard
NWS	North West Shelf, Australia	V	Volume
NZS	New Zealand Standard	v/v	Volume of gas per volume of storage
O <sub>2</sub>	Oxygen	VOC	Volatile organic compounds
O&M	Operation and maintenance	WI	Wobbe Index
		WN	Wobbe Number

# Energy Conversion Table

			Watt hours				Therms			Joules	
			From								
			kWh	MWh	GWh	TWh	th	mmbtu	Mth	kJ	GJ
<b>Kilowatt hours</b>	kWh	1		0.001	0.000001	1E-09	0.03412	0.003412	3.412E-08	3600	0.0036
<b>Megawatt hours</b>	MWh	1	1000		0.001	0.000001	34.12	3.412	0.00003412	3600000	3.6
<b>Gigawatt hours</b>	GWh	1	1000000	1000		0.001	34120	3412	0.03412	3.6E+09	3600
<b>Terawatt hours</b>	TWh	1	1E+09	1000000	1000		34120000	3412000	34.12	3.6E+12	3600000
<b>Therms</b>	th	1	29.3071	0.029307	2.93E-05	2.93E-08		0.1	0.000001	105506	0.105506
<b>Decatherms</b>	mmbtu	1	293.071	0.293071	0.000293	2.93E-07	10		0.00001	1055060	1.05506
<b>Million therms</b>	Mth	1	29307100	29307.1	29.3071	0.029307	1000000	100000		1.06E+11	105506
<b>Kilojoules</b>	kJ	1	0.000278	2.78E-07	2.78E-10	2.78E-13	9.478E-06	9.48E-07	9.478E-12		0.000001
<b>Gigajoules</b>	GJ	1	2778	0.2778	0.000278	2.78E-07	9.478	0.9478	9.478E-09	1000000	
<b>Kilocalories</b>	kcal	1	0.001163	1.16E-06	1.16E-09	1.16E-12	3.968E-05	3.97E-06	3.968E-11	4.1868	4.19E-06
<b>Gigacalories</b>	Gcal	1	1163	1.163	0.001163	1.16E-06	39.68	3.968	0.00003968	4186800	4.1868
<b>Cubic feet (natural gas)</b>	ft <sup>3</sup>	1	0.3	0.0003	3E-07	3E-10	0.0104	0.00104	1.04E-08	109726	0.001097
<b>Thousand cubic feet</b>	thou.ft <sup>3</sup>	1	300	0.3	0.0003	3E-07	10.4	1.04	0.0000104	1097260	1.09726
<b>Million cubic feet</b>	m.ft <sup>3</sup>	1	300000	300	0.3	0.0003	10400	1040	0.0104	1.1E+09	109726
<b>Billion cubic feet</b>	bcf	1	3E+08	300000	300	0.3	10400000	1040000	10.4	1.1E+12	1097260
<b>Trillion cubic feet</b>	tcf	1	3E+11	3E+08	300000	300	1.04E+10	1.04E+09	10400	1.1E+15	1.1E+09
<b>Cubic metres (natural gas)</b>	m <sup>3</sup>	1	11	0.011	0.000011	1.1E-08	0.367	0.0367	3.67E-07	38722	0.038722
<b>Thousand cubic metres</b>	thou. m <sup>3</sup>	1	11000	11	0.011	0.000011	367	36.7	0.000367	38722000	38.722
<b>Million cubic metres</b>	mcm	1	11000000	11000	11	0.011	367000	36700	0.367	3.87E+10	38722
<b>Mbillion cubic metres</b>	bcm	1	1.1E+10	11000000	11000	11	3.67E+08	36700000	367	3.87E+13	38722000
<b>Tonnes LNG</b>	tonne	1	14000	14	0.014	0.000014	520	52	0.00052	55000000	55

Calories		Cubic feet of natural gas					Cubic metres of natural gas				Tonnes of LNG
kcal	Gcal	ft <sup>3</sup>	thou.ft <sup>3</sup>	m.ft <sup>3</sup>	bcf	tcf	m <sup>3</sup>	thou.m <sup>3</sup>	mcm	bcm	tonne
859.845	0.00086	3.3	0.0033	3.3E-06	3.3E-09	3.3E-12	0.093	0.000093	9.3E-08	9.3E-11	0.00066
859845	0.859845	3300	3.3	0.0033	3.3E-06	3.3E-09	93	0.093	0.000093	9.3E-08	0.066
8.6E+08	859.845	3300000	3300	3.3	0.0033	3.3E-06	93000	93	0.093	0.000093	66
8.6E+11	859845	3.3E+09	3300000	3300	3.3	0.0033	93000000	93000	93	0.093	66000
25200	0.0252	96.2	0.0962	9.62E-05	9.62E-08	9.62E-11	2.72	0.00272	2.72E-06	2.72E-09	0.0019
252000	0.252	962	0.962	0.000962	9.62E-07	9.62E-10	272	0.0272	2.72E-05	2.72E-08	0.019
2.52E+10	25200	96200000	96200	96.2	0.0962	9.62E-05	2720000	2720	2.72	0.00272	1900
0.2388	2.39E-07	0.0091	9.1E-06	9.1E-09	9.1E-12	9.1E-15	0.000026	2.6E-08	2.6E-11	2.6E-14	0.000000018
238800	0.2388	9100	9.1	0.0091	9.1E-06	9.1E-09	26	0.026	0.000026	2.6E-08	0.018
	0.000001	0.0038	3.8E-06	3.8E-09	3.8E-12	3.8E-15	0.00011	1.1E-07	1.1E-10	1.1E-13	0.000000076
1000000		3800	3.8	0.0038	3.8E-06	3.8E-09	110	0.11	0.00011	1.1E-07	0.076
262	0.000262		0.001	0.000001	1E-09	1E-12	0.02834	2.83E-05	2.83E-08	2.83E-11	0.00002
262000	0.262	1000		0.001	0.000001	1E-09	28.34	0.02834	2.83E-05	2.83E-08	0.02
2.62E+08	262	1000000	1000		0.001	0.000001	28340	28.34	0.02834	2.83E-05	20
2.62E+11	262000	1E+09	1000000	1000		0.001	28340000	28340	28.34	0.02834	20000
2.62E+14	2.62E+08	1E+12	1E+09	1000000	1000		2.83E+10	28340000	28340	28.34	20000000
9249	0.009249	35.29	0.03529	3.53E-05	3.53E-08	3.53E-11		0.001	0.000001	1E-09	0.00071
9249000	9.249	35290	35.29	0.03529	3.53E-05	3.53E-08	1000		0.001	0.000001	0.71
9.25E+09	9249	35290000	35290	35.29	0.03529	3.53E-05	1000000	1000		0.001	710
9.25E+12	9249000	3.53E+10	35290000	35290	35.29	0.03529	1E+09	1000000	1000		710000
13000000	13	52000	52	0.052	0.000052	5.2E-08	1400	1.4	0.0014	1.4E-06	

# Definitions

## (a) Gas Properties

### A.G.A Index Method

Prediction method of interchangeability in which measured appliance characteristics are used to define relevant gas parameters, based on gas composition.

### Calorific Value – superior or gross (also Higher Heating Value)

The amount of heat which would be released by the complete combustion in air of a specified quantity of gas, in such a way that the pressure at which the reaction takes place remains constant, and all the products of combustion are returned to the same specified temperature as that of the reactants, all of these products being in the gaseous state except for water formed by combustion, which is condensed to the liquid state.

### Calorific Value – inferior or net (also Lower Heating Value)

The amount of heat which would be released by the complete combustion in air of a specified quantity of gas, in such a way that the pressure at which the reaction takes place remains constant, and all the products of combustion are returned to the same specified temperature as that of the reactants, all of these products being in the gaseous state.

### Combustion reference conditions

Specified temperature and pressure at which the fuel is notionally burned.

### Compression factor, Z

The actual (real) volume of a given mass of gas at a specified pressure and temperature divided by its volume, under the same conditions, as calculated from the ideal gas law.

### Cricondentherm

The highest temperature at which two phases can co-exist. The cricondentherm temperature is the highest dew point temperature seen on a liquid-vapour curve for a specific gas composition over a range of pressure. The cricondentherm is calculated by obtaining an extended gas analysis and then inputting the analysis data into a process simulation software package.

### Density, d

The mass of a gas sample divided by its volume at specified conditions of pressure and temperature.

### Dew point

See hydrocarbon dew point.

### Dry natural gas

Gas which does not contain water vapour at a mole fraction greater than 0.00005.

### Flash back

The tendency for the flame to contract towards the port and for the combustion to take place within the burner.

### Hydrocarbon dew point

The temperature above which no condensation of hydrocarbon occurs at a specific pressure.

### Ideal gas and real gas

An ideal gas is one which obeys the ideal gas law:

$$p \cdot V_m = R \cdot T$$

where:  $p$  = absolute pressure  
 $T$  = thermodynamic temperature  
 $V_m$  = the volume per mole of gas  
 $R$  = molar gas constant

However no real gas obeys this law. For real gases, the ideal gas law must be rewritten as:

$$p \cdot V_m = Z(T,p) \cdot R \cdot T$$

where:  $Z(T,p)$  is a variable, often close to unity, and is known as the compression factor.

### Incomplete Combustion Factor, ICF

Defined as:

$$(WN - 50.73 + 0.03PN) / 1.56$$

where: PN is the sum of the percentages by volume of propane and nitrogen in the equivalent mixture.

### Interchangeability

A measure of the degree to which the combustion characteristics of one gas resemble those of another. Two gases are said to be interchangeable if one may be substituted by the other without affecting the satisfactory operation of gas burning appliances or equipment.

### Lifting

Burning surface expands to the point where the burning ceases at the port and burns above it.



### **Lower flammability limit, LFL**

The concentration of flammable gas or vapour in air, below which the gas atmosphere is not explosive.

### **Metering reference conditions**

Specified temperature and pressure at which the volume of fuel to be burned is notionally determined.

### **Methane Number, MN**

Expresses the volume percentage of methane in a methane/hydrogen mixture which, in a test engine under standard conditions, has the same tendency to knock as the fuel gas to be examined.

### **Relative Density (Specific Gravity), RD (SG)**

The density of a gas divided by the density of dry air of standard composition at the same specified conditions of pressure and temperature.

### **Sooting Index, SI**

A measure of the sooting propensity of a gas obtained by determining the volume rate of flow of air required to prevent soot-tailing of the flame of the gas in a standard sooting test burner.

Defined as:

$$0.896 \tan^{-1}(0.0255C_3H_8 - 0.0233N_2 + 0.617)$$

### **Standard reference conditions**

Standard conditions of temperature, pressure and compressibility, to which gas is converted to account for the measurement conditions of those values.

### **Water dewpoint**

The temperature above which no condensation of water occurs at a specific pressure.

### **Weaver Index method**

Method for predicting interchangeability. Incorporates use of flame speed into six indices that define interchangeability of a gas.

### **Wobbe Index (Wobbe Number), WI (WN)**

The superior calorific value on a volumetric basis at specified reference conditions, divided by the square root of the relative density at the same specified combustion and metering reference conditions.

### **Yellow tipping**

Incomplete combustion where excess hydrocarbons could, but not always, result in unacceptable levels of carbon monoxide. May result in soot deposition and a continuing deterioration of combustion.

## **(b) Combustion, Gas Properties and Grouping**

### **Combustion characteristics**

Properties of a gas that influence the behaviour of the flame when the gas is burnt.

#### **Flame speed**

The rate of linear propagation of flame through a gas-air mixture.

#### **Flame-speed factor (Burning velocity), S (BV)**

The burning velocity of a stoichiometric mixture of gas and air expressed as a percentage of the burning velocity of the same mixture of hydrogen and air.

#### **Family of gases**

A range of gases characterized by having a Wobbe Index within specified limits.

#### **First family gas**

Gas of Wobbe Index 24.4 MJ/m<sup>3</sup> to 28.8 MJ/m<sup>3</sup> under standard conditions.

#### **Second family gas**

Gas of Wobbe Index 48.2 MJ/m<sup>3</sup> to 53.2 MJ/m<sup>3</sup> under standard conditions.

#### **Third family gas**

Gas of Wobbe Index 72.6 MJ/m<sup>3</sup> to 87.8 MJ/m<sup>3</sup> under standard conditions.

#### **Gas group A**

Subdivision of a family of gases.

## (c) Flame Phenomena

### Yellow tipping

The appearance of a yellow colour at the top part of the periphery of a flame.

### Flame-lift lifting

Separation of a flame from a burner port, whilst continuing to burn with its base some distance from the port.

### Flame blow-off (flame lift-off)

Separation of a flame from a burner port, resulting in extinction.

### Light-back (flash-back)

Transfer of combustion from a burner port to a point upstream in the gas/air flow.

- a) Direct light-back – light-back through the burner itself.
- b) Indirect light-back (Roll over) – light-back by a flame not passing through the burner itself.

### Air-gas ratio

The ratio of the volume of primary air to the volume of gas in a mixture.

### Theoretical air requirement (stoichiometric air)

The calculated volume of air required for complete combustion of unit volume of gas.

### Stoichiometric mixture (stoichiometric ratio)

A mixture of gas and air in the proportions determined by the theoretical air requirement.

### Excess air

Air in excess of the theoretical requirement, (stoichiometric requirement) for complete combustion, expressed as a percentage.

## (d) Burners

### Burner

The complete unit on which, or in certain cases, in which, a flame is maintained.

### Dual fuel burner (alternative fuel burner)

A burner system that can operate on gas or another fuel.

### Automatic burner

A burner system operated by a fully or semi-automatic control system.

### Flame detector

That part of the flame-failure device that is responsive to flame properties and signals the presence of flame.

## (e) Domestic and Commercial Utilisation

### Gas appliance

An appliance where gas is consumed under control.

### Appliance category

A classification of appliances according to the gas or gases that they are designed to burn.

### Appliance type

A classification of appliances according to the method of disposal of combustion products.

## (f) Industrial Utilisation

### Direct heating

A method of heating furnaces and ovens in which the hot products of combustion come into contact with the stock, (material treated in a furnace or oven).

### Indirect heating

A method of heating furnaces and ovens in which the hot products of combustion do not come into contact with the stock.

### Preheater

A device in which air and/or gas are heated before entering a burner or combustion chamber.

Direct-fired furnace (open flame furnace, in-flame furnace, oven furnace).

A furnace in which stock is heated in a chamber through which flames and combustion products flow.

### Regenerative furnace

A gas-fired furnace in which air required for combustion is preheated by a regenerator. (An apparatus for effecting the transference of heat from one gas to another).





BP Gas Marketing Ltd.  
Registered office: Chertsey Road,  
Sunbury on Thames, TW16 7BP  
UK

Registered in England and Wales,  
number 908982.

[www.bp.com](http://www.bp.com)



International Gas Union  
c/o Statoil ASA  
0246 Oslo  
Norway

Tel: +47 5199 0000  
Fax: +47 2253 6318  
email: [secrigu@statoil.com](mailto:secrigu@statoil.com)

[www.igu.org](http://www.igu.org)



**GL Noble Denton**

GL Industrial Services UK Ltd.  
Holywell Park, Ashby Road  
Loughborough  
Leicestershire  
LE11 3GR

Tel: +44 (0)1509 282000  
Fax: +44 (0)1509 283131

[www.glgroup.com](http://www.glgroup.com)